

SCIENCE LIBRARY

QH  
201  
.R8

[www.libtool.com.cn](http://www.libtool.com.cn)

[www.libtool.com.cn](http://www.libtool.com.cn)

THE MONTHLY  
MICROSCOPICAL JOURNAL:

[www.libtool.com.cn](http://www.libtool.com.cn)

34808

TRANSACTIONS

OF THE

ROYAL MICROSCOPICAL SOCIETY,

AND

RECORD OF HISTOLOGICAL RESEARCH

AT HOME AND ABROAD.

EDITED BY

HENRY LAWSON, M.D., M.R.C.P., F.R.M.S.,

*Assistant Physician to, and Lecturer on Physiology in, St. Mary's Hospital.*

VOLUME XV.



LONDON:

HARDWICKE AND BOGUE, 192, PICCADILLY, W.

MDCCLXXVI.



[www.libtool.com.cn](http://www.libtool.com.cn)

[www.libtool.com.cn](http://www.libtool.com.cn)



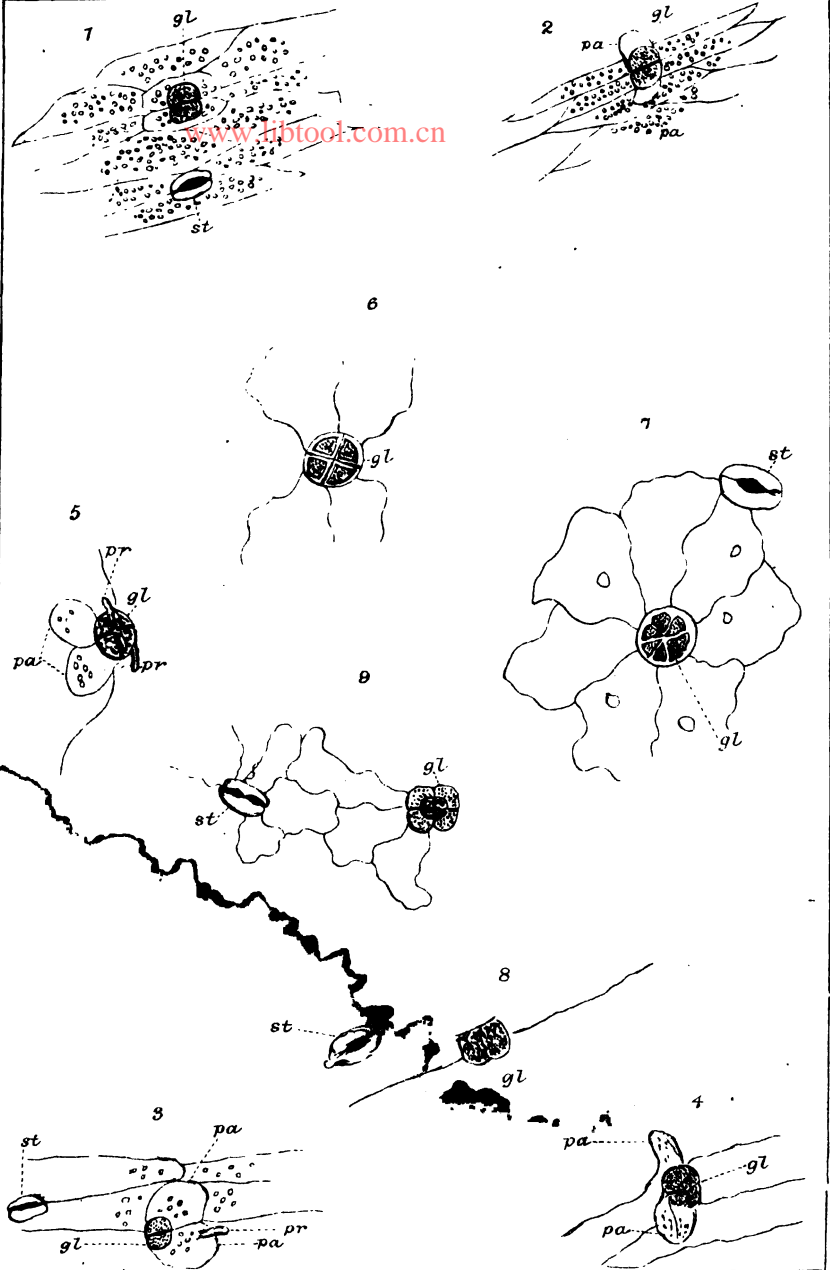

THE  
MONTHLY MICROSCOPICAL JOURNAL.

JANUARY 1, 1876.

I.—*The Absorptive Glands of Carnivorous Plants.*

By ALFRED W. BENNETT, M.A., B.Sc., F.L.S., Lecturer on Botany  
at St. Thomas's Hospital.

(Read before the ROYAL MICROSCOPICAL SOCIETY, December 1, 1875.)

PLATE CXXVI.

THOSE plants which possess the peculiar power of absorbing and digesting nitrogenous substances presented to their leaves, have from time to time engaged the attention of vegetable physiologists. Among the more important papers on the subject may be mentioned those by Grönland and Trécul, in the 'Annales des Sciences Naturelles' for 1855; Nitschke, in the 'Botanische Zeitung' for 1860-61; Warming, in the Proceedings of the 'Société d'Histoire Naturelle de Copenhague' for 1873; and, above all, Darwin's work on Insectivorous Plants, published during the present year. These publications deal chiefly with the insectivorous plants belonging to the genera *Drosera*, *Pinguicula*, *Dionæa*, and *Utricularia*; the "pitcher-plants," *Nepenthes*, *Sarracenia*, *Darlingtonia*, and *Cephalotus*, not having at present received so large a share of attention. As might naturally be expected at first, observation has been up to the present time chiefly directed to the remarkable phenomena connected with the capture and apparent digestion of the living animals which in the natural state are chiefly devoured by these plants; while but little investigation has been applied to the discovery of internal organs by the aid of which absorption is effected; and the assumed absence of any such organs has indeed been brought forward as an argument

EXPLANATION OF PLATE CXXVI.

- FIGS. 1-5.—*Drosera rotundifolia*; *gl*, absorptive gland in various stages of development; *pa*, cellular papillæ; *pr*, processes from papillæ; *st*, stoma.
- „ 6-8.—*Pinguicula vulgaris*; *gl*, absorptive gland; *st*, stoma. Fig. 8 represents a lateral view of a gland projecting slightly above the surface.
- FIG. 9.—*Callitriche verna*; *gl*, absorptive gland; *st*, stoma.

All from nature, and  $\times 250$  diam.

against the possibility of absorption by the leaves. In the case of *Dionæa*, Darwin gives a very brief description of minute glands of a reddish-purple colour which cover the upper side of the leaf, and which he states to have the power of absorption. But in order to find an adequate description of these bodies we must go back nearly thirty years, when Dr. Lindley gave accurate descriptions and figures of them in his 'Ladies' Botany,' published in 1834, and, in the following words, showed a wonderful insight into their probable function:—"From the cuticle of the upper surface of the leaf of *Dionæa* there spring at short intervals little red glands, which grow from minute green oval spaces, composed of two parallel green cells and resembling stomates. They are firm fleshy bodies resembling little convex buttons, and are composed of cells arranged in a circular manner round an axis consisting of two such cells stationed one on the top of the other. I presume that these glands are analogous to the curious hairs of Sundew, although we do not see that they are possessed of any irritability; but in the Sundew they arise from a general expansion of the cuticle and not from spurious stomates. We moreover find upon the surface a prodigious number of red glands, so minute as to be individually invisible to the naked eye, and giving a red tinge to the leaf. Such glands are found nowhere except upon the upper surface of the leaf in the neighbourhood of the delicate seat of irritability. It is not improbable that these glands are either in some way connected with the irritability, although it is not they through which the shock is first communicated to the leaf, or, as Mr. Curtis supposes, are intended to absorb the nutriment afforded to the leaf by the decay of the insects entrapped in it." Similar bodies are also known to exist in *Nepenthes*; and were likewise described by Dr. Lindley, in his 'Introduction to Botany,' edition 1848, as stomates of a peculiar construction in contact with an internal deep brownish-red gland.

My own observations have been entirely confined to the two most readily obtainable of our English carnivorous plants, *Drosera rotundifolia* and *Pinguicula vulgaris*; having paid considerable attention to the structure of the leaves in these two species during my summer holidays for the last three years. In the summer of 1873, while staying in Westmoreland, I first observed and drew certain bodies imbedded in the leaf of *Drosera* which it struck me must be connected with the processes of absorption and digestion, although I could find no record of them by any previous observer. Hearing shortly afterwards that Mr. Darwin was likely soon to bring before the public his store of long-accumulating investigations on these plants, I refrained from publishing my observations. When, however, Darwin's 'Insectivorous Plants' came out, in the spring of 1875, I found no record of the existence of these bodies, notwithstanding the otherwise full and accurate description of the structure

of the leaves in both genera.\* I therefore sent to the 'Popular Science Review' for October in that year, a brief and somewhat inadequate description and figure, which I now propose to give somewhat more in detail, in the hope of throwing some additional light on the processes with which they are apparently connected.

If a careful section is made of the leaf of *Drosera rotundifolia*, there will be found a number of bodies which might at first sight be easily mistaken for stomata, but which are of essentially different structure. In Fig. 1, Pl. XXVI., one of these bodies is represented at *gl*. They are, in their first origin, not superficial, but appear to arise immediately beneath the cuticle chiefly, or perhaps exclusively of the upper surface; in one case I found one imbedded in the tissue immediately beneath a "tentacle" or glandular filament. They consist of two nearly hemispherical cells, filled with a yellowish-brown apparently protoplasmic substance, and form together a nearly spherical body, of which the longest diameter is about  $\cdot 00075$  ( $\frac{3}{4000}$ ) inch. They are more nearly circular and somewhat smaller than the stomata, one of which (*st*) is shown in the drawing. In each of the hemispheres is a darker nucleus-like spot, and each is surrounded by a thin-walled cell containing chlorophyll-grains, much smaller than the ordinary cells of the mesophyll of the leaf, and which seems subsequently to disappear. From these hemispherical bodies are developed two papillæ, successive stages of which are shown by *pa* in Figs. 2-5, with thin transparent walls, and containing grains of chlorophyll. These papillæ sometimes rise above the surface of the leaf or of the filaments of the "tentacles." The hairs or papillæ which result from these glands have been described and figured by Meyen,† Trécul,‡ and Nitschke,§ and are referred to in Darwin's work, p. 8; but their origin from the glands does not appear to have been observed, and they are described as being entirely of an epidermal nature. In the gland drawn in Fig. 5, an indication is apparent of a quadripartite division; and there are also a couple of minute processes (*pr*), one from each hemisphere, which I have also observed in other instances springing either from the glands themselves or the cellular papillæ; one such process is again represented in Fig. 4. To the bodies now described I gave, in the article already referred to,|| the provisional name of "ganglia," which term however I propose now to replace by "absorptive glands," in allusion to their supposed function, and in order to distinguish them from the secretive "glands," as they are termed by Darwin, which form the apices of the "tentacles."

\* I have since had the pleasure of showing my preparations to Mr. Darwin who tells me that these bodies have not hitherto engaged his attention.

† 'Die Secretions-Organer der Pflanzen,' 1837.

‡ 'Annales des Sciences Naturelles, Botanique,' 4 series, vol. iii. p. 308.

§ 'Botanische Zeitung,' 1861, p. 235.

|| 'Popular Science Review,' 1875, p. 358.

The leaf of *Pinguicula* possesses similar bodies, but somewhat different in structure. Fig. 6, *gl* represents their ordinary form. They are considerably larger than in *Drosera*, nearly circular (but apparently flat rather than spherical), and about  $\cdot 0014$  inch in diameter, divided into four quarters, filled with a similar yellowish-brown protoplasmic substance, and each of the quarters distinctly enclosed (in the young state of the gland) in a transparent cell-wall. A circular transparent wall encloses the whole; but there are no enveloping cells similar to those delineated in Fig. 1; nor have I ever observed any papillæ or other processes proceeding from them. They sometimes, however, form slight elevations above the surface, as seen in Fig. 8. At a later period, as shown in Fig. 7, the number of divisions increases, sometimes amounting to as many as eight, and the separating walls of cellulose nearly or quite disappear. A stoma is here again represented, to show the comparative size.

Before commencing my investigations of *Drosera*, my attention had been directed to the occurrence of bodies of a similar nature in a corresponding position in the floating leaves of a common little water-plant, *Callitriche verna*, i. e. beneath the cuticle of the upper surface.\* These bodies were described as long ago as 1850,† by the late Dr. Lankester, who, however, ascribed no special function to them. The glands themselves are more minute even than in *Drosera*, about  $\cdot 0005$  inch in diameter, nearly spherical, and distinctly quadripartite, each division being again filled with a yellowish-brown substance. These are surrounded by a circular border or cell-wall of cellulose, also divided into four, and less opaquely filled up with a similar substance. They are entirely concealed beneath the surface, and do not appear to develop into papillæ. One is represented at Fig. 9, together with a stoma. From the extreme similarity of these bodies to those already described in *Drosera* and *Pinguicula*, the idea suggests itself whether *Callitriche* is not also carnivorous.

The question now arises, What is the purpose of these organs, which present so similar a structure in the plants now described? Is it connected with the absorption and digestion of nitrogenous food presented to the leaves? A direct answer to this question is attended with almost insurmountable difficulties. Unlike the secretive glands of *Drosera* and *Pinguicula*, they are buried in the tissue of the leaf, and it is impossible to place them under the microscope without altogether destroying the surrounding tissue. It is certainly remarkable that bodies more or less analogous to these are present in every plant which has been, down to the present time,

\* I had formerly, but erroneously (*l. c.*, p. 358, footnote), supposed the "rosulate" appearance of the leaves to be due to these bodies.

† 'Proc. Linn. Soc.,' ii., 1848-55, pp. 94, 95.

certainly included under the category of carnivorous. I have already alluded to their existence in *Nepenthes* and *Dionæa*. The bodies described by Darwin under the name of "quadrifids" in the bladders of *Utricularia* bear a strong resemblance to the absorptive glands of *Drosera* after the development of the papillæ; and the drawing, Fig. 30, at p. 448, of the similar bodies in *Genlisea*, a Brazilian plant nearly allied to *Utricularia*, exhibits a still more striking resemblance. No less remarkable is their absence from all plants which do not possess this power; the only exception to this, as far as I am aware, being in the case of *Callitriche*. I have closely examined the leaves of the British plant supposed to have the nearest affinity to *Drosera*, *Parnassia palustris*, without detecting the least trace of them. It is to be hoped that future researches will throw more light on these interesting objects.

---



## II.—*Reproduction in the Mushroom Tribe.*

By WORTHINGTON G. SMITH, F.L.S.

[www.libt.org](http://www.libt.org) (*Coprinus radiatus*, Fr.)

FOR the purposes of minute research into the vital phenomena of the Mushroom tribe, *Coprinus radiatus*, Fr., possesses many advantages over the other species of the large order to which it belongs. The first great advantage peculiar to *C. radiatus* is that it grows readily and abundantly on dunghoops from April to December, and it comes up equally well in town and country. The second point in its favour is that it is so small and transparent that every part can be quickly examined, and an entire plant kept under the covering glass of the microscope. The third advantage found in *C. radiatus* rests in the fact of its whole life being so exceedingly short, that its entire vital functions are performed in a few days. Having these points in view, I have, during the whole of the present summer and autumn, kept up a large bed of fresh horse-dung in my garden, and from this bed I have narrowly watched the growth of many generations of the plant I am about to describe.

A complaint is often made by persons unused to the microscope, and to the appearances of objects as seen by its aid, that it is impossible to see the real objects as they are represented in drawings. To a certain extent this is borne out by facts, for a drawing is never meant to represent what may be accidentally seen at one sitting, but is designed as a summing-up of all that has been seen during many hundreds of sittings. Anyone looking for the first time through a good telescope at Jupiter's moons, Saturn's ring, or the planet Mars, might be a little disappointed in the apparent smallness and lack of strongly marked outlines in the objects seen; but this does not detract from the correctness of astronomical diagrams, which are only matured after many patient observations. No one expects to see the solar system as shown in a model, or the country as seen on a map.

It may reasonably be premised that the facts observed in connection with the life history of *Coprinus radiatus* will more or less apply to all the other species belonging to the Mushroom tribe; but it would be impossible to make the observations here recorded on the more fleshy species, because, instead of days, these latter plants take months to mature. In *C. radiatus* generation after generation keeps springing up in almost daily succession, but in the more fleshy species, exclusive of *Coprinus* and *Bolbitius*, I am convinced there is, as a rule, but one generation in the year. The common Agarics of the autumn spring up from the mycelium formed during the fall of the previous year, and this mycelium has

rested in the ground for twelve months. In digging up old pasture ground, or the dead leaves of an autumn which has passed, mycelium in a resting state is invariably found. There is no such long rest with the mycelium of *Coprinus radiatus*, for so long as the weather is not too dry, too wet, or too cold, the fungus goes on perfecting itself day after day without ceasing. During hot, very wet, or frosty weather the spawn lies buried, and it rests in the warm, moist dung for short periods of time only.

*Coprinus radiatus*, Fr., is one of the dung-borne Agarics with a cap which measures from an eighth to one-quarter of an inch in diameter, and this filmy pileus is supported on a stem, which on an average measures from a quarter to three-eighths of an inch or more in height (Figs. 1 and 2, A). The whole cap is a mere transparent film, and the fragile stem is like an atom of gossamer thread. A breath will totally break down and collapse every part of the plant, whilst a heavy dew or slight shower of rain will destroy a whole colony. These minute Agarics can only be gathered with the aid of small forceps, for if they are taken in the fingers they at once collapse, become liquid and vanish. So little moisture does a single specimen contain that it is lost in the moment or two consumed in taking it for examination from the garden to the house. The young plants may generally be seen dotted over the dung, like in size to so many pins' heads (Fig. 1, B), and from this, the infant state, to maturity, the growth of the fungus is very rapid. At seven or eight in the evening nothing but immature plants can be seen (Fig. 1, C, D, enlarged 20 diameters); about eleven or twelve a rapid growth commences, and by two or three o'clock in the morning the full size is reached. If the morning is moist the plants will remain in perfection till nine or ten o'clock, but if it is dry they will not last after five or six. On shady roadsides or in dark places the time required for growth may probably be a little more or less, but the present observations apply to the plants as found growing on dung in a light and open place.

To get a good view of *C. radiatus* it is necessary to magnify it at least from 50 to 100 diameters; the nature of the stem and gills can then be made out, and all the individual component cells be clearly seen.

Mature plants are figured at E, F (Fig. 1), enlarged 10 and 20 diameters, the first showing the nature of the outer surface of pileus, with its furrows, and the other the lower or fruiting surface, with the nature of the gills, and the collar formed by them near the insertion of the stem. At G is shown the relative number of the basidia or privileged cells, which carry the naked spores, and at H the relative number and position of other privileged cells, termed cystidia. To these latter bodies I shall presently refer more fully, and they are merely adverted to here that some idea may be formed

8 *Reproduction in the Mushroom Tribe.* By W. G. Smith.

of their great number. At I is shown a horizontal section through the cap of the fungus, a short time before expansion (when the

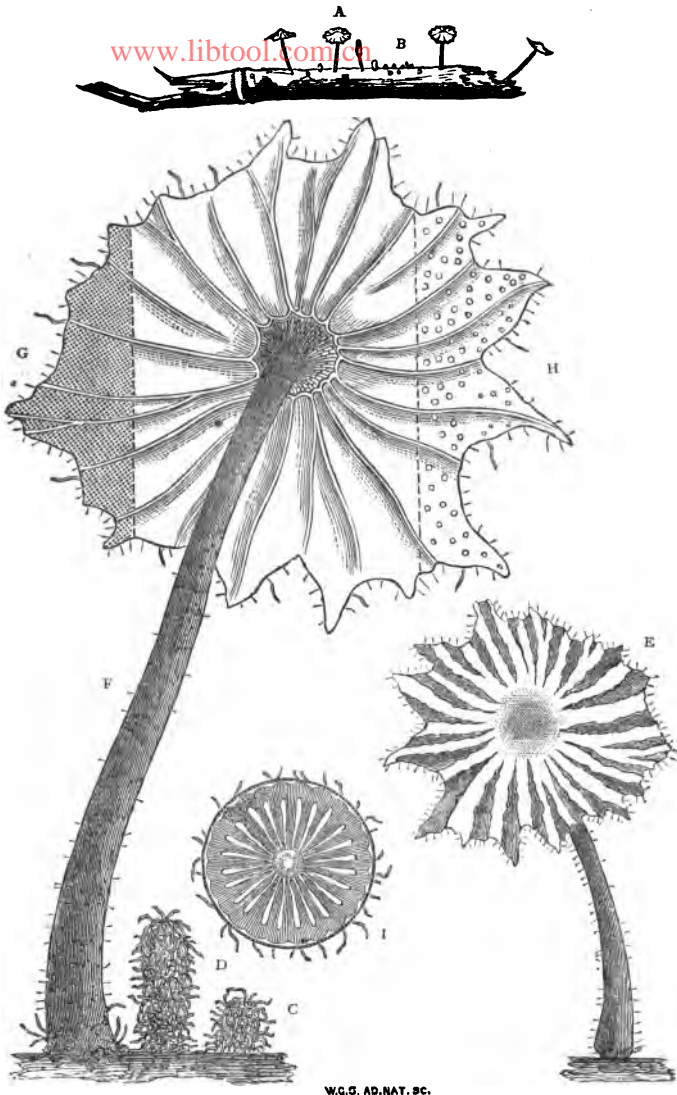

W.G.S. AD. NAT. SC.

FIG. 1.\*—*Coprinus radiatus*, Fr.

A, Natural size; E, Enlarged 10 diam.; other figures, 20 diam.

\* The blocks have been kindly lent by the Editor of the 'Gardeners' Chronicle.'

umbrella-like top is down), to show that the hair-like stem is hollow, and that the plant in infancy is enveloped in a complete

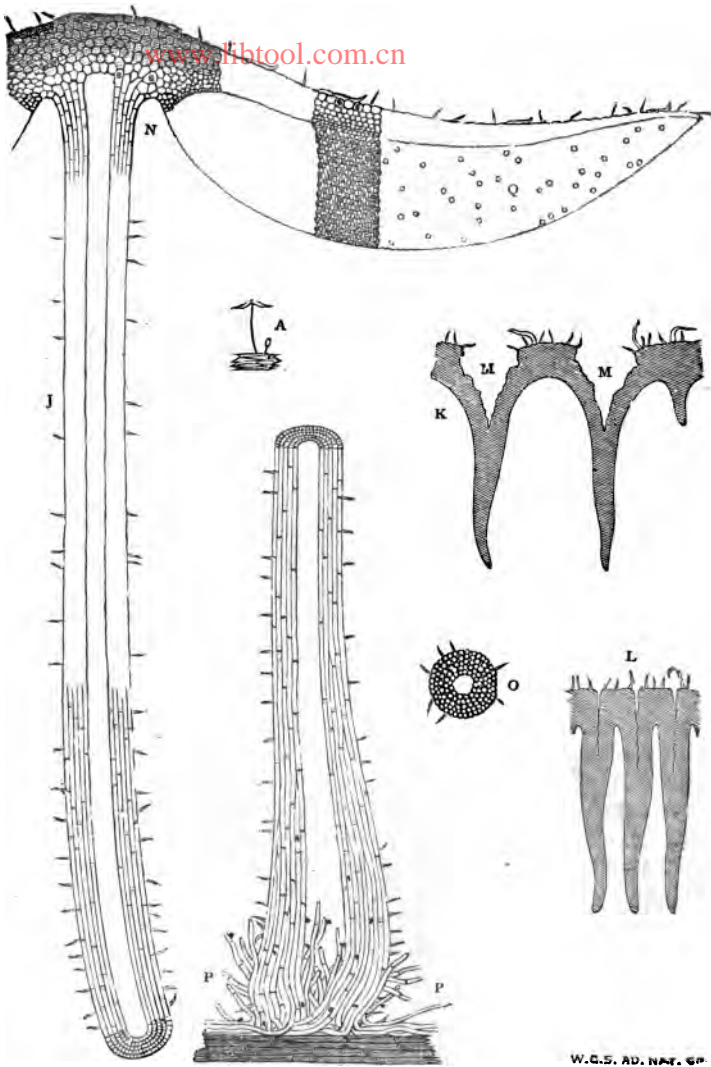

FIG. 2.—*Coprinus radiatus*, Fr.  
Enlarged 50 diam.

veil or bag, the presence of which is shown by the ring of cells and hairs which forms the circumference of the diagram.

For a proper comprehension, however, of this minute fungus much more than a superficial examination is necessary, and the first thing to be done in the way of dissection is to secure a good longitudinal section of the fungus from top to bottom, as shown in Fig. 2 (J); this enlarged 35 diameters, at once shows the immense number of cells which go to make up one of the fugitive little plants belonging to *Coprinus radiatus*. By reference to the figure it will be seen that the stratum of flesh which forms the pileus is only six or seven cells in thickness, and the external surface is covered with a few hairs of different sizes (the remnants of the universal veil or wrapper), some of the smaller hairs being tipped with a gland. Another good vertical segmental section across the cap and gills will show the appearance of the plicato-radiate outer surface of the pileus to be caused by a series of cracks which are brought about by the necessarily sudden expansion of the cap, which act of expansion tears (in these positions) the component cells of the pileus apart, Fig. 1, E, and Fig. 2, K. A transverse section through the fungus when in an infant state shows the commencement of these fissures, as at Fig. 1, I, and Fig. 2, L. The gills have no trace of a trama, the so-called trama being the cells which form the substance between the hymenium in the gills; if present this substance would be at M M, Fig. 2; but one of the characters of the genus *Coprinus* is that the gills have no distinct immediate substance in the gills. In the plant under examination the lamellæ or gills are free from, and form a collar round the stem (Fig. 2, N), and are only about seven cells in thickness.

Good sections down and across this stem when young will show it (gossamer-like as it is) to be piped or hollow from top to bottom (Fig. 2, O), and the hairs seen at the base (P P) are the torn remains of the veil or wrapper which once held the edge of the pileus (Q) down to the base of the stem. In this figure several spores may be seen at the base, carried up amongst the cells of the stem. On looking at an entire plant of *C. radiatus* in this way under a low power of the microscope it appears to be formed of a few thousands of cells only, but if these cells are now measured and counted, which is by no means a difficult matter, it will be found that instead of thousands it really requires millions of individual cells to build up one of these minute plants which a breath destroys. The smallness and lightness of one fungus is such that it requires 150 specimens to weigh a grain, or 72,000 to weigh an ounce troy. In the type specimen of *C. radiatus* now figured there were 22,560,000 cells in its structure irrespective of the spores, which numbered about 3,200,000 more. If all these cells and spores are only equivalent to the hundred-and-fiftieth part of a grain, it follows that in an ounce of fungus cells there must be no less than one billion six hundred and twenty-four thousand millions of these

bodies, exclusive of the spores. In a large Mushroom the cells would number hundreds of billions. Still more wonderful is the fact that each individual cell is furnished with a spark of life, contains water, protoplasm, and other material, and is capable of growth and assimilation.

The purpose of this essay is to demonstrate something of the life history of the minute but truly wonderful fungus now before us; and with this object in view it is not only necessary to use the higher powers of the microscope, but to patiently watch the fungus and its changes at every hour (almost minute) of the night and day and for several days in succession.

In the vertical section of one of the minute gills, as shown in Fig. 3, magnified 150 diameters, the whole fruiting and reproductive surface of the fungus is seen at a glance. The nature of the furrows in the pileus (R) is now perfectly clear, every cell being seen in position, and the remnants of the universal veil or wrapper are seen on the surface of pileus at S. Studded amongst the cells of the upper stratum of cap may be seen various brilliant crystals which belong to the ammonio-phosphate of magnesia, and which crystals are taken up by the fungus from the manure on which it grows. Many dung-borne *Agarics* are covered with so-called micaceous particles, which, in many instances, doubtlessly arise from the manure which supports the fungus. It is a matter of considerable difficulty to get a section like this, for if attempted clumsily no result will follow beyond a slight discoloration of the edge of the lancet; it is necessary to take the slice at the exact moment of maturity, and even then it requires the perfection of dexterity to cut the fungus properly, as the plant is sticky in all its parts. A fragment of the fruiting surface of a gill is shown at T.

To understand the vital phenomena of *C. radiatus* it is necessary to comprehend the meaning of the bodies seen in Figs. 3 and 4. The whole fungus is built up of cells, which run parallel with each other (and at maturity are very long) in the stem (Fig. 2), and which spread laterally, and then become more or less spherical in the pileus. When these cells reach the gills or fruit-bearing surface (hymenium, U U), a certain differentiation takes place in their functions. The majority of the cells remain simple, but certain other cells which are spread over the gills with the greatest regularity assume a different nature, and produce spores. These cells are called basidia (meaning small pedestals, V V, Figs. 3 and 4), and the spores, or analogues of ovules or seeds, basidiospores, because they are carried on these little pedestals. The minute threads between the spores and their pedestals are termed spicules or sterigmata (literally props). Certain other privileged cells (W W, Fig. 3) are termed cystidia (bladders), and around these latter organs and their meaning the principal interest of the





basidia being female, and the cystidia the male organs. When the contents of the basidia and cystidia are interchanged, the result is a

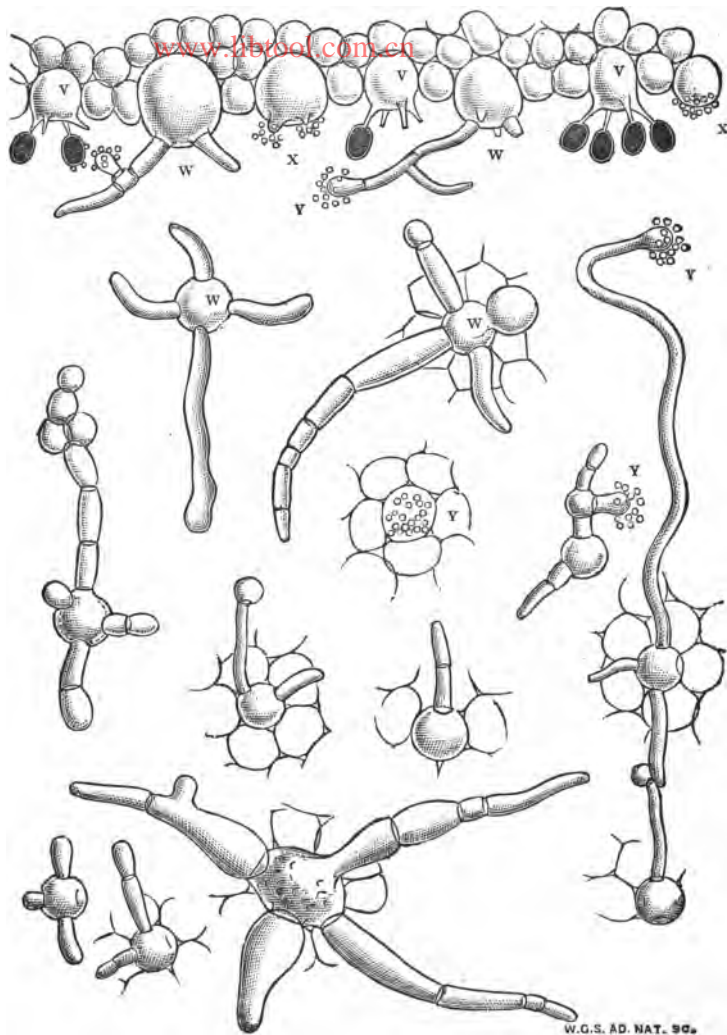

FIG. 4.—*Coprinus radiatus*, Fr.

V, Basidia bearing spores; W, Cystidia; X, Y, Spermatozooids.

return to another series of cells, which go to form a new plant. I am perfectly aware of the opinions which have been expressed by other botanists (and to which I shall return), but it is not so much



my aim to make my observations accord with what others have said, as to record what I have seen myself, and to give my own interpretation of the phenomena seen, irrespective of what has been said or done before.

The first sign of differentiation in the simple cells of the gills, when the basidia and cystidia are about to be produced, is in the privileged cells becoming glossy, crystalline, and translucent: they both appear to secrete a material which makes them conspicuously brilliant. Each basidium then throws out four slender branches, the tips of which gradually swell and form spores. The cystidia (W) are more sparingly produced (for their number in this species, see Fig. 1, H, and Fig. 2, Q), and at first cannot be distinguished from the basidia, though they are frequently larger in size; they are commonly granular within, and are in many species, as in the one before us, crowned with granules, W (Fig. 4, X), but sometimes they bear four spicules, and this latter condition has led some botanists to consider the cystidia to be barren basidia, but that they are really cystidia with spicules is proved by the following fact, which I believe to be somewhat new. In moisture, as supplied by the expressed juice of horse-dung (or even distilled water) these spicule-bearing cystidia germinate at the four points of the spicules, and produce long threads, which bear at their tips the granules so frequent in typical cystidia (Fig. 4, Y). The cystidia are moreover furnished with spicules in the subgenus *Pluteus*. The germinating cystidia are seen in several places at W, Figs. 3 and 4, and the granules at X, Y. On the top of Fig. 4 is seen a section of a gill with all the bodies in position enlarged 350 diameters, whilst on the lower part of the cut may be seen various germinating cystidia to the same scale as seen on the surface of a gill. The granules at Y, which are at first not capable of movement, are really spermatozooids possessed of a fecundative power, but to see this power brought into operation considerable care and patience and the higher powers of the microscope are requisite. In certain other of the *Agaricini*, the protoplasmic contents of the cystidia are at times discharged from one mouth only and that at the apex of the cystidium.

Before quitting Figs. 3 and 4, I may say that when a slice, as represented in Fig. 3, is placed under a covering glass in a drop of water, all the cells totally collapse and vanish, so that in three or four hours not a vestige remains, but the same drop of water which destroys the old cells instils life into the granules or spermatozooids, which after the lapse of a couple of hours begin to revolve, and ultimately swim about with great rapidity. These spermatozooids attach themselves to the spores, pierce the coat, and discharge their contents into the substance of the spore. From twenty-four to forty-eight hours after this the spore discharges a cell which soon becomes free, and this is the first cell of the pileus of a new plant

which rapidly produces others of a like nature (Z, Fig. 3). Now the same water which had the effect of immediately collapsing and destroying the old cells, has quite a different effect on the new cells as discharged from the fecundated spore, for the whole development of the new plant depends upon the constant presence of moisture, expressed juice of horse-dung being perhaps best. A spore unpierced by the spermatozoids is shown producing a mycelium peculiar to itself, at A, Fig. 3.

A spore is commonly considered to have some analogy with a seed, but according to my views its analogy is rather with an unfecundated naked ovule without an embryo, unless the nucleus within the spore may in some way represent the rudimentary fungus; when the spores are formed within sacs or asci, the ascus bears some analogy with the ovary. The cystidium, on the other hand, represents with its granules the anther and its pollen.

The six spores represented on the top of Fig. 5 are magnified 1000 diameters, and each viscid spore, which is furnished with a nucleus lighter in colour, but with a dark outline, has been pierced and fertilized by one or more spermatozoids, whilst the unfertilized spore at A has burst at both ends, and produced a mycelium of its own. At B may be seen three spermatozoids which have burst after twelve hours in expressed juice of horse-dung, and which have also produced branching threads peculiar to themselves, reminding one of a pollen tube. It is quite possible that these latter threads may help to produce a new plant if they come in contact with the spores. The large figure at C is similar in nature to the group at Z, Fig. 3, and represents three fertilized spores which have burst and produced the first minute knot or groups of cells of the cap of a new fungus. These eighteen cells took four days for their production, and the crystals belong to the expressed juice of the horse-dung in which they grew. The spermatozoids as here shown begin gradually to revolve after being kept in liquid for two hours, and the movements last for at least four days. At first these bodies are perfectly spherical, as at D, when they merely oscillate, then they revolve slowly, and as time goes on, a single turn of a spiral makes itself visible, and the bodies whirl round with great rapidity. At intervals the motion entirely ceases, and then, after a short lapse of time, the gyration is again continued.

Judging from the presence of the eddy round these bodies whilst whirling (E E, Fig. 5), they are possibly provided with cilia, but from the extreme minuteness of the bodies themselves I have not been able to satisfactorily demonstrate their presence. The whirling of the spermatozoids is sometimes so strong that when they attach themselves to the spores they twist them round after the manner of the revolving oosphere in *Fucus*.

When the cells of the old parent fungus collapse and disappear

in the water, their place is in less than two hours occupied by innumerable quantities of bacteria, vibriones and monads, which belong to the infusoria. In these two hours every cell of the pileus

[www.libtool.com.cn](http://www.libtool.com.cn)

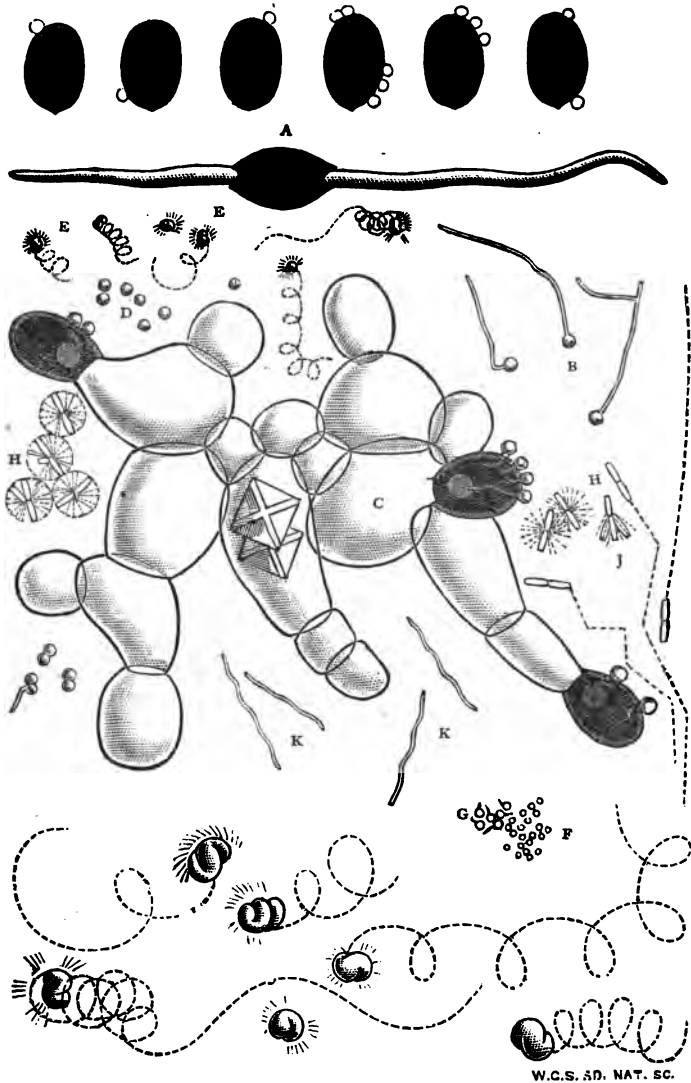

FIG. 5.—*Coprinus radiatus*, Fr.

Spores, Infant plant C, and Infusoria, enlarged 1000 diam.; Spermatozooids at bottom further enlarged to 3000 diam.

has generally vanished. Where these infusoria come from, or how they so speedily come into being, is difficult to say. They may possibly be present in a latent state in the juices of the fungus, but I have invariably found, when a single specimen of *C. radiatus* has been placed on a slide under a covering glass with a drop of water, and this, again, under a propagating glass, that as the millions of fungus cells quickly disappear, so millions of simple infusoria just as quickly come into being. It seems almost reasonable to believe that the fungus cells themselves become suddenly transformed, and reappear as simple infusoria; the change would not be quicker or more remarkable than the rapid production of the purple-black spores from the crystalline and colourless basidia.

Be this as it may, I have here engraved the abundant infusoria to the same scale as the cells. The tailless monads at F have a rocking Brownian movement, whilst those with tails, G, propel themselves rapidly about after the manner of minute tadpoles. These monads are liable (without care) to be mistaken for the bodies I refer to spermatozoids, from which they are, however, very different. The bacteria are represented at H H, with their various movements (indicated by dotted lines), either straight, zigzag, or rapidly revolving on a central axis; when they so revolve they cause a miniature vortex amongst the monads and atoms. I have commonly seen one segment move from side to side, as at J, whilst the other segment remained quiescent. I have also seen them bud from the centre, and occasionally they occur with three limbs instead of two, radiating from the central axis. The vibriones are like vegetable screws, and are shown at K. The spores and infusoria neither collapse nor burst in boiling. As for the monads, vibriones, and bacteria, it can hardly be admitted that they are generated spontaneously from inorganic materials; my experiments rather point in the direction that they are only differentiated forms of already living cells. However this may be, my boiling has not destroyed either vitality or form, and those interested in the subject of spontaneous generation may possibly read the result of the following experiment with interest. A dozen semi-decayed specimens of *C. radiatus*, swarming with minute infusoria, were boiled in a test tube for five minutes and then hermetically sealed at the highest point of ebullition. At the end of a month the tube was opened and a drop of its liquid contents at once placed under a cover-glass of the microscope for examination. Spores, cells, monads, bacteria, and vibriones were all there, but the latter motionless and apparently dead. In fifteen minutes, however, they showed signs of life, and began to slightly move about; in thirty minutes the movements were decided in nearly every specimen seen; whilst in sixty minutes the infusoria darted about with almost the same energy as they did before they were boiled. For a better

appreciation of the exact form and gyrations of the spermatozooids they are shown again at the bottom of Fig. 5, enlarged 3000 diameters. At first it requires long and patient observation to make out the form of these bodies satisfactorily, but when the peculiar shape is once comprehended there is little difficulty in correctly seeing their characteristic form. The difficulty is something like that experienced by beginners in separating very small and close double stars with a telescope; at first and sometimes for a long period only one star can be seen, till quite suddenly the two are made out, and they are seen as two ever afterwards.

It is not uncommon to find the spores of other dung-borne fungi sticking to the specimens of *C. radiatus*, and it is quite frequent to find not only the spores but the perfect asci of certain species of *Ascobolus* sticking to the under surface, to which position they have been projected from the plants of *Ascobolus* growing on the dung. I have also seen the eggs of various mites, nematoid worms, &c., carried up amongst the cells, which quite accounts for larvæ being found within the substance of apparently sound fungi.

In the works I am acquainted with there is no mention of the cystidia falling bodily out of the hymenium on to the ground, yet this is the case in several *Agarics* I have examined, and is so with *C. radiatus*. The spores naturally fall to the earth, and with them the cystidia, and it is upon the moist earth that fertilization is generally carried out. All botanists will remember Hoffmann's observations, where he has indicated the passage of basidia into cystidia, and his remarks on the upper surface of the ring which grows round the middle of the stem in *Agaricus muscarius*. In this latter position Hoffmann found a quantity of gelatinous knots, from which projected one or more oscillating threads, terminated frequently with a little head, which occasionally becomes detached. My interpretation of these observations is, that Hoffmann lighted upon the fallen cystidia on the upper surface of the ring, where they were throwing out threads. Hedwig made somewhat similar observations on the ring in *Agaricus*.

From the condition of the infant plant, as figured on the hymenium, Fig. 3, Z, and Fig 5, C, it is easy to trace the young fungus through the various stages of its growth, as seen at Fig. 6, where the figures are all enlarged 500 diameters; the lower group of cells shows a plant of seven days' growth in the expressed juice of horse-dung. In all these figures it will be seen that crystals and spores are carried up by the cells, and the lower figure conclusively shows that the first cells of the new plant are the large ones which belong to the pileus; indeed the hairs of the pileus as here shown are amongst the earliest cells produced, these hairs and the threads of the mycelium (which is always highly granular near the plant) are almost one and the same in character. In Fig. 6 and

Fig. 7 the infant fungus resembles a Puff-ball, to which it indeed bears a certain natural relationship. The whole plant in infancy

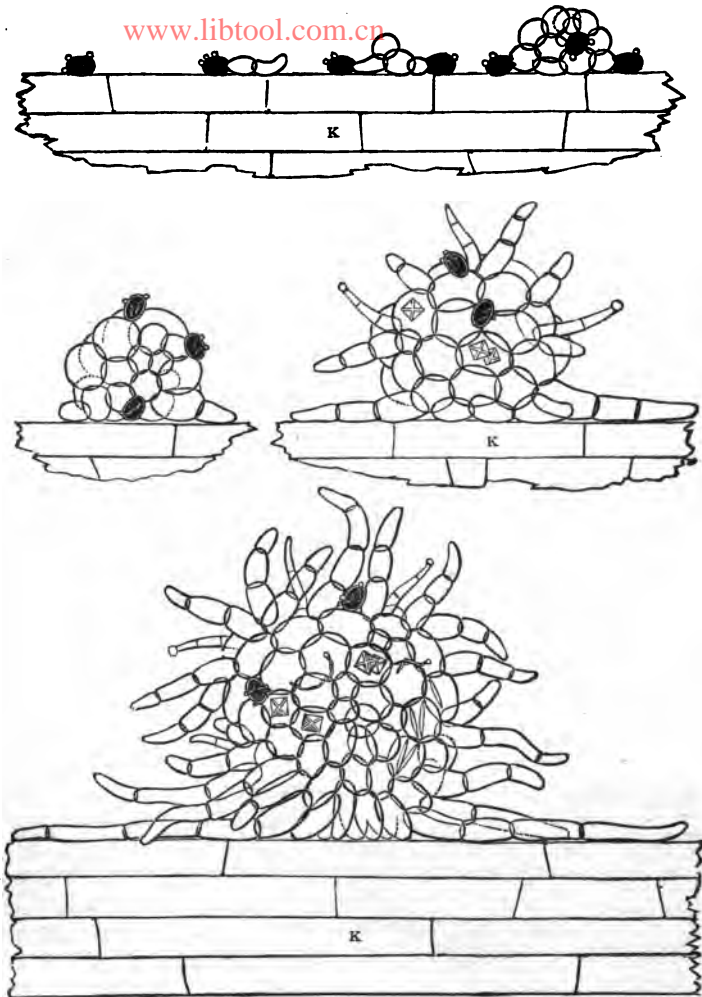

W.C.S. AD. NAT. SC.

FIG. 6.—*Coprinus radiatus*, Fr.

Enlarged 500 diam., as grown from the spores, in expressed juice of horse-dung, under a covering glass of microscope.

is enveloped in a wrapper of cells, the fructification being entirely concealed within. In the lower figure on Fig. 6 may be seen two spermatozoids which have burst, and K K K shows the cells of straw.



When the fungus has made about the number of cells represented on the bottom of Fig. 6, the growth cannot be carried any

[www.libtool.com.cn](http://www.libtool.com.cn)

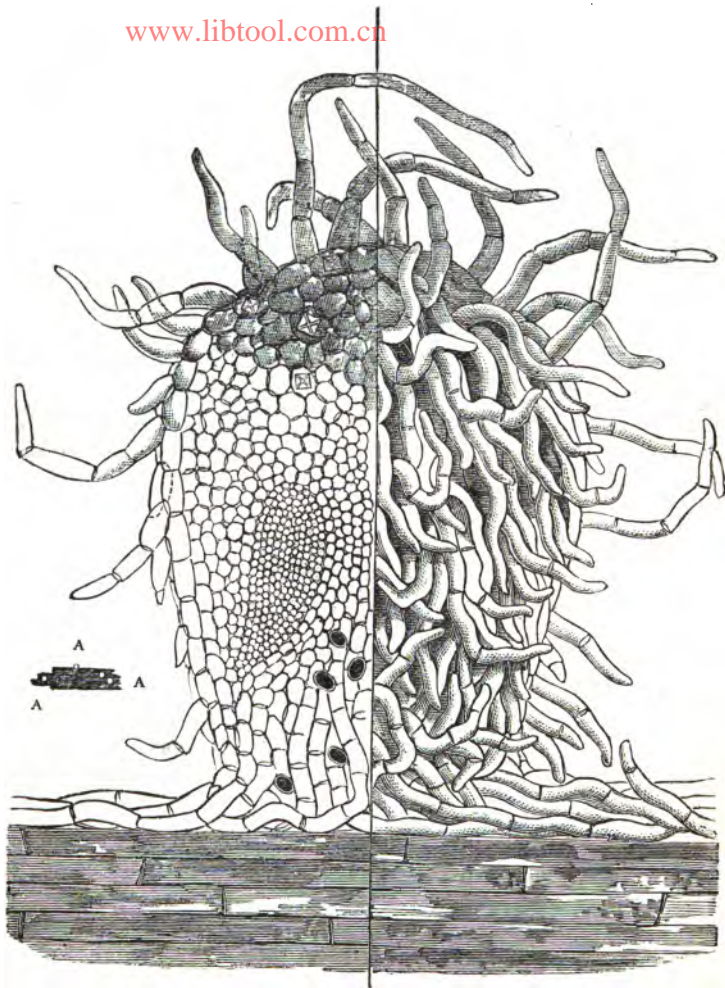

W. G. S. AD. NAT. SC.

FIG. 7.—*Coprinus radiatus*, Fr.  
Enlarged 200 diam., and natural size at A A A.

further beneath a covering glass. Fig. 7 represents on one side the elevation, and on the other the section of the very smallest infant plant it is possible to see with a lens on the dung. The

fungus represented is magnified 200 diameters, and the original was about half the size of a pin's head (see A A A sketch in margin). The nature of the hairy coating, which forms the veil and the cells which are to form the future gills, are here clearly seen. This figure shows the fungus in its Puff-ball condition at the time when the cells are being actively produced. It contains only a small proportion of the actual cells which go to make up a perfect fungus, and represents probably a full week's growth from the spores. How it is that the cells have an inherent property of building themselves up into a particular design, no one knows any more than it is known how the fine spark of life is kept up in these cells from one generation to another.

The mycelium now grows in a radiate manner from the base of the young plant, just as a germinating seed throws up a plumule and throws down a radicle. This mycelium being the produce of fertilization is now capable, under certain conditions, of producing new plants on certain spots on the threads. Spores are now unnecessary, in the same way as fresh seeds are unnecessary where the creeping root-stock of Couch-grass is present. Or the mycelium may go to rest in the form of cords or thick threads, when it is termed Rhizomorpha, or in the form of the knots or bulblets known as Sclerotia. A similar state of things is common in many perennial flowering plants, as *Convolvulus sepium* and *Sagittaria sagittifolia*, and they both at first arise from a seed in the same way as a Mushroom arises from a spore. In Mushroom-spawn the grower gets a material similar in nature to the root-stock in Couch-grass.

Fig. 8 and last represents, enlarged 120 diameters, *C. radiatus* a few moments before expansion, when nearly all the cells are present. Most of the cells here shown are, however, only about one-half the size they reach at maturity, and they are not all and every one produced till the exact moment of complete expansion, as I have ascertained by counting the cells of many specimens. This is not to be wondered at, for if the 22,500,000 cells which go to make up one of these minute plants require fourteen days for their production, it follows as a necessity that the cells go on multiplying all the fortnight, night and day, at the rate of 1114 to the minute. It takes about five hours for the spores to be gradually produced all over the hymenium—say from 5 to 10 o'clock in the morning, and as there are upwards of 3,000,000 spores to each plant, they as a consequence gradually appear upon the basidia or spore-bearing spicules at the rate of 100,000 every minute.

No sooner has the plant arrived at perfection than that very moment it begins to perish. I have demonstrated that the cells of the pileus and the hairs which form the veil are the first to appear, and so they are the first to disappear. The fine matted hairs



which form the veil in Fig. 8, B B B, are all torn assunder during the few moments consumed in the expansion of the cap, and at the

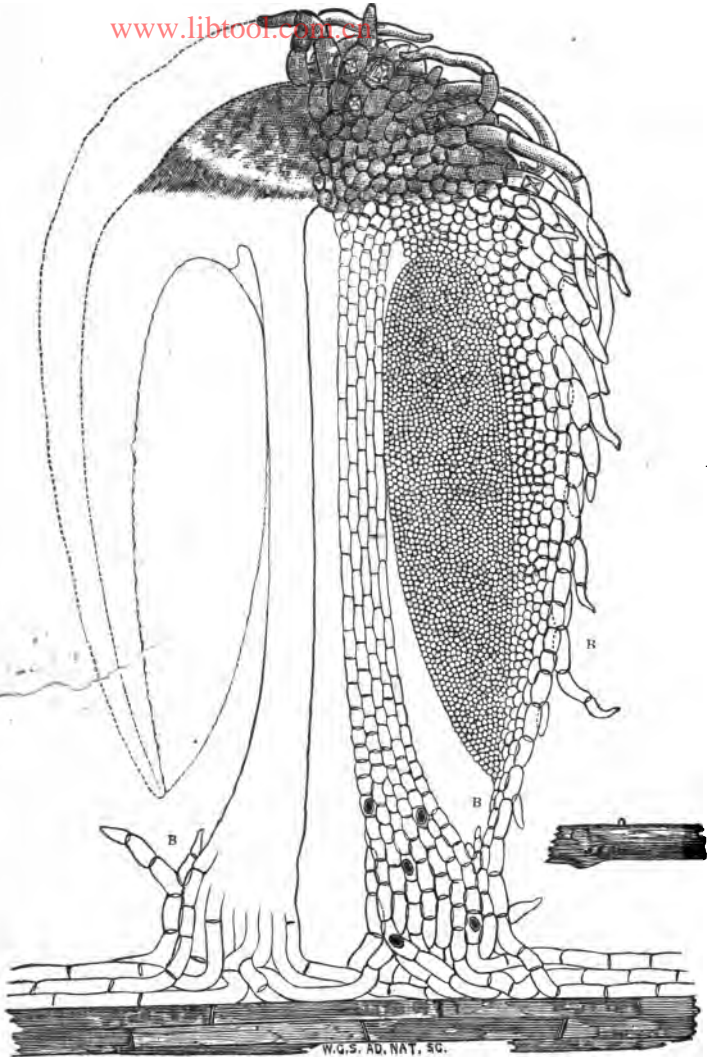

FIG. 8.—*Coprinus radiatus*, Fr.  
Enlarged 120 diam.

moment of maturity the hairs vanish and the pileus is naked, which nakedness is the first sign of its decay. When the fragile little

fungus has at length produced its fruit, and is prostrate and dying upon the matrix from which it sprang, then, as can be seen with patience under the microscope, the cystidia produce spermatozoids which are at first passive and then active; these pierce the spores and cause the discharge of the first living cell of the pileus of a new plant. It will be seen from these observations that *C. radiatus*, though one of the most minute and fugitive of all the Mushroom tribe, is yet as completely perfect in all its parts as any of the larger and higher species of *Agaricus*. It must not be supposed that these observations can be followed without close attention and the utmost patience. All the 3,000,000 spores of the fungus do not grow and make new plants, or the world would soon be covered with *C. radiatus*. For every spore that is fertilized and grows, there are millions which necessarily perish.

On a dunghheap which will produce *C. radiatus*, other species, as *C. nycthemerus*, &c., are sure to appear; and not only do allied species come up in company with *C. radiatus*, but every intermediate form between one and the other may be gathered any morning. These latter plants belong to no species described as such, but are natural hybrids, doubtlessly produced by the spermatozoids of one plant piercing the spores of another. Amongst the larger species of *Agaricus* similar forms are quite common, and they prove sore puzzles for those men who only want names for the fungi they find. I am convinced that at least three-fourths of the described species of the higher fungi have no claim to rank as true species, and that plants like *Agaricus procerus*, *A. rachodes*; *A. excoriatus*, *A. gracilentus*, with others, are mere forms of one and the same plant, and every intermediate form may be met with.

Van Tieghem has recently been working on this species, and he has arrived at the conclusion that the fungus produces spores of different sexes. But to me it is quite unreasonable to imagine seeds or spores to be of different sexes. Known facts point quite in the opposite direction; and if sex is once allowed in seeds and spores, then we must be prepared to allow sex in pollen and spermatozoids. A spore or ovule must be considered female, whilst unfertilized or still in the ovary, but when once fertilized it combines both sexes and cannot be other than hermaphrodite. A secondary colour, as orange (which combines the red and yellow primaries), can never be red or yellow. In dioecious plants the seeds are capable of producing either sex, and are not themselves male or female; and even the great fleshy root-stock of *Bryonia dioica* will be male in one place, and if removed to a different position be female. The Rev. M. J. Berkeley, writing of *Coprinus*,\* says: "Late examinations of the spores of some *Coprinus* under germi-

\* 'Gardeners' Chronicle,' April 17, 1875, p. 503.

nation seem to show that impregnation takes place at a very early period."

Now my observations show that this impregnation often actually takes place on the hymenium itself, the product being a single cell, which in the species now described rapidly develops into a new individual. The spore and spermatozoid may be considered as somewhat analogous with an ovule and a pollen grain, or with what is seen in *Chara*; or like the escaped oosphere and spermatozoids in *Fucus* amongst the *Algæ*.

I cannot attach much importance to *Cersted's* interesting paper on the fructification of the *Agaricini*. His notes are on *Agaricus variabilis*, a plant he gathered from a Mushroom bed. Now, as far as my experience goes, *A. variabilis* is peculiar to dead stems, sticks, and leaves, and does not grow upon dung. Moreover, *Cersted* experimented upon threads of mycelium taken from dung, and presumed only to belong to this *Agaricus*; but this mycelium was quite as likely, in my opinion, to have belonged to fifty other things. *De Bary*, speaking of *Cersted's* observations, says: "It is impossible not to perceive the similitude between the phenomena seen by M. *Cersted* and those I have described in *Peziza confluens*." It is quite doubtful whether or not *Cersted* had got the mycelium of some dung-borne *Peziza* for his experiments, as *P. vesiculosa*, which is always present on dunghoops.

In the observation of natural phenomena it is never well to follow, without thought and original observation, in the footsteps of others. In the case of *Peronospora infestans*, because *De Bary* said the resting spores were not likely to be found in the Potato plant, it was almost universally accepted as a fact that they never could be there found. Because conidia had not been described, it was commonly believed that no conidia existed. The mycelium of *Peronospora* has till lately been described as always destitute of suckers, but in some of the *Chiswick* plants the suckers were abundant. The same fungus is commonly described as having its threads without articulations or septa, but it is equally common to see the fungus and the figures of it too with septa in profusion.

Many botanists, as *Corda*, *Bulliard*, *Klotzsch*, and others, have considered the cystidium in *Agaricus* to correspond in some way with an antheridium; but as these views have not at present been favoured by *Tulasne* and *De Bary*, many botanists seem disposed to agree with *De Bary* in regarding the cystids as mere "pilose productions of a particular order," which is very indefinite, and the granules as mere conidia (*Tulasne*). *Klotzsch* and others have considered it possible that the spores are fecundated by a lubricating fluid given out by the cystidia. This fluid is evidently the same with the threads observed by me, and which at length gives birth to spermatozoids. I consider it quite possible that the mere contact

of the threads (or fluid) from the cystidia with the threads from the unpierced spores may be sufficient for the production of a new plant. But De Bary, in criticising Klotzsch, says an opinion of this nature is **entirely gratuitous**, and the contact and its result, if real, would represent nutrition rather than fecundation, and, as far as he knows, there exists, he says, no other observation on any female organ susceptible of fecundation by the cystidia. I cannot fall in with De Bary's views at all, especially after the analogy found in *Fucus* and in the confervoid pollen (which has no outer coat), and which exhibits rotation in the flowering plants found under *Zostera*, *Phucagrostes*, &c., and which are fecundated when in a state of immersion in water.

As regards the spores of woody species of fungi, they are probably fertilized on the parent plant, and are blown away by the wind in a condition suitable to at once form the first cells of a new plant on any proper habitat. If Agarics were perennial and persistent, instead of being annual and fugitive, we might expect to see a new hymenium produced each year upon the lower surface of the old one, and this state of things really does exist in many species belonging to the perennial and persistent woody fungi of trees, where a new stratum of tubes is every year produced underneath the old one, so that the age of the fungus in years may be correctly ascertained by merely counting the strata. As to the mycelium itself, and the possibility of its producing sexual organs in Agaricus, I have had the subject before me for many years, and have seen many germinating spores, but no trace of any sexual organ other than the spermatozoids as produced from the cystidia themselves, or from the protoplasmic filaments which they throw out. I am therefore disposed to believe that the absence of sexual organs on the mycelium is owing to the threads being the produce of fertilization.

As for the expressed juice of horse-dung, it abounds with nematoid worms, spores and infusoria of many kinds—no drop can be examined from a dungheap after a shower of rain without seeing large quantities of these organisms. Therefore, any uncertain thread taken for examination from dung is sure to lead to error. All my experiments were carried out in duplicate, one with expressed juice, and the other with distilled water, with very little difference in result, as the new plant seemed to live principally on the remains of the old parent.

As a proof of how much there is still to be learnt respecting the life history of Agarics, I may say that in Sach's recently published 'Text Book of Botany,' one of the very best and most complete books of its class ever published, there is no mention whatever made of cystidia in the description of Agaricus, and in La Maout and Decaisne's 'Descriptive and Analytical Botany,' under

fungi, it is stated that the male organs never produce antherozoids, and that the cystidia are always deprived of sterigmata or spicules.

To repeat and follow out these observations it is necessary to take the specimens for examination exactly at the proper period of growth, and to exercise the greatest care in securing a uniform moisture between the glasses. The life of the fungus is so short, and all the characters are so evanescent, that the points to be observed may be present one moment and all gone the next.

All the drawings have been made with a camera-lucida, and from different specimens, so where the dimensions of the parts slightly disagree, it is only such a disagreement (within defined limits) as is commonly found in Nature.—*Gardeners' Chronicle*, October 16 and 23.

### III.—Avoiding the Use of the Heliostat in Micro-photography.

By G. M. GILES, M.M.M.S.

PLATE CXXVII.

SOME time ago I commenced to make some experiments in micro-photography. I did not wish to set aside a room to act as a camera, as in the method of Colonel Woodward, and did not like the form of instrument mentioned in the catalogues of the instrument makers, as in the first place it is very top-heavy, and in the second the disk produced, I found on inquiry, was no larger than a "five-franc piece." Above all things I wished to avoid the necessity of using a heliostat.

I was therefore constrained to contrive an apparatus to meet these requirements, which I have no doubt are those of a great many histologists. The image produced by an ordinary condenser of short focus is so small, that unless a heliostat be used, it is almost impossible to replace the focussing screen by the sensitized plate before, on account of the rotation of the earth, the image has passed across the field of the instrument and disappeared. Now the obvious

#### EXPLANATION OF PLATE CXXVII.

- Figs. 1 and 2, *a*.—Stand of camera.  
 " " *b*.—Mirror.  
 " " *c*.—Long-focussed condenser.  
 " " *d*.—Microscope and its slider.  
 " " *e*.—Grooved wheel at back.  
 " " *f*.—Strings of horizontal movement.  
 " " *g*.—Strings of vertical movement.  
 FIG. 3.—Section mode of connection of microscope with camera.  
 " 4.—Sectional view of "tramway."

*Plan.*

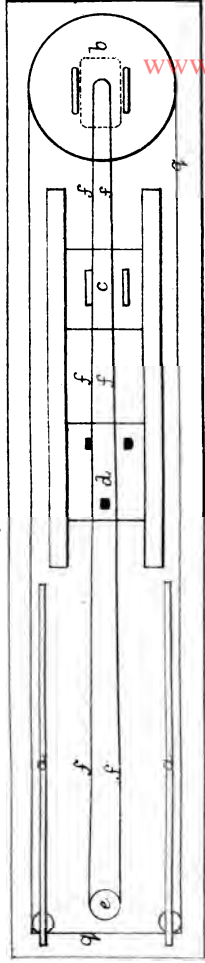

Fig. 1.

*Elevation*

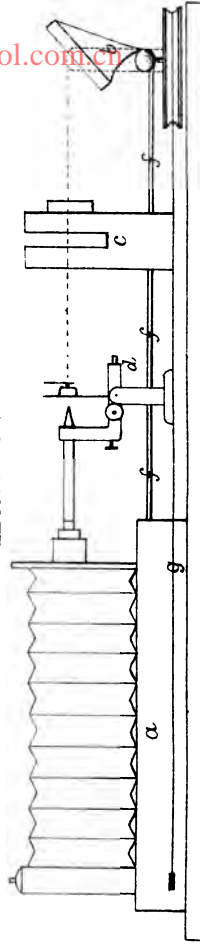

Fig. 2.

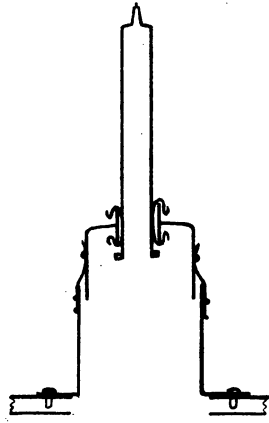

Fig. 3.

Fig. 4.



[www.libtool.com.cn](http://www.libtool.com.cn)



remedy for this appeared to me to enlarge the disk of light that is thrown on the object. By putting the condenser out of focus one obtains a larger disk, but this at the expense of a great loss of light, besides which circles of varied colours are thus produced of equal variety of actinic power.

In order therefore to produce a sufficiently large image, I determined to make use of a telescopic objective as condenser, instead of the usual short-focussed lenses that are used for this purpose.

The glass ultimately employed was an achromatic, photographic, single combination of  $3\frac{1}{2}$  inches diameter, and about 10 inches focal length.

The employment of this condenser necessitated other changes which have resulted in the form of apparatus I am about to describe.

It consists of a strong base board of wood about 5 feet long by 1 foot broad. Erected along one-half of this is a sort of stage, of sufficient height to raise the centre of the camera to a level with the tube of the microscope when in a horizontal position.

The camera, which should be of the "bellows" kind, capable of being drawn out to about 2 feet, and of such a size as to take plates of 6 inches square, is secured to this by means of binding screws. At the opposite extremity of the instrument is the mirror; this is about  $4\frac{1}{2}$  inches square, and is mounted, like an ordinary swing-glass, on a circular base-piece about 10 inches in diameter. This circular stand of the mirror is capable of being rotated round a pivot fixed in the base-board, and has its edge grooved. The part of the pivot that projects above the level of the stand, supports a couple of pulley sheaves.

On account of the length of the instrument, it is necessary that the mirror should be capable of being moved by strings from behind. These are arranged as follows. One endless band passes round the groove in the stand of the mirror, and through sheaves let into the back part of the stand for the camera. A second cord by which the mirror is moved on its horizontal axis is arranged thus. One end is fastened to the upper border of the mirror; it is next passed through one of the sheaves on the pivot; and is then carried back between the legs of the microscope to a grooved wheel about 2 inches in diameter, provided with a handle, fixed at the back of the instrument; a turn is made round this, and the cord brought back through the remaining sheave on the pivot to be fastened to the lower border of the mirror.

Between the mirror and the stand for the camera is a sort of tramway, the entire breadth of which should not be more than 8 inches. Sliding easily in this is the stand of the long-focussed condenser. This consists of two vertical wooden supports, across the top of which is a transverse piece with an opening into which



fits the condenser, the centre of which is elevated to such a height as to be opposite the tube of the microscope. Behind this lens the alum cell fits into a slit made to receive it in the upright pieces. Behind the condenser is a firmly sliding piece of wood, in which holes are cut to receive tightly the feet of the microscope.

The camera is connected with the microscope as follows. To the front of the camera is fixed a wide metal tube, which is connected to a somewhat smaller one by a joint of cloth.

This smaller tube ends in one which loosely fits the tube of the microscope, and which is lined with thick wash-leather in order to exclude all light.

Supposing then that one wishes to photograph any part of an object. The slide is fixed in position by means of the springs usually attached to the stage of the microscope, and its draw-tube pulled out. It is then inclined to a horizontal position, the mirror turned aside, and its feet fixed in the holes cut for their reception in the sliding piece which is then pushed back, so that the tube slips into the collar of the camera. The draw-tube is then replaced from the inside of the camera, the flange, with which it is generally provided, thus effectually shutting out any light that might otherwise enter. The alum cell which should contain a thickness of about half an inch should next be placed in the slit and filled with a concentrated solution of alum. The apparatus should then be placed across a table in front of an open window, out of which the mirror should be made to project so as to be out of shadows cast by the eaves, the base-board being so placed that the reflexion may take place at as acute an angle as possible. The window-blind should then be let down so that it hangs just above the condenser and turned as dark as possible, by which means the nuisance of a focussing cloth is avoided. Then seating oneself so as to be able to watch the focussing screen, the light is thrown on to the object, and the condenser focussed so as to throw a distinct image of the sun on the slide. After which the light is cut off by turning round the wheel of diaphragms preparatory to inserting the sensitized plate.

Here I would remark that it is a good plan to close all the holes in the diaphragm with pieces of nonactinic paper with the exception of one of moderate size, and to loosen the screw on which it pivots in order that it may turn as easily as possible.

Then having replaced the focussing screen by the dark slide and raised the shutter, the exposure is made by turning round the diaphragm wheel so that the opening in it may pass swiftly across the aperture in the stage; the shutter is then closed and the plate taken to the operating room for development.

Ground glass is rather too coarse a material for the focussing screen in micro-photography; for this purpose a piece of patent plate over which has been poured a film of mucilage of starch, or some

matt varnish, is better. The instrument may be used either in its simple or its compound form ; in other words, with or without the eye-piece.

When the eye-piece is not used, the camera must be drawn out to a great length to obtain sufficient amplification, whereas at 10 inches distance from the eye-piece one gets the full nominal power of the instrument.

On the whole, I prefer to use the eye-piece, though seldom at the full 10 inches.

Almost any good objective will give good results, but micro-photography is a very trying test to a glass.

A very essential quality is flatness of field ; should this be wanting, its absence will be painfully conspicuous in every impression taken. When the sun shines clearly, the most preferable process is the ordinary wet collodion, on account of its handiness and easiness ; but wet plates will not bear being kept for more than five or ten minutes before exposure, so that they are very inconvenient to use in cloudy weather when the sun shines out only occasionally between the clouds. On such occasions it is better to use dry plates, in the form of the gelatine-bromide process. They have the advantage too, that one may develop them at one's leisure, but require care in exposure, as they are more sensitive than ordinary collodion. The gelatine process which I use is that patented by Mr. Kennett, of Maddox Street.

By means of this process good micro-photographs may be obtained by the light of a paraffin lamp. When photographing at night by paraffin light or by the magnesium lamp, it is not necessary to use the long-focussed condenser ; the source of light being stationary, it is more advantageous to use an ordinary achromatic condenser, the mirror of the microscope being made use of as the reflector. The exposure with paraffin light is necessarily long—two minutes with low, and as much as fifteen with high powers. Representations of microscopic objects obtained by photography have this advantage over drawings, that it cannot be said that they show merely what the observer thinks he sees. Whatever is shown must be there, but on the other hand one plane of focus only can be represented, so that the sharp outlines of drawings must not be expected, especially in the case of the rounded bodies of which the majority of tissues are composed.—*Read before the Medical Microscopical Society, November 19, 1875.*

---

IV.—*Improved Method of Applying the Micro-spectroscopic Test for Blood-Stains.* By Jos. G. RICHARDSON, M.D., Attending Physician to the Presbyterian Hospital; Microscopist to the Pennsylvania Hospital.

THE value to medical jurisprudence of spectrum analysis as employed for the detection of dried blood is so fully established by the researches of H. G. Sorby, Dr. W. B. Herepath, Professor A. S. Taylor, W. Preyer, and others, that it seems unnecessary for me to do more than state that the demonstration of the two dark bands in the green caused by scarlet cruorine (hæmoglobin), such as that contained in a recent blood-stain, enables experts to discriminate positively blood from other red colouring matters soluble in water, whether mineral, vegetable, or animal, except an extract of the red feathers from the *Turacus albocristatus*, a bird found in the East Indies, and quite unknown on our continent of America.

Valuable as this test is thus seen to be, there are, unfortunately, several circumstances which limit its general application, as, for example, the changes in the constitution of hæmoglobin which occur from prolonged and frequently from comparatively brief exposure to the air, the modification of the absorption bands caused by the presence of other substances, and last, but not least in many instances, the difficulty of procuring sufficient material for experiment. The insuperable nature of this latter obstacle will be at once appreciated when I mention that whilst the smallest amount which Sorby, Herepath, and Taylor furnish directions for testing is a spot "one-tenth of an inch in diameter, or a quantity of the red colouring matter amounting to no more than one thousandth part of a grain," the important stain upon an axe-handle supposed to have been used in a murder I am now investigating probably weighed less than one three-thousandth of a grain when entire and uninjured.

The exigencies of this case have led me to seek out some other method than that of Mr. Sorby, who recommends that a solution of the suspected colouring matter should be made in a few drops of water contained in a cell composed of a piece of barometer-tube half an inch long and one-seventh of an inch in diameter. After numerous experiments, I contrived the following plan, which, on trial, proved satisfactory beyond my most sanguine expectations, enabling me to reveal the presence of blood in a quantity of matter only one one-hundredth the amount directed by Mr. Sorby.

Procure a glass slide, with a circular excavation in the middle, called by dealers a "concave centre," and moisten it around the edges of the cavity with a small drop of diluted glycerine. Thoroughly clean a thin glass cover about one-eighth of an inch larger than the excavation, lay it on white paper, and upon it place the tiniest visible fragment of a freshly-dried blood-clot (this fragment will

weigh from one twenty-five-thousandth to one fifty-thousandth of a grain). Then with a cataract-needle deposit on the centre of the cover, near your blood-spot, a drop of glycerine about the size of this period (.), and with a dry needle gently push the blood to the brink of your microscopic pond, so that it may be just moistened by the fluid. Finally, invert your slide upon the thin glass cover in such a manner that the glycerined edges of the cavity in the former may adhere to the margins of the latter, and, turning the slide face upwards, transfer it to the stage of the microscope.

By this method, it is obvious, we obtain an extremely minute quantity of strong solution of hæmoglobin, whose point of greatest density (generally in the centre of the clot) is readily found under a  $\frac{1}{4}$ -inch objective, and tested by the adjustment of the spectroscopic eye-piece. After a little practice it will be found quite possible to modify the bands by the addition of sulphuret of sodium solution, as advised by Preyer.

In order to compare the delicacy of my plan with that of Mr Sorby, a spot of blood one-tenth of an inch square may be made on a piece of white muslin, the threads of which average one hundred to the inch. When the stain is dry, ravel out one of the coloured threads and cut off and test a fragment as long as the diameter of the filament, which will of course be a particle of stained fabric measuring one one-hundredth of the minimum-sized piece directed by Mr. Sorby. When the drop of blood is old, a larger amount of material becomes requisite, and you may be obliged to moisten it with aqua ammoniæ, or with solution of tartrate of ammonium and protosulphate of iron; but in the criminal case referred to, *five months* after the murder, I am able from a scrap of stained muslin one-fiftieth of an inch square to obtain well-marked absorption bands, easily discriminated from those produced by a solution of alkanet-root with alum and those caused by infusion of cochineal with the same salt.

In cases of this kind, where the greatest possible economy or even parsimony of material is needful, I would advise the following mode of procedure for proving and corroborating your proof of the existence of blood, so that its presence in a stain may be affirmed with *absolute certainty*.

From a suspected blood-spot upon metal, wood, leather, paper, muslin, or cloth, scrape with a fine sharp knife two or three or more minute particles of the reddish substance, causing them to fall near the middle of a large thin glass cover. Apply in close proximity to them a very small drop of three-fourths per cent. salt solution,\* bring the particles of supposed blood-clot to its edge, and proceed as I have already directed.

\* See my paper "On the Value of High Powers in the Diagnosis of Blood-Stains," 'American Journal of the Medical Sciences,' July, 1874, p. 109.

After thus examining the spectrum of the substance, you may generally, by rotating the stage, cause the coloured fluid to partly drain away from the solid portion, wherein, under favourable circumstances, should the specimen be blood, the granular white blood-globules become plainly visible, as do also cell-walls of the red disks. Among the latter, if your mental and physical vision is keen enough, you can by the aid of a  $\frac{1}{2}$ th immersion lens and an eye-piece micrometer measure a series of corpuscles accurately enough to discriminate human blood from that of an ox, pig, horse, or sheep.

Lastly, to make assurance triply sure, lift up the thin glass cover, wipe off the tiny drop of blood solution and clot you have been examining on the folded edge of a thin piece of moistened blotting-paper, let fall upon it a little fresh tincture of guaiacum, and then a drop of ozonized ether, which will at once strike the deep blue colour of the guaiacum test for blood.

In this way I have actually obtained these three kinds of evidence, to wit, that of spectrum analysis, that of the microscope, and that of chemical reaction, from one single particle of blood, which, judged by a definite standard,\* certainly weighed less than one fifteen-thousandth, and probably less than one twenty-five-thousandth, of a grain.

Although Mr. Sorby claims to be able to demonstrate the absorption bands from a single red blood-corpuscle, yet, as his instructions for detecting *blood-stains*, quoted above from the 'Quarterly Journal of Science,' vol. ii. p. 198, are reiterated in his paper in the 'Monthly Microscopical Journal' of July 1871, p. 9, and seem to be those solely relied upon by Dr. Herepath, in the 'Chemical News,' 1868, vol. i. p. 124, by Prof. L. S. Beale, in his 'How to Work with the Microscope,' London, 1868, p. 222, by Dr. W. B. Carpenter, in 'The Microscope and its Revelations,' 5th ed., London, 1875, p. 121, and by Prof. A. S. Taylor, in Guy's Hospital Reports, 1869, p. 274, and in his 'Principles and Practice of Medical Jurisprudence,' 1873, vol. i. p. 542, and since W. Preyer † advises no more delicate mode than making and examining a solution in a watch-glass, I feel justified in offering my method to microscopists and medical jurists, as an improvement in the ordinary and facile application of spectrum analysis to blood-stains, by which this important test is rendered at least one hundred times as delicate as it has hitherto been when employed according to the directions of the highest British or Continental authorities, thus enabling us to detect a recent blood-spot on white muslin covering one ten-thousandth of a square inch and forming a speck scarcely visible to the unassisted eye.—*Read before the Biological and Microscopical Section of the Academy of Natural Sciences, Philadelphia, U.S.A.*

\* See 'Handbook of Medical Microscopy,' Phila., 1871, p. 283.

† 'Die Blutkrystalle,' Jena, 1871, s. 114.

## PROGRESS OF MICROSCOPICAL SCIENCE.

*The Spermatozoa of Petromyzon.*—Mr. George Gulliver, F.R.S., says: \* "In my paper 'On certain Points in the Anatomy and Economy of the Lampreys,' published in 1870,† there is an engraving of the spermatozoa of *Petromyzon planeri*. But I know not that those of *P. marinus* have ever been described or depicted; and they differ curiously in the two species. The spermatozoa of *P. marinus*, notwithstanding the great size of the species, are much the smallest, and have a distinct and rounded head. Their mean length is about  $\frac{1}{4000}$  inch, and their thickness  $\frac{1}{8000}$ . They were obtained from a fish thirty-two inches in length and three pounds in weight, taken on May 12, 1874, in the river Stour, near Sturry Mill, about two miles below Canterbury. The milt, which distended the whole abdomen from the pericardium to the anus, was a soft pulpy mass chiefly composed of a creamy semen, and so rich in and crowded with spermatozoa of such minuteness that they were with difficulty distinguishable; and it was not before the semen had been much diluted and placed under Powell and Lealand's  $\frac{1}{8}$ th objective that a good view of them was obtained. Under a lower power, especially in the pure semen, nothing more than congeries of indistinct rounded points appeared, like those which I have described in the 'Proceedings' of this Society ‡ as the 'molecules of the semen.' In short, unless great care be taken, the spermatozoa in the ripe testis are so very faint, minute, and abundant, that they are likely to escape detection. But the spermatozoa of the little *Petromyzon planeri* are much larger and more easily seen. They are club-shaped, without a distinct head, and have an average length of  $\frac{1}{3000}$  inch, and a thickness of  $\frac{1}{3000}$ . They were obtained in April from a fish six inches in length and two drachms in weight. Further details concerning the generative organs of both sexes are given in the paper first quoted in the present communication."

*The Leaf Glands of Saxifraga tridactylites.*—An addition to our list of carnivorous plants is suggested by Mr. J. C. Druce in a letter to the 'Pharmaceutical Journal,' in a little early spring flower found chiefly on the tops of walls, *Saxifraga tridactylites*, a plant not very distantly allied to the Droseras. Mr. Druce states that when examined under the microscope the leaves are seen to be covered with glands of a similar character which exude a viscid secretion, in which he found a midge was entrapped and held fast when placed on the leaf. On examining a number of leaves, he found in all of them the débris of insects which had apparently perished in this manner.

*Presence of Micrococcus and Bacteria in the Walls of Hospital Wards.*—The analyses of the air, and other experiments made by Pasteur, for the purpose of investigating the doctrine of spontaneous generation, have demonstrated that the germs of inferior organisms—micrococci, bacteriæ, &c.—are everywhere present in the air. In

\* 'Proceedings of the Zoological Society.'

† Ibid., 1870, p. 844.

‡ Ibid., 1842, p. 99.



a hospital the air contains a greater number of these elements, and in addition certain special bodies, such as pus-globules, spores of epiphytic parasites, which emanate from diseased organisms, and, owing to their volatility after desiccation, are susceptible of hovering in the atmosphere. In 1865, M. Broca discovered pus-globules in the liquid expressed from the sponge with which the walls of one of the wards of the St. Antonio Hospital had been washed. In 1860, M. Chalvet was inclined to attribute the blue coloration which is often observed in the vicinity of wounds to the presence of microscopic algæ of the species *Palmella*. In 1861, Dr. Eiselt, of Prague, placed an instrument, analogous to the aëroscope of Pouchet, between two beds, in a ward occupied by thirty-three children with purulent ophthalmia; the apparatus consisted of a glass plate coated with glycerine, and pus-globules were distinctly seen. To the above and analogous facts, which are recorded in the dissertation of Dr. Deville (Strasbourg, 1860), are to be added the recent experiments of Dr. Nepven, of Paris: One square metre of wall in the surgical ward of La Pitié having been washed after neglect for two years, the liquid expressed from the sponge (about thirty grammes) was examined immediately afterward. It was black, and showed micrococcus in large amount, several bacteria, epithelial cells in small number, several pus-globules, several red globules, and, lastly, irregular, blackish masses and ovoid bodies of unknown nature. The experiment was conducted with all possible precautions.

*Bacteria found in the Perspiration of Man.*—Dr. Eberth, of Zürich,\* has, says the 'Medical Record,' found, by aid of the microscope, in the sweat from the face, some corpuscles which he considered as bacteria. This view became confirmed when he examined the axilla, breast, and inner side of the thigh of several persons in a state of perspiration. The sweat of these parts contained nearly always enormous numbers of bacteria. In most cases they originated from minute bodies found upon the hairs in the mentioned regions, forming little nodules on them, and giving them a greyish or a brick colour. They were recognized by the author as accumulations of micrococci. They may rapidly increase in number, are smaller than the diphtherial micrococci, and are nearly indifferent to reagents (concentrated acids, alkalis, alcohol, ether, chloroform). Iodine colours them yellow. The vegetation of bacteria on the hairs may be observed in cases where they are changed already, beginning in places which have clefts between their cells. The vegetation occupies large spaces, especially in the direction of the longest diameter of the hair. Dr. Eberth observed a mycelium and micrococci, and thinks that the latter are the fruits of the former. Other investigators observed coloured sweat, red and blue, which contained micrococci. It was difficult to decide in these cases if the colouring matter was adherent to the micrococci, or if it was a product of the vegetation.

*The Migrations of the White Corpuscles.*—The 'Medical Record' says that Dr. Jul. Arnold, of Heidelberg † has examined the con-

\* Virchow's 'Archiv,' vol. lxii.

† Ibid.

ditions under which red blood-corpuscles emigrate, and the question arose whether the white blood-corpuscles leave the walls of the vessels in the same manner, or whether they penetrate the epithelial plates themselves. To decide this question, he examined the mesentery, the tongue and the bladder of the *rana temporaria* and the *rana esculenta*, and found that generally the white corpuscles leave the vessels by means of stigmata. The irritation of the organs was caused in different ways. Thus, the mesentery was exposed for a few hours to the atmosphere, while the tongue was injured and the bladder was injected by a weak solution of nitrate of silver. Infusions of cinnabar into the blood were also made with the view to colour the white blood-corpuscles. Twenty-four hours after the operation the animals were bled to death, and then the circulatory system was injected from the aortic bulb by a solution of nitrate of silver from  $\frac{1}{2000}$  to  $\frac{1}{3000}$ . The examination of the preparation took place immediately in a three-fourths per cent. solution of chloride of soda, or after colouring with carmine in glycerine. The white corpuscles could be observed in numerous phases of emigration. The transmigration always took place at certain points (stigmata). Had the process of emigration been stopped in time, the emigrated blood-corpuscles were to be seen in the sheath of vessels, or at a short distance from this. The form of the white corpuscles is elongated in the state of escape. Many of them have prolongations, fixed in the stigmata. Sometimes numbers of white corpuscles accumulate on the outer wall of the vessels, so that the lining epithelial membrane appears to be separated from the sheath of the vessel. The author never observed that the plates themselves were penetrated by the white corpuscles. As a result of the disturbance in circulation, combined with the emigration of white blood-corpuscles, it was found that the borders of the cells forming the vessels are not so distinct as in a normal state. Between them are a greater number of dark spots (stigmata) than in a normal state, generally not so large that red blood-corpuscles could pass them. Dr. Arnold observed that granules of cinnabar, as well as colloid substances, may leave the vessels through the stigmata. The cause of the easier penetrability of the vessels may be found in an alteration of the condition of the cement connecting their cells. A great number of the emigrated white corpuscles are carried off by the lymph-vessels. The author thinks that with the disturbance in circulation during emigration there are connected currents directed towards the walls of the vessels, and that they are of different strength.

*The supposed Renal Organ in Crustacea.*—Mr. A. S. Packard, jun., in a recent paper says, that in dissecting the king crab one's attention is directed to a large and apparently important gland, conspicuous from its bright red colour contrasting with the dark masses of the liver and the yellowish ovary or greenish testes, and presenting the same appearance in either sex. "The glands are bilaterally symmetrical, one situated on each side of the stomach and beginning of the intestine, and each entirely separate from its fellow. One of these glands consists of a stolon-like mass, running along close to the great col-



lective vein, and attached to it by irregular bands of connective tissue, which also holds the gland in place. From this horizontal mass, four vertical branches arise, and lie between and next to the partitions at the base of the legs, dividing the sides of the body into compartments. The posterior of these four vertical lobes accompanies the middle hepatic vein from its origin from the great collective vein, and is sent off opposite the insertion of the fifth pair of feet. Half-way between the origin of the vein and the articulation of the foot to the body, it turns at a right angle, the ends of the two other lobes passing a little beyond it, and ends in a blind sac, less vertical than the others, slightly ascending at the end, which lies just above the insertion of the second pair of feet. The two middle lobes are directed to the collective vein. Each lobe is flattened out somewhat and lies close to the posterior wall of the compartment in which it is situated, as if wedged in between the wall, and the muscles between it and the anterior portion of the compartment. Each lobe also accompanies the bases of the first four tegumentary nerves. I could not by injection of the gland, make out any general opening\* into the cavity of the body or any connection with the hepatic or great collective vein; any attempts to inject the gland from the veins failing. The four lobes certainly end in blind sacs. The lobes are irregular in form, appearing as if twisted and knotted, and with sheets and bands of connective tissue forming the sheaths of the muscles among which the gland lies. Each lobe, when cut across, is oval, with a yellowish interior and a small central cavity, forming, evidently, an excretory duct. The gland externally is of a bright brick red. The glandular mass is quite dense, though yielding. It is singular that this conspicuous gland, though it must have engaged their attention, has not been noticed by Van der Hoeven, Owen, or A. Milne-Edwards in their accounts of dissections of this animal. When examined under a Hartnack's No. 9 immersion lens and Zentmayer's B eye-piece, the reddish external cortical portion consists of closely aggregated irregularly rounded nucleated cells of quite unequal size, and scattered about in the interstices between the cells are dark reddish masses which give colour to the gland. They are very irregular in size and form, and twenty hours after a portion of the parenchyma was submitted to microscopic examination vibrated to and fro. I am reminded in the vibrating movements of these bodies, of Siebold's † description of similar bodies in the renal organs of the Lamellibranchs, i. e. the gland of Bojanus. He says in a footnote, p. 214, ‡ 'If the walls of these organs are prepared in any way for microscopic examination, a part of their parenchyma separates into a vesiculo-granular mass, the particles of which have a very lively dancing motion. The motions are due to portions of ciliated epithelium adhering to the cells and granules.'

"In other portions of the outer reddish part of the gland, where

\* Leydig ('Naturgeschichte der Daphniden') states that several anatomists, after laborious attempts, have failed to find the opening to the green gland in any crustacean.

† 'Anatomy of the Invertebrates.'

‡ Burnett's Translation.

the pigment (?) masses are wanting, the mass is made up of fine granular cells, not nucleated. Other cells have a large nucleus filled with granules and containing nucleoli."

¶. "In the yellowish, or, as we may for convenience call it, the medullary portion, are scattered about very sparingly what are probably the round secreting cells. The nucleus is very large and amber coloured, with a clear nucleolus; others have no nucleolus, and the small ones are colourless."

"I am at a loss to think what this gland with its active secreting cells, filled with a yellowish fluid, can be, unless it is renal in its nature. This view is borne out by the fact of its relation with the hepatic and great collective vein. If future examination shows some outlet into the venous circulation, then its renal nature would seem most probable. No other organ that can be renal in its nature exists in *Limulus*. In its general position and relations it is probably homologous with the green gland of the Decapod Crustacea, and its homologue in the lower orders of Crustacea, which is supposed also to be renal in its nature. It may also possibly represent the organ of Bojanus in the Mollusca, which is said to be renal in its function. It perhaps represents the glandular portion of the segmental organs in worms. That so large and important a gland is an embryonic gland, in adult life aborted and disused, is not probable, nor is there any good reason for regarding it as analogous to the suprarenal capsule of the vertebrates, analogues of which are said by Leydig to exist in *Paludina* and *Pontobdella*."

"Reasoning from their histological structure, and by exclusion, it seems not improbable that these glands are renal in their nature and homologous with the green glands of the normal Crustacea."

"They seem also homologous with the organs described by M. A. Giard in the *Rhizocephala*, and said by him to be 'situated on each side of the middle part of the animal, and generally coloured yellow or red (primitive kidneys?).' \*"

"I may add that all these observations were made on living *Limulus Polyphemus*, in the laboratory of the Anderson School of Natural History at Penikese Island, Mass."

## NOTES AND MEMORANDA.

**Browning's Platyscopic Lens.**—Mr. J. Browning has recently produced a form of pocket lens, which he has called the *platyscopic*, and which certainly for extreme flatness of field is superior to the Codrington or any other lens that we have seen. We have given it careful trial ere expressing our opinion, and we consider that while lower in power it possesses advantages which make it, *par excellence*, the first in the field. It is a triple achromatic combination, in which

\* 'Annals and Mag. N. H.,' Nov. 1874, p. 388.

the chromatic and spherical aberrations are corrected by the central lens of dense flint. This lens is nearly three times as thick as the crown-glass lenses. The interior curves are almost hemispheres. The final correction for spherical aberration is made by altering the thickness of the dense flint-glass lens. The three lenses are united by a transparent cement which has a refractive index corresponding very nearly with the glass. This prevents light being lost by reflexion from the surface of the deep curves. High-power Stanhope or Codrington lenses are only suitable for the examination of transparent objects. The Platyscopic Lens focusses about three times as far from the object as the Stanhope or Codrington lenses. This allows opaque objects to be examined easily, as light can be conveniently allowed to fall upon them at any required angle.

**Lactate of Silver as a Colouring Agent.**—It seems that M. Alferow\* advocates the use of the lactate of silver instead of the nitrate. He recommends a solution of one part in eight hundred of distilled water, with the addition of a few drops of a concentrated solution of lactic acid. The presence of the free acid renders precipitation less easy, and the only formations that occur are the chloride and albuminate of silver. The formation of several disturbing precipitates is thus avoided. Alferow asserts that the pictures are much clearer than those obtained by the nitrate, and that the lactate, if applied to the mesentery of the living frog, interferes less with the circulation. It may be mentioned that this author denies the existence of stomata in blood-vessels and serous membranes, and states that solid particles traverse epithelial layers between the cells, which move to give them passage by some mechanism not yet understood.

**Silica Films and the Structure of Diatoms.**—Mr. G. W. Morehouse has been following out the line of investigations begun some time ago by our Secretary, Mr. H. J. Slack. In a paper read before the Memphis (U.S.A.) Microscopical Society, at one of its summer meetings, the writer remarked that he had prepared some films of silica, after the process described by Mr. H. J. Slack.† “To facilitate examination, some of the films were carefully washed and then mounted in balsam; others were burned out upon the glass cover before mounting. The latter method is much the best and quickest. The opinion of so distinguished an observer as Mr. Slack is entitled to great weight, and the writer is happy to be able to concur with him in the opinion that the cellular character of some of the films is due to bubbles of gas; and that, under the conditions to which these experiments are necessarily confined, the deposition of the silica is generally in the form of spherules. No one pretends that these conditions approximate to those that obtain in the growth of the protective covering of the living diatom; yet, in a kind of unexplained general way, the experiments upon these artificial films are supposed by some to strengthen the ‘bead theory,’ although the conditions

\* ‘Archives de Physiologie,’ Nos. 4 and 5, 1874.

† ‘Monthly Microscopical Journal,’ June 1, 1874, p. 238.

under which the spherules are formed probably differ as decidedly from those surrounding the growth of the diatom, as does the manufacture of shot from a natural formation of lead. As has been shown by Mr. Slack, a very slight change in the conditions of the experiments is often followed by a difference in the character of the films produced." After some further observations the writer advances to describe the different preparations of diatoms examined by him :

*Coscinodiscus oculus iridis.* Best illumination, at a north window, from white clouds. The specimen very large, and the two plates separated. The inside layer perforated with circular openings; no film detected. The plate is thickest on the border of the openings, and the hexagonal network of the outside plate lies in the depressions between and everywhere around these thickenings of the inside plate. The outside plate is furnished with a thin film over each hexagonal areola, with a fine angular branching network extending out from the coarse hexagonal ridges into the films to strengthen them, and is coarsest nearest the ridges, and is very fine, or, in some cases, entirely diaphanous in the central parts of the areolæ. The film is seen perfectly along the line of fracture, which always passes through the depressions. The thick portion next the holes, in the inside plate described above, occasionally extends beyond the line of fracture, owing to its greater strength. Distinct shadows of the sides of the hexagons are observed as the mirror is thrown to one side or the other.\*

*Aulacodiscus Samøensis.* Structure the same as *Coscinodiscus*.

*Terpinæ Americana* and *T. musica.* The structure of both the same. A distinct angular open network, porous almost like a sponge. As the objective is lowered the outside markings gradually become indistinct, as the lower and finer ones of the same general character come into focus.

*Epithemia Hyndmannii, S.* and *E. turgida.* An outside plate with hexagonal depressions and network, strengthened by internal transverse ribs. It breaks through the depressions and leaves well-marked projecting points.

*Campylodiscus.* The various species of this genus are seen with perforated plates and the line of fracture running through the holes.

*Trinacria regina.* Perforated plate, with fracture through the holes.

*Cymbella.* Very large members of this genus, observed in hundreds of specimens, with structure resembling grating, and fracturing through the depressions, leaving the points of the grating distinctly projecting.

*Gomphonema geminatum.* This shell is very instructive, for the ribs radiate and branch, diminishing in strength toward the margin in the best way to make the shell strong and light. The line of fracture runs through the so-called beads in any direction.

*Stauroneis Stodderii.* A peculiarly and very strongly marked shell.

\* Compare with the careful and very accurate observations of Mr. J. W. Stephenson, 'Monthly Microscopical Journal,' vol. x., p. 1.

It has coarse longitudinal ridges and furrows, and, it seems, slightly radiating transverse ridges passing over and across the longitudinal ones and through the furrows.

**Erratum in Professor Abbe's Paper.**—Owing to a printer's error, the word *sum* in the 19th line of p. 193 in the October number has been placed instead of *sine*, which it should have been. The word *sum* in the preceding line is a mere surplusage. We may state also that Dr. Fripp had nothing to do with either the reduction or reproduction of the article in these pages.

---

## CORRESPONDENCE.

---

### RESOLUTION OF *AMPHIPLEURA PELLUCIDA*.

*To the Editor of the 'Monthly Microscopical Journal.'*

WAYLAND, N.Y., October 23, 1875.

SIR,—That *Amphipleura pellucida* is "dotted" or "beaded" can no longer be doubted. It was so seen by Mr. J. Edwards Smith, of Ashtabula, Ohio, and the observations published in the 'Lens' (Chicago) for April, 1873. The objective used was a Tolles'  $\frac{1}{10}$ th. I had at nearly the same time, and independently, reached the same result with a Tolles'  $\frac{1}{8}$ th immersion (see 'American Naturalist' for May, 1873). In the 'Boston Journal of Chemistry' for June, 1875, Samuel Wells, Esq., of Boston, confirms these observations, using a Powell and Lealand  $\frac{1}{8}$ th and a Tolles'  $\frac{1}{4}$ th and  $\frac{1}{10}$ th. And now Messrs. Dallinger and Drysdale, in the 'Monthly Microscopical Journal' for September, 1875, announce the same result, obtained with a Powell and Lealand  $\frac{1}{4}$ th. Witnesses enough.

A word as to objectives of medium angle of aperture. Some microscopists seem to have the impression, both in England (recent discussions in this Journal) and in America ('Popular Science Monthly,' New York, November, 1875), that such glasses, of good quality, can only be obtained from Germany and France. But the principal makers of England and America can make, and some of them, at least, have been making this class of objectives when required, of proportionate merit with their higher-angle immersion lenses. Recognizing the fact that no one glass can be adapted to all grades of work, they undertake to meet the requirements of those interested in any department of microscopic study. As a case in point, I have a Tolles'  $\frac{1}{4}$ th inch, dry, of 70° angle of aperture, with cover adjustment, costing \$26.00 U. S. currency. After allowing for depreciation of paper currency, this is about 4l. 12s. (In comparing prices with those of foreign makers, duty, exchange, &c., would be considered.) This lens has a tapering front, permitting the use of a bull's-eye condenser on opaque objects, and has sufficient

working distance to resolve the *Pleurosigma angulatum*, through a thick slide turned over. With the slides right side up, and rising up to  $\frac{1}{4}$ -inch eye-piece,  $\times 1600$ , I resolve the *angulatum* either dry or in balsam, and show both sets of lines of *Navicula rhomboides* distinctly. *Stauroneis phœnicenteron* is resolved without resorting to oblique light. On *Surirella gemma* I get the transverse lines strong, but the longitudinal are faint and unsatisfactory to one accustomed to the complete resolution into hexagons got by objectives of higher angle. On the whole, it is a very useful glass, but cannot take the place of the immersion objectives of high angle on one side, nor of  $\frac{1}{4}$ -inch to  $\frac{3}{8}$ -inch objectives on the other.

The above work with the  $\frac{1}{4}$ th was all done without the aid of Mr. Wenham's Reflex Illuminator,—a very important aid in resolving lined tests, whether used as originally intended by the inventor, on dry mounts, with object in contact with the slide; or, as pointed out by Samuel Wells, Esq., on balsam slides, with objectives of sufficiently high angle of aperture to give a bright field. The latter method, to me, is the most serviceable of the two, for on most of my slides the objects adhere to the cover. Out of half-a-dozen slides of *S. gemma*, I was unable to find a single frustule detached. The Reflex Illuminator makes the medium angles approach more nearly to the former performance of the higher, but it also enables the latter to fully maintain their superiority over the former.

Yours truly,

GEO. W. MOREHOUSE,

Wayland Depôt, Steuben Co., New York, U.S.A.

#### MR. HICKIE AND PROFESSOR HASERT'S NEWEST OBJECTIVE.

To the Editor of the 'Monthly Microscopical Journal.'

LIVERPOOL, November 5, 1875.

SIR,—I was very anxious to hear further respecting Professor Hasert's newest objective, having received from a friend in London a report of what had taken place at the October meeting of the Royal Microscopical Society respecting the above objective, and I must confess that I felt very much disappointed when I read Mr. Hickie's letter in your November number, and still more so when I heard that the objective was not exhibited, as suggested, at the November meeting of your Society; possibly Mr. Hickie may not be guilty of this mishap.

It is, however, curious that after so much fuss has been made of Hasert's objective, when the time came for proofs the objective was not produced!! Mr. Hickie's letters are very interesting because they generally contain some outlandish disclosures, such as, "Its performance (No. 7, Benèché's) on *S. gemma* I shall leave unrecorded, as the truth here would seem incredible."\*

\* 'M. M. J.,' No. lxx., p. 208.

"But with regard to *S. gemma* itself, I attach no sort of value to this diatom; and I have often wondered how such a thing ever got voted into a test."\*

"Of course I used no condenser. I have always regarded that article, *when employed on high-power delicate tests*, as a mere optician's booby-trap. Its only use there is to disguise the optician's faulty workmanship and to make a bad glass pass muster for a good one."†

"Indeed, I seem to myself never to have known what the word definition really meant till I saw this glass (Hasert's), so beautifully clear, sharp, and distinct were all the details. I certainly never saw any objective that even approached it!"‡

After extracting the above from Mr. Hickie's correspondence, I do not think it necessary to trouble your readers with any comments on Mr. Hickie's statements, but I may just be permitted to add that, although I do not doubt for a moment that Mr. Hickie may be a very good mathematician, a very accurate draughtsman, or an excellent German scholar, I do not consider his skill as a manipulator of high powers to be such as he wishes the microscopical world to believe; and when next in London, Mr. Hickie will, perhaps, display before the Royal Microscopical Society some of his extraordinary feats of manipulative skill, giving thus a proof which will certainly be much more convincing than the reports of Mr. H. P. Steadman § and Mr. J. R. Leifchild. ||

As to Mr. Leifchild, I know him personally: he may be a good geologist, mathematician, or anything else, but as a judge of the performance of high powers and of the resolution of difficult tests, I can only say that I very much doubt whether he has ever worked with an objective of less than half an inch focal length, or resolved *P. formosum*!!

I have just heard from an authority who saw the celebrated Hasert's objective, in London, that its performance is *nothing* like what it is reported to be; and it appears to me that we, as Englishmen, ought to be more careful in setting afloat reports which, when once spread, will certainly damage the credit of the makers of the *finest* object-glasses in the world—the English.

Some time since Mr. Hickie caused a similarly startling sensation with Benèché's improved No. 7 objective, and the *straight candle-light*. I have seen *three* of these improved objectives and compared them with similar powers by Beck, Hartnack, Powell and Lealand, and Ross—the result being always that Benèché's objectives were found "*moderately bad*," and would not accomplish the feats announced by Mr. Hickie, not only in my hands but also in those of some well-known microscopists; this bad or inferior performance may have been caused either by our lacking Mr. Hickie's extraordinary manipulative skill—or, rather, by the inferior quality of Benèché's objectives.

\* 'M. M. J.' No. lxxii., p. 290; vide also No. lxxvi., p. 175 (Mr. Leifchild's letter).

† Ibid., No. lxxix., p. 33.

§ Ibid., No. lxxii., p. 291.

‡ Ibid., No. lxxxiii., p. 263.

|| Ibid., No. lxxvi., p. 175.



Mr. Hickie does not seem to believe in anything else but German objectives. I very much doubt if he has ever looked through some of the fine Powell and Lealand's objectives (we know he does not approve of their eye-pieces), above all those made on their *new formula* ? ! !

What feats would Mr. Hickie accomplish should he use Powell and Lealand's *finest* objectives, and their achromatic condenser ?

Perhaps he might succeed in superseding the performance of his German object-glasses, and his straight candle-light, and favour us with some more of his startling discoveries ! ! !

I am, Sir, your obedient servant,

M. J. GORDON.

### PROFESSOR HASERT'S NEW OBJECTIVE.

*To the Editor of the 'Monthly Microscopical Journal.'*

19, MONTPELIER PLACE, BRIGHTON, November 10, 1875.

SIR,—Your readers will peruse with interest Mr. Hickie's report on the glass above referred to.

Whatever else it may do, this new glass seems calculated to cause a reconsideration of some views very generally current. For instance, Mr. Hickie, speaking of its definition, gives it his unqualified admiration; and says, "I seem to myself never to have known what the word definition really meant till I saw this glass, so beautifully clear, sharp, and distinct were all the details. I certainly never saw any objective that even approached it."

And yet it appears that the lens will not bear deep eye-piecing! Indeed its conduct in this respect, according to Mr. Hickie's account, though not in his words, is nothing less than very bad.

But if there is one thoroughly accepted idea connected with lenses, it is that deep eye-piecing is, above all, the surest test of their correction. So that we have here a contradiction. Mr. Hickie explains by saying that he "came to the conclusion that there is ample room for improvement in our eye-pieces." No doubt; but whatever their demerits, they are as fair a test for one lens as for another of like power; and the fact remains that this Hasert objective, though it defines with extraordinary precision, bears deep eye-pieces much worse than the general run of glasses.

The facts relating to the screw-collar are very remarkable; but under the circumstances, I cannot think with Mr. Hickie that the absence of that apparatus will be an insuperable objection in England; besides, if these glasses are really good enough to induce English opticians to make them, they will no doubt be furnished with screw-collars, to meet extreme cases; a great advantage, though everybody will appreciate the comfort of not being ordinarily obliged to use them.

On the subject of penetration, working histologists will be very disappointed in the vagueness of Mr. Hickie's report; hence I beg

permission to ask him for information as to what tissues were examined, their thickness, how prepared, in what media mounted, what structures were seen in them, how defined, and to what depth were they well seen?

If Mr. Hickie will be so good as to inform us upon these points, and any others that may occur to him, I am sure he will confer a favour upon all who, like myself, are looking forward anxiously to improvements in physiological glasses.

I am, Sir, faithfully yours,

R. BRANWELL.

### A NEW SECTION BLADE.

To the Editor of the 'Monthly Microscopical Journal.'

BALTIMORE, MD., November 14, 1875.

SIR,—The qualities required in a section useful for microscopic research are even thinness pushed as far as tissue structure demands, and smooth surfaces, the production of a perfect knife edge. This last is urged forward in slicing fashion, whether a holder be employed or not; but in all cases personal equation varies or jeopardizes the result, and the student's end can be attained then only when this element of failure or inconstancy shall have been minimized.

Wherefore it occurred to me to have recourse to an *eccentric* knife, and I devised in the month of June last the blade which I employ. It resembles the chisel of a plane, but its edge forms the arc of a circle of  $2\frac{3}{4}$  inches radius, of which the centre is above and to the left of the axis of revolution; consequently it works *eccentrically* in a sweeping course, whether it be used directly upon the glass table of the holder, or lifted from it by a very thin polished steel washer.

The dimensions are as follow: thickness  $\frac{1}{8}$  inch, width  $2\frac{1}{4}$  inches, length  $3\frac{1}{4}$  inches. It is flat beneath, but is ground away above to a thin edge on the cutting side, and on the upper surface is a removable button for grinding. Below the centre of the arc of the cutting edge is the *eccentric* hole through which passes the pin that also perforates the glass table of the holder, and upon which it revolves. When the blade is in place, a small washer and a short open spring are to be slid on the pivot over it, and lastly a screw with a milled head to make all tight. Now by withdrawing the knife to the left, the lower edge just clears the margin of the aperture for paraffin, but as the blade descends to the right, its edge traverses the whole of the aperture, with which its construction corresponds.

With this arrangement it is easy to flood the object under treatment.

I have also used a *very thin* steel washer,  $1\frac{3}{8}$  inch radius, *under* the blade, so that its cutting side can never be dulled by *débris* upon the glass plate.

The aperture of the cylinder in the holder is seven-eighths of

an inch, which is traversed by the moving knife from heel to point, and with so gentle a sway that perfect sections are readily made.

With this microtome I have produced sections as large as the cylinder would allow, especially of nerve matter; but it answers just as well for other tissues if *properly prepared* for cutting, an indispensable condition.

CHRISTOPHER JOHNSTON, M.D.

### CHROMATIC AND SPHERICAL ABERRATION DISTINCT.

*To the Editor of the 'Monthly Microscopical Journal.'*

16, FITZBOY SQUARE, W., November 20, 1875.

SIR,—I fail to perceive what benefit can result to science from an endeavour to confound two things known by distinct characteristics, and designated by different terms: it tends (as it appears to me) to meddle with, and muddle, rather than to elucidate scientific nomenclature. I allude to a paper in your last issue by Dr. Royston-Pigott, "On the Identical Characters of Chromatic and Spherical Aberration." Aberration is I take it—as its derivation implies—"a straying away from." Spherical aberration is a straying away from the focus of rays not very near the axis of the pencil reflected, or of *homogeneous* rays refracted, at a spherical surface; and chromatic aberration is the straying away of all other rays from the focus of rays of any given colour, in consequence of their unequal refrangibility.

Dr. Pigott states that the spherical aberration of a homogeneous pencil "is for convenience called chromatic aberration:" to this statement I must entirely demur. In the succeeding paragraph he is startled by the statement that all chromatic aberration does not involve spherical aberration. In a lens with proper elliptic surfaces (if it could be constructed) there would be chromatic but no spherical aberration; and Sir J. Herschel (I think) has given a formula by which the spherical aberration of a lens may be corrected by a meniscus of the same glass, but the chromatic aberration would thereby be much increased.

It is perfectly true that in all lenses chromatic and spherical aberrations must be coexistent, because the only practicable surfaces are spherical; but coexistence and identity are not synonymous terms.

I remain, Sir, yours faithfully,

CHARLES BROOKE.

### CHROMATIC AND SPHERICAL ABERRATION.

*To the Editor of the 'Monthly Microscopical Journal.'*

SIR,—I have made so many attacks against Dr. Pigott's strange optical announcements—for such I have considered them—that I had determined to allow his paper—the strangest of them all—concerning chromatic and spherical aberration to rest without comment, as its erroneous teaching must be evident to everyone whose instruction is

intended. Mr. Hogg having called notice to the article, I venture to remark that chromatic and spherical aberrations are quite distinct in their characters. It is well known to practical opticians that a telescope lens can be corrected for colour, leaving nothing but the effects of irrationality, and yet require all the curves to be remodelled, in order to correct spherical aberration only; and a telescope when so corrected has the front and posterior surfaces of the object-glass of different radii: If the lenses of the object-glass are reversed in the cell, all fine definition becomes lost.

According to Dr. Pigott's theory, so long as achromatism is obtained ANY form of lens will suffice; but we are far from realizing this felicitous state of things. Photographic lenses must now be made to work visually with perfect telescopic distinctness, in order to meet the requirements of photographers. But as the chemical plane of distinctness is within the visual focus, the lenses have to be very much under-corrected, and the sharpness of picture is obtained or the *spherical* aberration corrected, entirely by the curvatures given to the combination.

I am, Sir, yours obediently,

F. H. WENHAM.

#### THE REFLEX ILLUMINATOR.

*To the Editor of the 'Monthly Microscopical Journal.'*

SIR,—As you have properly intimated that your pages must now be closed against any further discussion with Mr. Stodder in relation to his objectives, therefore beyond what I have already recorded I shall make no remarks.

But, as Mr. Stodder asks me a question in his second letter, I ask permission to reply. When I stated, "water between the front lens," I appear to have omitted the words *and cover*. All light being thrown on top surface of slide, at an internal angle beyond that of total reflexion, the field is quite dark with objectives of the largest aperture—not the most extreme rays of which can admit them. All transparent objects adherent to the total reflecting surface, cause the rays to enter—without perhaps much deviation—and the object being irregular in surface, or internal structure, the light is arrested and dispersed, and the minute parts rendered visible with a dark field.

If the object is mounted in Canada balsam, no such condition exists, as the top of the *cover* then becomes the total reflecting surface. If the objective is now used as an immersion, there will be no reflexion from the cover, for the light now enters the object-glass. But if the object is mounted dry, and lays on the *slide*, then the object-glass may be used as an immersion, with a dark field, because the cover in fact becomes nothing more than an additional thickness of front lens, and acts optically as part of it.

I am, Sir, yours obediently,

F. H. WENHAM.

## MR. MAYALL'S LETTER.

To the Editor of the 'Monthly Microscopical Journal.'

SIR,—I have no intention of discussing optical questions with Mr. Mayall. My paper referred to (which he so genteelly denies), demonstrating a means of obtaining full apertures on immersed objects, was contributed by me to the 'Quarterly Journal of Microscopical Science,' No. 12, July 1855, page 302. It did treat only of immersed apertures, under the title "On the Aperture of Object-glasses in relation to Objects in Canada Balsam."

In expressing his dissent against an article that he has not read, and saying that it has "no reference to the subject," Mr. Mayall commits himself to a mere blind and senseless contradiction.

The cube of glass with which my "simple demonstration" is tried measures three inches and one-tenth square. If an object-glass, say a  $\frac{1}{15}$ th, is *adjusted for immersion* and focussed on to surface, the disk of light observed, and then water introduced, the disk remains the same. If the object-glass is now raised (as it should be) so as again to meet the surface for the immersion focus, it will of course also slightly raise the apex of the cone in the glass; but still the increase of the angle in the distance of the cube is too small to be detected.

Mr. Mayall takes the air angle as shown in the glass for uncovered objects, then adjusts the lenses for immersion, and attributes the increase of angle always thus obtained by a nearer approximation of the lenses, to the introduction of water, or the immersion!! This needs no comment.

Professor Stokes would perhaps think it a profitless waste of time to wade through the wearisome length of this controversy. Mr. Mayall imagines that he has secured him as an ally. I need not question the Professor's authority, but I can only say that if he shows mathematically that the principles involved in my "simple demonstration" are not right, I shall have no hesitation in demonstrating practically that he is wrong.

Finally, if Mr. Mayall, or anyone that yet believes that in ordinary immersion object-glasses, the angle in glass is increased by a water connection between the front lens and glass surface, I shall be happy to give a demonstration with any object-glass that he may choose to bring. I am in town every day, with all necessary appliances at hand, and with due notice would have all ready, so that no time should be lost.

I am, Sir, yours obediently,

F. H. WENHAM.

### THE SLIT AS AN AID IN MEASURING APERTURE.

*To the Editor of the 'Monthly Microscopical Journal.'*

SIR,—I do not gather from Professor Keith's communication that in the measurement of aperture he brings forward any argument against the use of the slit for preventing false light from entering the object-glass. This light has hitherto deceived many. Let any objective be adjusted to uncovered, so that all aberrations at this point are corrected: the outer plane of the slit is then set in the focus, in the way that I have described. The slit need not be very narrow, but is opened out to the full extent of the field of view: it is now absolutely correct for uncovered aperture, from which it cannot cut off any rays coming to the focus. It may be argued, that if the object-glass is now closed for "covered" and tried again with the slit in the most distinct approximate focus, that by cutting off the aberrant rays of the pencil, as shown in Professor Keith's diagram, Fig. 2, it should show less aperture, but such in reality is not the case; the aperture has increased in the usual ratio from uncovered to covered. But of course I do not maintain that this is correct. If immersion apertures are to be taken with the front lens and slit immersed, the object-glass must be adjusted for immersion and the focus brought to the plane of slit—and this way I have always used it. The slit does cut off false light seen up to near the impossible angle of  $180^\circ$ , and in no object-glass that I have yet tried by any maker, does the immersed angle exceed  $82^\circ$ , but in all cases has fallen far short of it.

As false positions have been drawn by opponents of ways to use the slit improperly, in order to convey the impression that after having devised the instrument I do not know how to use it rightly, I can see no use in arguing the question. I am always ready to prove my case by giving a demonstration; but in America I cannot do this for some time to come.

I am, Sir, yours obediently,

F. H. WENHAM.

### HASERT'S OBJECTIVES.

*To the Editor of the 'Monthly Microscopical Journal.'*

SIR,—I have good reason for believing that even Mr. Hickie's guarded statements with respect to Hasert's objectives will not be endorsed by those who are better acquainted with their performance; no one will be inclined to accept the vague and uncertain utterance put forth, that they "are capable of performing truly wondrous feats:" indeed, it would appear that no very exalted opinion is entertained of Hasert's lenses by his own countrymen.

Dr. Dippel, in his work 'Das Mikroskop,' p. 168, 1872, tells us "that the beauty and clearness, definition, of images when viewed by direct illumination with Hasert's objectives, cannot be for a moment compared with the performances of either Hartnack or Amici's immersions. They are found wanting in the resolution of lined objects

(diatoms), and in other departments of practical microscopy, since the working distance is extremely small." He further warns his readers against the pretensions put forth in advertisements to the effect that "Hasert has succeeded in making objectives which render the screw-adjustment no longer necessary;" as he (Dr. Dippel) found that this maker's lenses do not work through cover-glasses, which Hartnack's easily do. As to the mechanical work of Hasert's *newest* objective, I may say that no tyro in our English workshops would think of turning out anything so clumsily primitive. A point of far greater importance to microscopists is, that the lens although alleged to be a sixteenth is a much lower power.

I remain yours, &c.,

F.R.M.S.

MR. BRANWELL'S PROPOSED PRIZE FOR THE BEST OBJECTIVE.

*To the Editor of the 'Monthly Microscopical Journal.'*

SIR,—I regret that any words of mine should have been construed by so courteous a writer as Mr. Branwell into an implication against the integrity of the opticians. Such an implication was far from my thoughts. Moreover, I have reason to believe the opticians have seen nothing invidious conveyed in my allusions to them.

The persons most interested in the award of medals—the opticians—have little respect for amateur opinions of lenses. They know the testing of lenses to be such essentially special and difficult work—depending so much on the training of the eye, on manipulative skill, on judgment in the management of the illumination—that they do not readily believe an amateur can possess the qualifications necessary to enable him to give a valuable opinion.

The awarding of medals for objects made for sale necessarily produces an immense amount of vexation among the unsuccessful, and, in many cases, draws a sharp line excluding them ever after from being fairly judged on their merits.

Mr. Branwell sets too high a value on the security of the "unimpeachable ability" of the jury in the selection of the prize lens. The past history of competitive awards, as shown at the exhibitions since '51, teems with strange incidents scarcely known except to opticians. If he wishes to be informed of these matters, there are two sources of information: the fortunate exhibitors, and the unfortunate. From the former he may learn how amateur jurymen have come to the task lacking the main qualifications valuable in the eyes of the expert; how, after a mass of confused hesitation, it has happened that judgment has been pronounced in favour of qualities which the optician knew to be of quite inferior importance,—the *real points* of excellence being seldom discoverable by the amateurs, whilst in nearly every instance they have been indebted to the opticians for the very terms in which to express their judgments! From the *unfortunate* exhibitors he may learn that however eminent may have been the names of jurymen, that was no security for their "unim-



peachable ability"—no guarantee on which reliance could be placed for thoroughly careful and impartial judgments being given. That these opticians have not, as a rule, cared to stir up this subject, is far more owing to apprehensions of the danger of attempting to re-argue a verdict once given, than to any sense of weakness in their basis of complaint. What optician dares publicly call attention to such matters when he knows that every word he utters will be viewed with suspicion, while, on the other hand, a few condemnatory remarks from a jurymen may do him irreparable injury?

The appointment of a jury for the purpose of deciding on the absolutely best histological lens would amount to an attempt to force a general agreement, and would compel opticians either to submit to the verdict or place themselves openly in opposition to the scheme.

Here then are some of the grounds upon which I should anticipate that medal-awarding, annually or triennially, would produce confusion and discord among us,—would neither attain the end sought, nor in any manner increase the scientific *status* of the Royal Microscopical Society.

In the pages of the 'M. M. J.' we find expressions of very diverse opinions as to the utility of high angles of aperture; but this diversity exists principally with reference to lenses of less power than  $\frac{1}{2}$ . The reconciliation of these opinions is probably only to be attained by microscopists being provided with both high and low angled lenses. But if we look to *high-power results*—those embodying the highest magnification and finest definition, which exhibit a marked advance on all former results—we find the most *conspicuous* have been produced with high-angled lenses,—for example: Dr. Woodward's splendid series of photographs of Nobert's lines, diatoms, histological objects, &c. The advocates for low angles have the field open to them—to exhibit any equivalent magnifications that will bear comparison with these photographs; if they cannot do so, they must stand aside and no longer obstruct the onward march of the construction of high powers.

Your obedient servant,

F.R.M.S.

---

### REPLY TO "CRITO."

To the Editor of the 'Monthly Microscopical Journal.'

224, REGENT STREET, LONDON, December 4, 1875.

SIR,—With reference to the *luminous* field obtained with certain immersion lenses, whilst with pneumo-lenses the field is dark, when used on a balsam-mounted object illuminated by Wenham's Reflex Illuminator, it should be noted that "Crito," in his first letter, professed to "perfectly account for the phenomenon" by suggesting a difference in the angular apertures of the lenses used. In reply, I pointed out that the apertures in the sense implied by him do not explain the matter; but that the true explanation is to be found in the fact demonstrated by Dr. Woodward and Professor Keith,—that

*immersion lenses constructed on certain formulæ transmit rays of greater angle than corresponds to the maximum air-angle.*

"Crito" now offers a totally different explanation, ignoring my criticism, apparently unconscious that he must retract his former fallacious explanation before he is entitled to start afresh on the same subject.

My observation, that a certain  $\frac{1}{5}$ th lens, when tried by the test of deep oculars, did not give definition beyond about one thousand diameters, seems to have puzzled "Crito,"—he cannot realize it. He says the answer to such a statement is "so obvious that the discussion is puerile: *the initial power is greater.*"

The discussion would indeed be puerile if so obvious an answer had been effective and had escaped my notice. But "Crito" is again in error: it is not true that the initial power of a  $\frac{1}{5}$ th is necessarily greater than 1000 diameters. The *initial power* of a lens depends on the length of optical body and on the ocular used.

In the list of magnifications belonging to the particular stand and oculars (Hartnack's) I used to determine the limit of definition in Zeiss's lenses, *the initial power of a  $\frac{1}{5}$ th is given as 820 diameters!* In Zeiss's list it is given as 680.

Your obedient servant,

JOHN MAYALL, JUN.

#### AN ANIMAL-LIKE DIATOM.

*To the Editor of the 'Monthly Microscopical Journal.'*

SIR,—The diatom figured in 'Nature,' and reproduced in the 'M. M. J., is a Cocconeis, probably the common *C. scutellum*. Pseudopodal-like appendages are not a new discovery or peculiar to this form. Ehrenberg gave a figure of a *Surirella*, *S. gemma* (I think in his 'Infusionsthierchen'), afterwards reproduced by Pritchard in his third and fourth editions of the 'Infusoria,' pl. xii., fig. 4, surrounded by a fringe of stout setæ. Professor Smith remarks (see Pritchard, third edition) that he has often seen *S. gemma* in this condition, but he never detected any motion in these appendages, and considers them to be a parasitic growth.

I once found *Campylodiscus clypeus* with similar gelatinous prolongations attached to the margins of the frustules; when first observed they were in a very vigorous condition, but after the lapse of a few weeks the frustules gradually died and the fringe disappeared. I do not think the growth was parasitic, but was an abnormally large development of the mucous envelope which all diatoms secrete in a greater or less degree. I once saw *Navicula seriens* in series like a *Fragilaria*, the frustules being held together by a mucous envelope. This secretion is sometimes amorphous, with the diatoms scattered in it as in *Mastogloia*, or it assumes a definite form, as in *Schizonema* and *Encyonema*, in which it forms long hair-like filaments, or it is secreted in greater quantity at one end than the other, forming stipes as in *Cocconema* (I have seen this form growing vigorously without

the vestiges of stipes), Gomphonema, &c. Mr. Wood's discovery!! will therefore not do much in altering the opinions of naturalists as to the vegetable nature of the Diatomaceæ, and it is probable a few years' study of these forms will satisfy him that they are as much vegetable as the Desmids or any other of the simpler forms of algae.

I remain, Sir, yours, &c.,

F. KITTON.

### "MICROSCOPICAL SCIENCE."

*To the Editor of the 'Monthly Microscopical Journal.'*

SIR,—F.R.M.S. says, in his remarks on Mr. Branwell's proposed prize for the best objective, "I remember some years ago a large sum of money was subscribed to the 'Quekett Memorial Medal Fund,' to be given at the discretion of the Council to such member of the Society who, in the opinion of the Council, has best promoted the interest of *Microscopical Science*." Like Mr. Clennam, "I want to know" what is "microscopical science," and I fear until this question is satisfactorily answered the gold medal will not be struck. Although ashamed of my crass ignorance, I do not hesitate to attach my name to this inquiry.

Your obedient servant,

F. KITTON.

### A NEW FORM OF FREEZING MICROTOME.

*To the Editor of the 'Monthly Microscopical Journal.'*

PENDLEBURY, MANCHESTER.

SIR,—In all the freezing microtomes hitherto described, the requisite degree of cold is produced by the use of a freezing mixture of ice and salt, the preparation of which is so troublesome and the action so tedious that the method of freezing is but little used for the examination of tissues, except in the laboratory. A freezing microtome suitable for the post-mortem room, where the immediate examination of diseased tissues and morbid growths is of extreme importance, is still a desideratum. By substituting the ether spray for the freezing mixture as the cold-producing agent, I have arranged an apparatus in which all the advantages of the freezing method are secured with a minimum expenditure of time and trouble.

The apparatus consists of a rectangular brass box, through which near to one side passes a brass cylinder provided with a screw piston, in no way differing from that of a Stirling's section-cutter. In the side opposite the cylinder is an aperture in which the glass tube of an ordinary fluid atomizer is inserted. The top of the box is closed by a brass plate hinged in the middle, so that one half forms a lid, through which ether is introduced when the apparatus is used. An exit tube for the vapour is provided in the side close behind the

cylinder; this tube dips down into a narrow secondary chamber, in which the razor blade is cooled previous to making a section, thus utilizing the waste vapour. A double elastic ball for producing a continuous current of air is attached to the atomizer; or in the laboratory a connection may be made with the nozzle of a gas blow-pipe. To prepare the apparatus for use, a quantity of "Richardson's compound anæsthetic ether" is introduced into the box; the tissue, imbedded or not, is placed in the cylinder, and the razor blade is placed in its chamber; by working the elastic ball for two or three minutes the tissue is frozen sufficient for sections to be cut with the greatest ease.

It may be objected that the line of the hinge on the stage is an obstruction to the free play of the razor blade; in practice I have not found any difficulty from that source. It is necessary that the points of the atomizer should be easy of access, to admit of their being readily cleaned, as they are apt to become choked by small foreign bodies, dirt, &c.; for this reason the opening to the interior of the box must be of sufficient size. The cost of the ether is but a small item; it is sold by Robbins, of Oxford Street, at seven shillings a pint; three drachms are sufficient in cold weather to freeze a portion of tissue five-eighths of an inch in diameter, and by an occasional squeeze of the india-rubber ball to keep it frozen for several minutes.

The apparatus is arranged to stand upon four firm legs, thus having the advantage of portability, and is covered by a coat of felt and leather to prevent conduction. It is made by Messrs. Wood and Son, King Street, Manchester.

Yours, &c.,

RICHARD HUGHES.

## PROCEEDINGS OF SOCIETIES.

### ROYAL MICROSCOPICAL SOCIETY.

KING'S COLLEGE, *December 1, 1875.*

Chairman, H. C. Sorby, Esq., F.R.S., President.

The minutes of the preceding meeting were read and confirmed.

A list of donations to the Society was read by the Secretary, and the thanks of the Society were voted to the donors.

Mr. Beck said he had a slide to present to the Society which he thought would be of interest, being some of the ova of the Amphiuma, which he had described at a former meeting,\* and which he then mentioned he hoped he should on a future occasion be able to get mounted. The specimen had been injected by one of their Fellows, Mr. Needham, and would be placed under a microscope in the room for exhibition at the close of the meeting. It was a rare circumstance to get the animal at all in this country, and still more rare to get one

\* Nov., 1875; see 'M: M. J.', p. 265.

containing ova, so that it might be regarded as an object worth a place in the cabinet.

The thanks of the Society were voted to Mr. Beck for the present.

The Secretary said that they were very much indebted to Mr. Baker and Mr. How, for the loan of a number of microscope lamps for use at their Scientific Evening on the preceding Wednesday; the thanks of the Society were accordingly voted to those gentlemen.

Dr. Lawson said he had to exhibit an invention of M. Hayem, made by M. Nchet, of Paris, and termed a Hematimètre, for the purpose of estimating the amount of red corpuscles in the blood. It was not strictly speaking a novel instrument, but it was new in form. Various apparatus had from time to time been devised for the purpose, but none of them were very convenient, inasmuch as they all required several hours' interval for the investigation, whereas the one before the meeting was much more simple and more easily used. It consisted in the first place of a slide having cemented to it a piece of glass with a hole cut in it, and then reduced to a certain level so as to have a depth of exactly one-fifth millimeter. In the eye-piece of the instrument there was a sort of micrometer, also arranged so as to give a view of only the space of one-fifth millimeter, the object of this being to procure for examination exactly the volume equal to the one-fifth of a millimeter cubed. If, however, they were to take exactly that amount of blood for examination, they would find such an agglomeration of corpuscles that it would be impossible to estimate them; but for the purpose of being able to enumerate them, M. Hayem took a graduated tube, and having measured 2 cubic millimeters of blood and placed this in a small vessel, he measured into another vessel half a cubic centimeter of serum, and then having put the blood into it he stirred them up so as to make the mixture complete. He then placed sufficient fluid from this mixture in the cavity of the slide to exactly fill it, and put it under the microscope. Then by focussing the instrument upon it, it was possible to readily count the number of corpuscles in the one-fifth of a millimeter cubed. He (Dr. Lawson) had endeavoured to count them in that way, and found the number in the ruled space to be 142; and by multiplying this number by 125 and then by 251 (which corresponded to the quantity of serum employed + 1) he obtained  $142 \times 125 \times 251 = 4,455,250$ , as the number of corpuscles in an ordinary cubic millimeter of blood.

Mr. Charles Brooke said that if the amount were one-fifth cubic millimeter, then it would not do to multiply by 125, the 142 should be in that case multiplied by 5 instead; but if a cube of one-fifth millimeter were intended, the result as stated would be correct.

Dr. Lawson said that he had intended it to be understood as a cube of one-fifth millimeter.

The Secretary said they had a microscope brought for exhibition by Mr. Crouch, the peculiarity of which was that it was furnished with an arrangement for exactly centering the stage for the particular objective which was being used, and he called upon Mr. Crouch to further explain the improvement to the meeting.

Mr. Crouch thought it scarcely necessary to say anything further,

but would just observe that all who were in the habit of using a concentric stage, especially with high powers, were aware how difficult it was always to keep the object in view, in consequence of some very slight difference between the centering of the stage and the objective; even a jar would sometimes alter an objective in this respect, so that one which was perfectly true when sent out by the maker might be thrown out by being thrown down roughly in carriage. The addition to the microscope exhibited was designed to enable any person to centre the stage accurately to the object he was using.

Mr. Charles Brooke thought this was a very good idea for effecting a very useful purpose. He had frequently met with the difficulty which it was designed to obviate, and believed it most frequently arose from the screw not being exactly central, and in which minute differences—far more minute than any practical mechanism could overcome—would be enough to cause a very appreciable error in the case of a high power. He believed that it was a circumstance which no ingenuity could overcome, and that no centering, however carefully arranged, would under all circumstances be found perfect.

The thanks of the meeting were voted to Mr. Crouch for bringing the improvement before their notice.

Mr. Alfred W. Bennett read a short paper relative to certain organs which he had observed on the leaves of *Drosera* and other carnivorous plants, and to which he had lately drawn attention in the 'Popular Science Review.' The subject was illustrated by numerous preparations exhibited under the microscope. (The paper will be found printed at p. 1.)

The President, in proposing a vote of thanks to Professor Bennett for his communication, inquired if there was a definite relationship observed between the characters of the tropical plants which had these glands, and those which were allied to *Drosera*.

Mr. Slack said these objects were evidently quite distinct from those which belonged to *Coleus*, which seemed to be only modifications of glandular hairs. In *Coleus* the stems on which these glands were erected were very short, but in others, such as *Lavender*, they were long stems with knobs on the top. On *Coleus* there was a distinct cross, like a hot-cross-bun mark, indicating a tendency to divide. He happened to have a slide of a piece of *Digitalis* leaf from Calcutta, in which there was a complete division, forming a cross of four cells. The internal glandular objects described by Professor Bennett evidently had quite another function.

Mr. Bennett said he had frequently observed these structures imbedded in the leaf immediately beneath the tentacles. They were not hair structures in any sense of the term.

The President called the attention of the meeting to the fact that a post-card had been received from Germany, addressed to Mr. Hardwicke, saying that Herr Möller's proposed work on the Diatomaceæ would not be published.

Mr. Beck said he had also received a communication of the same kind, and inferred that the number of subscribers for the work was deemed insufficient, and that therefore it would not be brought out.

Professor Rupert Jones then read a highly interesting paper "On the Foraminifera, with special reference to their Variability of Form." The subject was illustrated by a large number of diagrams and enlarged models in plaster, &c., as well as by an extensive collection of mounted specimens. (The paper will appear in the next number, not having been received by the Editor.)

The President expressed the pleasure with which he had listened to Professor Jones, and thought there were in the paper a great many points which claimed their attention, the principal being of course the remarkable variability of these little organisms. He hoped this would be experimentally tested by keeping the creatures in confinement and breeding them. It really seemed almost impossible to draw a line in any particular part of the series between the species, and one felt it very difficult under such circumstances to say what a species was. Occurring as they did in such immense numbers, they supplied the opportunity of studying the many differences of form and variations from a type that were likely to occur. He presumed that no experiments had been tried on the subject, but it appeared to him very interesting to keep these little creatures for the purpose of such a study if it could be done. The question of opacity of certain forms must be due in some degree to the ultimate molecular structure of the shells, some allowing the light to pass through more freely than others.

Mr. C. Stewart said that amongst so large a class of bodies there must be a great number of intermediate forms, and not only would the forms themselves vary, but the intermediate links would constantly vary also. With regard to the structure and transparency of these shells, it would be found that they polarized light in a very marked and definite manner. All the hyaline ones showed the "black cross" in the clearest way, but all the porcellanous varieties showed only a general irregular mottling, and they did not lose that appearance by alteration of the plane of polarization, but in any position still appeared generally mottled.

The President thought the remarks of Mr. Stewart very important, the cause of the difference observed between the two kinds in polarized light was no doubt due to their structure. If the carbonate of lime were arranged in crystals all perpendicular to the surface of curvature, that would account for the "black cross." The other appearance was analogous to what would occur if the particles were arranged in every possible direction, the one being a regular and the other a promiscuous arrangement.

A cordial vote of thanks to Professor Jones was unanimously carried.

*The Scientific Evening, November 24, 1875.*

The attendance on this occasion was very good, and from the subjoined list it will be seen that many objects of interest were exhibited.

The President's apparatus for measuring the exact position of absorption bands, and which is described and figured in the December



number of 'M. M. J.' attracted great attention; and was found very easy to work.

Mr. J. Badcock: The water-net, *Hydrodictyon utriculatum*.

Messrs. R. and J. Beck: The ova of *Amphiuma* injected, and crystals of pure gold. [libtool.com.cn](http://libtool.com.cn)

Mr. W. H. Beeby: Leaf of *Sherardia arvensis*.

Mr. Thomas Bolton: *Melicerta tyro* (Hudson).

Mr. Charles Baker: A series of objectives, from 1 inch to  $\frac{1}{2}$  inch, by Zeiss; and a new glycerine adjustment lens by Gundlach.\*

Mr. Henry Crouch: A new first-class microscope, with stage and sub-stage of new construction.†

Mr. Thomas Curties showed *Aulacodisci*, var. sp., obtained on the late Congo expedition by Mr. Martin, H.M.S. 'Spitiful.'

Mr. Fitch: Anatomy of a spider's head.

Dr. W. J. Gray: Teeth of leech *in situ*.

Messrs. How: Section of chalk; fossil wood from the London clay, showing Tylosis; silicified wood from a chalk flint, &c.

Mr. Thomas Howse: Antheridia and Antherozoids of a moss (*Sphagnum*), and section of the stem and leaves of a moss (*Polypodium*).

Mr. C. L. Jackson: Glands on a leaf; and the skin of the spotted gunnel.

Mr. W. Moginie: Selected Diatomaceæ from the Red Sea.

Mr. S. J. McIntire: Some curious lepidopterous scales from a *Lycena*.

Mr. J. Needham: A series of preparations illustrating the morbid anatomy of the human liver.

Mr. Walter W. Reeves: Young of the pea-urchin, *Echinocyamus pusillus*.

Mr. Thomas Shephard sent from Chester some specimens of *Stephanosceros* and *Floscularia*.

Mr. H. J. Slack: Inner envelope of coffee berry, with polarized light.

Mr. Charles Stewart: Silicious sponge (*Farrea*).

Mr. H. C. Sorby: His new contrivance for measuring the position of the absorption bands in spectra.

Dr. Millar: The tongues of some insects.

Mr. J. S. Townsend: Fructification of *Lygodium*.

Mr. J. R. Williams: Poison-fang of cobra de capello.

Mr. Thomas C. White: Crystals of gold; and *Demodex folliculorum* alive.

Mr. F. H. Ward: Section of umbilical cord, with connective-tissue corpuscles; and proboscis of *Chærocampa elpenor*.

Mr. J. W. Stephenson: Cocconeis from Manilla, showing the pseudopodia-like bodies (as figured in 'M. M. J.'), stained with hæmatoxylin, and mounted in gum mastic dissolved in absolute alcohol; *Aulacodiscus* from Bolivian guano, with Zeiss's D objective, under Stephenson's binocular.

\* Not immersion; glycerine, the correcting element, being within the combination.

† See 'Proceedings,' Dec. 1.

## Donations to the Library and Cabinet from November 3, 1875 :

	From
Nature. Weekly .. .. .	<i>The Editor.</i>
Athenæum. Weekly .. .. .	<i>Ditto.</i>
Society of Arts Journal .. .. .	<i>Society.</i>
Journal of the Royal United Service Institution, four parts, containing Delineations of some Minute Sea-surface Animals. By Mrs. Toynbee .. .. .	<i>Institution.</i>
The Natural History of <i>Euglena viridis</i> . By E. Parfitt .. .. .	<i>Author.</i>
Quarterly Journal of the Geological Society. No. 124 .. .. .	<i>Society.</i>
Observations on the Sizes and Shapes of the Red Corpuscles of the Blood of Vertebrates. By George Gulliver, F.R.S. .. .. .	<i>Author.</i>
Bulletin de la Société Botanique de France .. .. .	<i>Society.</i>
Transactions of the Watford Natural History Society. Vol. I., part 2 .. .. .	<i>Ditto.</i>
Proceedings of the Literary and Philosophical Society of Liverpool, 1875 .. .. .	<i>Ditto.</i>
Two Slides .. .. .	<i>C. L. Jackson, Esq.</i>
One Slide (the ova of <i>Amphiuma</i> injected) .. .. .	<i>Messrs. Beck.</i>

The following gentlemen were elected Fellows of the Society :—  
 Lieut. Richard Benyon Croft, R.N.; John J. Hamilton, Esq.;  
 C. L. Jackson, Esq.

WALTER W. RENVES,  
*Assist.-Secretary.*

## MEDICAL MICROSCOPICAL SOCIETY.

Friday, November 19, 1875.—Dr. Pritchard, Vice-President, in the chair.

*Micro-photography.*—Mr. George Giles read a paper on and exhibited an instrument for quickly connecting an ordinary microscope with an ordinary camera, and obviating the use of the heliostat (see p. 26).

At the conclusion of this paper the Chairman suggested the use of a frosted silver mirror to supply a white light.

Dr. Matthews proposed using a paraffin lamp with double flame; and stated that, in order to save daylight, plates need not be developed at once, but could be put aside safely for some hours if wetted with treacle and water. The yellow colour of the specimens, if it were requisite, might be corrected with hæmatoxylin.

Mr. Giles, in reply, preferred sunlight direct if it could be obtained, and did not find the colour of the slides any drawback.

*Differential warm stage.*—Mr. Golding-Bird explained and exhibited in action a simple form of hot stage, heated by a spirit lamp, capable of being kept in action for any length of time, its temperature being regulated according to the condition of pieces of solid paraffin placed on it, and on a copper tongue connected with it. He had found it extremely useful for purposes of demonstration, and its simplicity allowed of its being used in the wards of an hospital when examining blood in a morbid state.\*

A discussion followed, and the meeting then resolved itself into a conversazione.

\* This stage has been already described in 'Quarterly Microscopical Journal' for October, 1875, and is made by Millikin, of St. Thomas Street, Southwark, S.E.

## QUEKETT MICROSCOPICAL CLUB.

Ordinary Meeting, October 22, 1875.—Dr. Matthews, F.R.M.S., President, in the chair.

A communication from Mr. E. Gardner was read, suggesting the use of gum water (to which a little syrup of loaf sugar was added to prevent cracking) in mounting *Ostracoda* and similar organisms. Cells could be filled with this substance, and afterwards surrounded with gum dammar, and so permanently preserved.

The President stated that it was intended to obtain an album for containing the photographs of members; which he requested might be sent for that purpose.

Mr. Bolton, of Stourbridge, exhibited the new rotifer, *Melicerta tyro*, and communicated some particulars respecting it.

Mr. B. T. Lowne gave an address "On some Recent Views of the Classification of the Lower Animals," with particular reference to the use of the terms *Protozoa* and *Metazoa*.

Ordinary Meeting, November 25, 1875.—Dr. Matthews, F.R.M.S., President, in the chair.

The President announced that three albums had been presented to the club—a large one by Mr. F. W. Gay, and two smaller ones by Mr. J. W. Goodinge, and he requested that members would forward their photographs for insertion in them.

Mr. R. T. Lewis described some specimens of the *Edelweiss*, a rare and beautiful Alpine flower, which he had mounted for the cabinet of the club.

Mr. B. T. Lowne gave an interesting account of the various researches which had been made by Mr. Darwin and others into the nature of Insectivorous plants.

Mr. T. Charters White read a paper, in which he treated of the various structures likely to be seen in an ordinary section of a tooth by the general observer. After alluding to a short paper he read before the club four years ago on the Dental Pulp, in which he described the dentine-forming organs or Odontoblasts, and a remembrance of which would help them in understanding the histological construction of the principal portion, he proceeded to describe the process of development in the enamel, the dentine, and cementum.

The teeth may be regarded as dermal appendages, proofs of which fact may be seen in the teeth studding the rostrum of the saw-fish (*Pristis antiquorum*), or in the spear of the narwhal, at other times occupying the interior of the alimentary canal, as in the crustacea, and being periodically shed with the shells of these creatures, while in the human subject they occupy an intermediate position in this range, and are placed only a few inches from the external surface of the body, but partaking largely of the character of the dermal structures. The author did not promise the members that he could furnish them with any new facts as the result of original work, but would fairly represent the views of such workers in this department of histology as Sharpey, Tomes, Kölliker, and Stricker, and referred those interested in his subject to the works written by these gentlemen. He then pro-

ceeded to describe in detail the formation of the enamel, the dentine, and the cementum in a well-developed tooth, and pointed out, secondly, the departures from this normal condition met with in these several structures, such as the extension of the dentinal tubuli into the enamel, the formation of globular dentine and osteo-dentine, the hypertrophied condition of the cementum known as dental exostosis; the principal object of the paper being to afford information to the young and general observer relative to the various appearances presented to his notice in examining sections of teeth.

#### MEMPHIS (U.S.A.) MICROSCOPICAL SOCIETY.

At the regular meeting, August 19, the annual election of officers was held, resulting in the re-election of the old board, with S. P. Cutler, M.D., as President, and H. F. Dod as Secretary.

The Secretary's annual report sets forth—

The Society was organized August 28, 1874, with a list of twelve members; and during the year twenty-three others have been added, giving an active membership of thirty-five. A thoroughly good microscope has been purchased, fitted with all needed accessories; and a collection of several hundred valuable and interesting objects has been accumulated. The regular meetings have always been well attended, and their interest well maintained. The following list embraces the most important "papers" which have been contributed during the year: "Light and Optics," "Some Forms of Infusorial Life," "Notes on the House-fly," "Tolles' New  $\frac{1}{10}$ th *versus* his Old  $\frac{1}{50}$ th," "Dammar as a Mounting Medium," "Blue Glass Illumination for Difficult Tests," "A Method of Mounting Insects Entire," "Notes on Micro-crystallography," "Modern Wide-angled *versus* Old Low-angled Objectives," "On the Examination of a Certain Pathological Specimen," "On the Organisms in 'Happy Hollow' Water," "Measurements of the Striæ on the Diatoms of the Probe-Platte," "On the Preparation of Silica Films," "Further Remarks on Wide *versus* Narrow Angles," "Measurements of Probe-Platte," "The Cyclops," "Plant Crystals," "Preparation of Coal Sections," "The Water Flea," "Silica Films and their Bearing on the Structure of Diatoms," most of which have been published in the journals of this country or England. Many minor articles have also been presented. The Society's indebtedness to its corresponding members for their valuable aid was most heartily acknowledged.

On ballot, C. B. Johnson, M.D., of Providence, and Ed. Wheeler, Esq., of London, were elected corresponding members. Valuable contributions of prepared objects were received from Dr. C. B. Johnson and Mr. Henry Mills, for all which a vote of thanks was passed.

The President's annual address was then read, after which the Society adjourned to first Thursday in September.

[www.libtool.com.cn](http://www.libtool.com.cn)

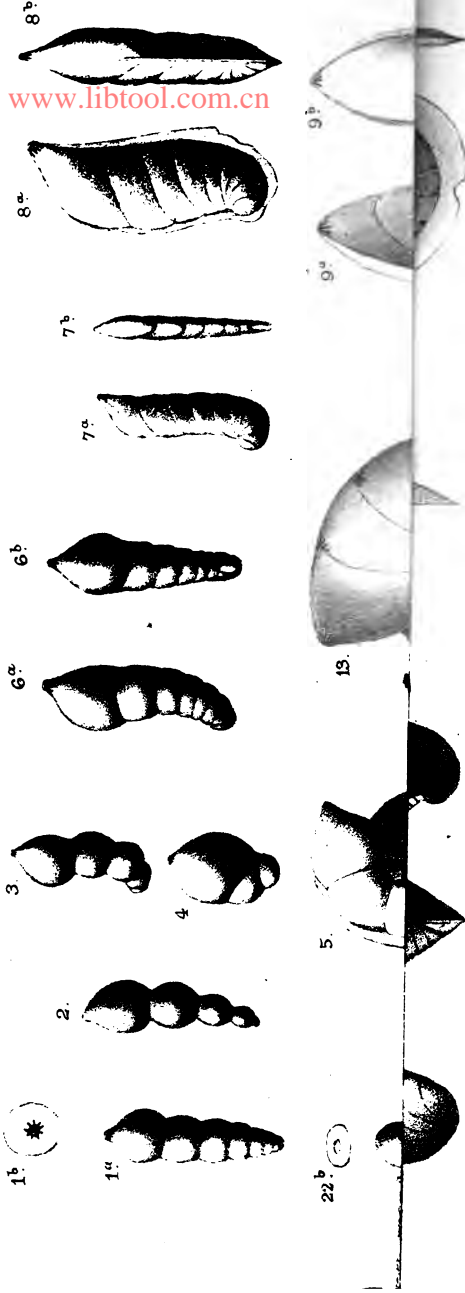

THE  
MONTHLY MICROSCOPICAL JOURNAL.

www.Humanity.org.uk  
FEBRUARY 1, 1876.

I.—*Remarks on the Foraminifera, with especial reference to their Variability of Form, illustrated by the Cristellarians.*

By PROFESSOR T. RUPERT JONES, F.R.S., F.G.S.

(Read before the ROYAL MICROSCOPICAL SOCIETY, December 1, 1875.)

PLATES CXXVIII., CXXIX.

CONTENTS.

Introduction.

Systematic grouping of the Foraminifera.

Shells of the Imperforata.

Shells of the Arenacea.

Shells of the Perforate or Hyaline Foraminifera.

The Hyaline Foraminifera.

Lagenida.

Lagena.

Nodosaria, Cristellaria, &c.

Cristellaridea.

Gradations of the Cristellaridea.

Conclusion.

Remarks on the Cristellarians figured in Plates CXXVIII. and CXXIX. in illustration of their Variability.

*Introduction.*—This paper is not intended to be exhaustive; and, with little that is novel, it aims at giving a general view of the structure and affinities of the Foraminifera and of their extreme variability.

As is well known to Microscopists, foraminiferal shells can be obtained from numerous marine sands, silts, muds, and clays, recent

DESCRIPTION OF PLATES CXXVIII. AND CXXIX.

PLATE CXXVIII.

- FIG. 1.—Max von Hantken's 'Die Fauna der Clavulina-Szabói-Schichten,' 1875, p. 23, pl. 2, fig. 5 (part). *Nodosaria Beyrichi*, Neugeb.\* (= *Nod. radiculata*, Lin.). a, side; b, end, with radiate terminal orifice.
- " 2.—v. Hantken, p. 29, pl. 3, f. 14 (part). *Dentalina soluta*, Reuss.
- " 3.—v. Hantken, p. 45, pl. 4, f. 12 (part). *Marginulina pediformis*, Bornemann.
- " 4.—v. Hantken, p. 46, pl. 5, f. 9 (part). *Marginulina subbullata*, Hantk.
- " 5.—v. Hantken, p. 58, pl. 7, f. 1 (part). *Robulina Budensis*, Hantk.
- " 6.—v. Hantken, p. 87, pl. 4, f. 11. *Marginulina splendens*, Hantk. a, side; b, inner edge.

[FIG. 7.

\* "*Nodosaria Neugeboreni*, Reuss," in the explanation of the Plate.



and fossil, by careful manipulation, and very easily from the sponges of commerce, which often become charged with them when trodden about, in process of drying, on richly foraminiferal beaches. Sometimes half the material of a beach-sand consists of Foraminifera. In some tropical islands, shoals and beaches are formed wholly of the shells of *Orbitolites*, *Tinoporus*, *Operculina*, &c. Fresh seaweeds placed in salt-water aquaria, fresh oyster-ooze and other marine muds washed in sea-water, fine surface-nets and under-water trailing bags, are among the means of obtaining living specimens. In the fossil state Foraminifera constitute great stratified masses, such as the Fusulina limestone of Russia and elsewhere, the Saccaminal limestone of Northumberland, much of the White Chalk, the Nummulitic limestone of Europe, Asia, and North Africa, the Miliolitic limestone of Paris, Alveolina limestone of

- FIG. 7.—v. Hantken, p. 87, pl. 14, f. 4. *Cristellaria elegans*, *Hantk.* a, side; b, inner edge.  
 „ 8.—v. Hantken, p. 49, pl. 5, f. 11. *Cristellaria Schwageri*, *Hantk.* a, side; b, inner edge.  
 „ 9.—v. Hantken, p. 53, pl. 5, f. 6. *Cristellaria arcuata*, *D'Orb.* a, side; b, inner edge.  
 „ 10.—v. Hantken, p. 49, pl. 5, f. 3. *Cristellaria cymboidea*, *D'Orb.* (= *Planularia crepidula*, F. and M.). a, side; b, inner edge.  
 „ 11.—v. Hantken, p. 51, pl. 6, f. 4 b. *Cristellaria nummulitica*, *Gümb.* a, side; b, inner edge.  
 „ 12.—v. Hantken, p. 56, pl. 6, f. 7. *Robulina Kubinyii*, *Hantk.* a, side; b, inner edge.  
 „ 13.—A. D'Orbigny's 'Foraminifères fossiles du Bassin tertiaire de Vienne,' 1846, p. 102, pl. 4, f. 27. *Robulina simplex*, *D'Orb.* (= *Cristellaria rotulata*, Lamarck).  
 „ 14.—v. Hantken, p. 57, pl. 6, f. 11. *Robulina limbosa*, *Reuss* (= *Cristellaria cultrata*, De Montfort). a, side; b, inner edge.  
 „ 15.—D'Orbigny, 'For. foss. Vien.,' p. 91, pl. 4, f. 4. *Cristellaria cassis*, F. and M.  
 „ 16.—D'Orbigny, 'For. foss. Vien.,' p. 99, pl. 4, f. 18. *Robulina calcar*, *Linne.*  
 „ 17.—v. Hantken, p. 58, pl. 14, f. 9. *Robulina Baconica*, *Hantk.*  
 „ 18.—v. Hantken, p. 53, pl. 5, f. 7. *Cristellaria Kochi*, *Reuss.* a, side; b, inner edge.  
 „ 19.—v. Hantken, p. 54, pl. 13, f. 20. *Cristellaria galeata*, *Reuss.* a, side; b, inner edge.  
 „ 20.—v. Hantken, p. 53, pl. 5, f. 5 a. *Cristellaria arcuata*, *D'Orb.* (= *Saracenaria Italica*, DeFrance). a, side; b, inner edge.  
 „ 21.—v. Hantken, p. 53, pl. 5, f. 5 b. *Cristellaria arcuata*, *D'Orb.* (= *Saracenaria Italica*, DeFr.). a, side; b, inner edge.  
 „ 22.—a, b. O. Terquem's 'Troisième Mémoire sur les Foraminifères du Système colithique,' 1870, pl. 23, f. 7. *Frondicularia dentaliniformis*, *Terq.* (= *Linguline* form of *Frondicularia papa*, *D'Orb.*).  
 „ 23.—Terquem, pl. 22, f. 22. *Frondicularia irregularis*, *Terq.* (= *Lingulina carinata*, *D'Orb.*, *Modèle*, No. 26).  
 „ 24.—Terquem, pl. 22, f. 10. *Frondicularia spissa*, *Terq.*  
 „ 25.—Terquem, pl. 24, f. 15. *Flabellina ponderosa*, *Terq.*  
 „ 26.—Terquem, pl. 23, f. 26. *Flabellina triquetra*, *Terq.*  
 „ 27.—H. B. Brady's 'Synopsis of the Foraminifera of the Middle and Upper Lias of Somersetshire,' 1867, p. 110, pl. 2, f. 25. *Planularia pauperata*, *Jones and Parker.*

[www.libtool.com.cn](http://www.libtool.com.cn)

[www.libtool.com.cn](http://www.libtool.com.cn)

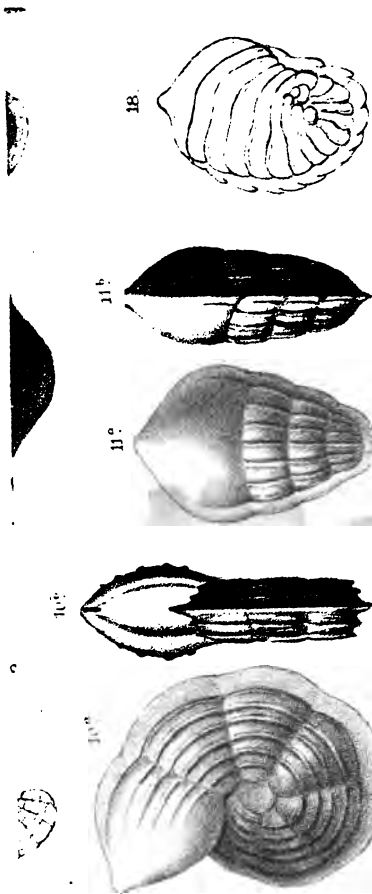

Scinde, Loftusia rock of Persia, Orbitoidal limestones of the Alps, India, Alabama, Jamaica, and Java, and Amphistegina limestone of Australia; besides vastly adding to the bulk of other limestones and many thick clays, and further, by means of their glauconitic casts, to that of numerous sandy and other strata. Some of the oldest rocks even are largely composed of them, in the forms of *Eozoon*,\* *Stromatopora*,† *Receptaculites*,‡ and their allies.

Some kinds of *Orbulina*, *Globigerina*, and *Pulvinulina* have been taken by towing nets at and near the surface of the ocean by Major Owen and others. These constitute also the mass of the abyssal forms. They may have more sarcode in proportion to shell

PLATE CXXIX.

- FIG. 1 a.—Von Hantken, p. 24, pl. 3, f. 1 (part). *Nodosaria spinicosta*, *D'Orb.*  
 " 1 b.—v. Hantken, p. 37, pl. 4, f. 2. *Dentalina Hoernesii*, *Hantk.*  
 " 2.—v. Hantken, p. 48, pl. 5, f. 2 (part). *Marginulina Behmi*, *Reuss.*  
 " 3.—v. Hantken, p. 48, pl. 14, f. 6. *Marginulina Behmi*, *Reuss.*  
 " 4.—v. Hantken, p. 53, pl. 6, f. 3 (part). *Cristellaria fragaria*, *Gümb.*  
 " 5.—v. Hantken, p. 51, pl. 5, f. 10. *Cristellaria arcuata*, *Phil.* a, side;  
 b, inner edge.  
 " 6.—v. Hantken, p. 57, pl. 6, f. 10. *Robulina guttucostata*, *Gümb.* (= *Cristellaria papillosa*, F. and M.). a, side; b, inner edge.  
 " 7.—v. Hantken, p. 57, pl. 14, f. 15. *Robulina granulata*, *Hantk.*  
 " 8.—v. Hantken, p. 28, pl. 2, f. 10. *Nodosaria Budensis*, *Hantk.* (= *Nodosaria raphanus*, Lin.). a, side; b, end.  
 " 9.—'Annals Nat. Hist.,' ser. 4, vol. viii. "Nomenclature of the Foraminifera," by Parker, Jones, and Brady; "Species founded by D'Orbigny on figures in Soldani's 'Testaceographia,' &c.," 1871, p. 163, pl. 10, f. 72. *Marginulina raphanus*, *D'Orb.*  
 " 10.—D'Orbigny's 'Foram. foss. Vienne,' p. 95, pl. 4, f. 8, 9. *Robulina ariminensis*, *D'Orb.* (= *Cristellaria costata*, F. and M., var.). a, side; b, inner edge.  
 " 11.—D'Orbigny's 'For. foss. Vien.,' p. 62, pl. 3, f. 1-3. *Lingulina costata*, *D'Orb.* a, side; b, edge; c, end, with terminal, flexuous, slit-like orifice.  
 " 12.—Brady's 'Foram. Lias,' p. 112, pl. 3, f. 43. *Cristellaria costata*, *D'Orb.* (non F. and M.), keelless subvariety.  
 " 13.—Brady's 'Foram. Lias,' p. 110, pl. 2, f. 30. *Planularia Bronni*, *Römer.*  
 " 14.—Brady's 'Foram. Lias,' p. 111, pl. 2, f. 33. *Planularia reticulata*, *Cornuel.* (= *Vaginulina*).  
 " 15.—D'Orbigny's 'For. foss. Vien.,' p. 90, pl. 3, f. 43. *Cristellaria semiluna*, *D'Orb.* (= *Planularia auris*, DeFr.).  
 " 16.—'Ann. N. Hist.,' 1871, p. 166, pl. 10, f. 75. *Planularia rostrata*, *D'Orb.*  
 " 17.—v. Hantken, p. 43, pl. 13, f. 13. *Flabellina striata*, *Hantk.* a, side; b, edge.  
 " 18.—'Ann. N. Hist.,' 1871, p. 243, pl. 11, f. 101 (part). *Cristellaria navi-  
 cularis*, *De Montf.* (= *Flabellina Cristellaria cassis*, F. and M.).  
 " 19.—D'Orbigny's 'For. foss. Vienne,' p. 104, pl. 5, f. 5. *Robulina imperatoria*, *D'Orb.* (= *Cristellaria vortex*, F. and M., keeled).

\* Dawson's 'The Dawn of Life,' 8vo, 1875. Hodder and Co., London.

† G. Lindström, 'Kongl. Svenska Vetenskaps Akademiens Handlingar,' vol. ix., No. 6, 1870.

‡ Gümbel, 'Transact. Bavarian Acad.' Munich, 1875.

than the others. Like as the few butterflies rising up to the mountain top, have left the many floating in air among the flowers in the valley, so these float upwards in the higher regions of the water, whilst others remain below,—making their tests of deep-sea sand or of spicula, or of Foraminifera themselves,—or attached to rock, shell, or seaweed,—or lying free on the bottom, with other organisms, to be preyed on by *Dentalium* (S. P. Woodward) or *Ophiura* (at 1260 fathoms, Wallich),—to be used up in the shells of some larger congeners,—to be accumulated in strata, —or to be converted into such glauconite as coats the floor of the Mexican Gulf with black-green sand.

The differences of depth at which these Microzoa live, and the concomitant conditions of agitation or repose, of clear or muddy water, much or little nourishment, of relative warmth and light, are easily recognizable. Thus *Polystomella* has a thicker shell in shallow than in deep water; but *Globigerina* is thicker in deep than in shallow; and where it most abounds in abyssal waters, the associated Foraminifera are often few in kind, few as individuals, and very small. Possibly the greater amount of light and warmth that the shallow-water *Polystomellæ* and the floating *Globigerinæ* enjoy, favours their growth beyond that of the more deeply seated and the non-floating forms; but others living even in deep water have thick shells, either meeting with favourable conditions of growth, or having grown thick before they sank to the bottom.

The susceptibility of variation, by relative increase of size, or by modification of shape and mode of growth, or by the thickening and complexity of the shell, belongs to all the systematized groups of Foraminifera.

*Systematic Grouping of Foraminifera.*—There are said to be 4000 recognizably different forms of these little Rhizopodal shells, such as a “superficial observer can separate by words and a name” (Hooker), and these have been sorted according to their apparent alliances into the several divisions of the appended Table (pages 89–92), copied by permission, with slight modifications, from Hefrey and Griffith’s ‘Micrographical Dictionary,’ new edition, 8vo, Van Voorst, London, 1875. These groupings are based, primarily, on the texture of the shell (whether “porcellanous,” “hyaline,” or “sandy”), and secondarily on the arrangement of the segments of sarcode, and the form of the shell-chambers. Neither the fixed (parasitic) habit of shell, nor the single-chambered condition, has weight in this classification, as neither is confined to any one group of the Foraminifera.

Arranged on this plan many dissimilar forms are found to be mutual allies, and even more closely akin; whilst, with some, an external resemblance, chiefly from mode of growth, is mimetic only,—or, rather, a real bond of relationship, arising from the

general kinship pervading the whole Foraminiferal family. Nor does relationship end here; for there are among these Rhizopods structures and habits analogous to, if not identical with, those of other *Protozoa*. Thus the spicular contents of *Carpenteria*, *Polytrema*, and *Stromatocerium* (if not accidental), and the internal structure of some old fossil *Patellinæ* (*Orbitolinæ*) and *Dactyloporidæ*, point towards Sponges; whilst the radial shells of *Calcarina* and *Tinoporus*, and the basket-like or pierced shells of others not so well known,\* remind us of *Polycystina*, though the material be different. Nor should we forget that the *Porcellana*, protruding their sarcode from one part only of the body, are, in so much, more closely allied with their shell-less representatives, than with the *Hyalina* and those Rhizopods which have sarcode processes from the general surface. At the same time we know that it is difficult to define the relative value of pseudopodial characters, which do not coincide with the absence or the development of those more important organs, the "Nucleus" and "Contracting Vesicle," on which Dr. Wallich has based a natural system of classification.† No evidence of either organ having been found in *Foraminifera* and *Polycystina*, they stand (as *Herpnomata*) low in the scale of Rhizopods. A definite nucleus is present in the *Protodermata*, comprising the *Plagiacanthidæ*, *Acanthometrina*, *Thalassicollina*, and *Dactyochidæ*, leading towards *Spongidæ*. Both nucleus and contracting vesicle characterize the *Proteina*, as defined by Wallich, comprising the *Actinophryna* (*Actinophrys*, *Gromia*, *Lagynis*, &c.), and *Amœbina* (*Amœba*, *Diffugia*, *Arcella*, &c.), and leading to *Infusoria*.

A new link between the Foraminifera and the *Polycystina* appears to be indicated in the following extract from one of Dr. Wyville Thomson's Reports on the 'Challenger' Expedition.‡ Off Japan, going eastward [long. 167° E., lat. 35° N.], and before turning south towards Honolulu, "on the 26th of June, we sounded in 2800 fathoms. Several forms were met with [in the towing nets below the surface] which apparently do not occur on the surface, particularly a number of species of a group which is, so far as we know, entirely undescribed. It seems to be intermediate between the Radiolarians and the Foraminifera, resembling the former in the condition and appearance of the sarcode and in the siliceous composition of the test, and the latter in external form." The broken tests were extremely abundant in the red clay of the bottom. §

\* Such as a fenestrated, lageniform, porcellanous Foraminifer, discovered by M. Vanden Broeck, of Brussels, and the pierced Rotalines noticed by Ehrenberg and Joseph Wright. See 'Proceed. Belfast Nat. Field Club,' ser. 2, vol. i., p. 87.

† 'Annals Nat. Hist.,' June 1863, p. 439; 'Monthly Microscopical Journal,' 1865, &c.

‡ 'Nature,' November 25, 1875, vol. xiii., p. 70.

§ See also 'Proceed. Roy. Soc.,' vol. xxiv., p. 35.

If the perforated *Rotalinæ* figured by Ehrenberg and Joseph Wright should prove to be *siliceous* (as indeed the Antrim specimen is, though possibly from pseudomorphic change), we have already noticed analogous intermediate examples.\* Ehrenberg's original *Spirillina vivipara* is described as being *siliceous*; and is a perfect analogue of our common *Spirillinæ*. Possibly some of the common small Microzoa, passing for Foraminifera, under the microscope, with transmitted light, are really siliceous, and require careful examination with the polariscope.

"I should rather infer," wrote Professor W. C. Williamson, in 1858, "that the hard shells of the Foraminifera do not constitute a sufficiently constant and important element in their organization to justify our trusting to them as guides in the discrimination of species;" and others since then have fully agreed with him, almost, if not quite, to the extent of regarding not only the Foraminifera, but even "the entire group of the Rhizopoda," incapable of *specific* division.† Still the shells have their zoological meaning; for, being variously formed by the sarcode, they refer to some processes of life and some habits of body, some peculiarities of individuals and races, which in higher and more complex animals give *specific* characters,‡ but here, unaccompanied by other fixed features of superadded parts, lose their distinctiveness among imitative repetitions, and are thus lost in changes due to the general adaptability of the sarcode creature to the varied conditions of its watery life. Certain as it is that the *shells* cannot supply grounds for *specific* distinction, yet their texture and form have the impress of the vital actions of an organism of which frequently little else is tangible; and hence they are important elements in grouping the Foraminifera. It is difficult to appreciate the physiological value of such apparent or presumed organization as is met with in the soft parts of these *Protozoa*, alive or dead, under the microscope, even when well seen; it is difficult to adjudge the relative value of the several methods of producing and using the pseudopodial or other extensions of sarcode; their modes of existence, their individual development and growth, are very imperfectly known. The differences in function and habit and mode of growth may be quite fixed in the several groups of individuals, or not: if fixed, they give *specific* characters; if interchangeable, whether by stages, by

\* See 'Proc. Belfast Nat. Hist. Field Club,' ser. 2, vol. i., pp. 87, 88.

† Williamson, 'Recent Brit. Foram.,' p. x.

‡ Professor W. C. Williamson says, "Such differences in the chemical and histological composition of these shells probably indicate correlate physiological differences in the living sarcode, or secreting animal substance, that have at least a specific value" ('Recent Brit. Foram.,' p. xii.). The same *form* of shell (as in *Cornuspira*, *Trochammina*, and *Spirillina*, for instance) being represented in the three groups (Imperforate, Arenaceous, and Perforate), should not invalidate the grounds for specific distinction unless the *structural* differences fail to hold good.



alternations, or less regularly, there is no special grouping. Observations can now be multiplied in these directions, with the help of good aquaria, towards the knowledge of Rhizopodal life.

[www.libtool.com.cn](http://www.libtool.com.cn)  
*Shells of the Imperforata.*—In the opaque shells of the *Miliolida* (see Table), an important group of the *Porcellana* or *Imperforata*, there is only one outlet for the sarcode, whether as pseudopodia, or sarcoblasts (Wallich), or as a stolon with new segmental growth. The simplest forms of their adult shells are either a mere cell-like shell (*Squamulina*), or a discoidal spiral tube (*Cornuspira*). A similar coil forms the commencement of some *Miliolæ*, which enlarge with half-turns of tubular shell (investing a wire-like sarcode, pinched at the bends), on one or three planes.\* By growing out straight, after having made a few of the alternate-sided (agathis-tegian) turns, the shell becomes a *Ceratospirulina*, linking *Miliola* with *Vertebralina*.

The tooth-like process, or obsolete septum, in the aperture, is sometimes bifid; and by extending as a cribriform plate it becomes the distinguishing feature of *Hauerina*. The inward extension of this oral network, as labyrinthic structure, characterizes *Quinqueloculina saxorum* and *Fabularia*. Another modification of the *Porcellana* is seen in the forms typified by *Orbiculina* and *Peneroplis*, towards which some flat, wide-spread *Hauerinæ* seem to lead us, whilst *Fabularia* and *Alveolina* have a similar internal structure. Further, a *Spiroloculina* (from the Orbitoidal limestone of Java) is figured by Ehrenberg,† which “is very interesting in having lateral stolons from segment to segment, showing a prolepsis of the more complicated and closely related *Orbitolites*, the outside of the quasi-annular segments being multistoloniferous. These supernumerary stolons begin by few, and become many in later segments.”‡

Dr. Carpenter states:§ “I have lately come into possession, through the kindness of M. Munier-Chalmas, of the Sorbonne Museum, of a new fossil type of Foraminiferal structure belonging to the Orbituline group, in which a partial coalescence (or subdivision) of chamberlets, like that of the lamellar portion of *Eozoon*, is very distinctly marked, so as to establish precisely the link of connection which was wanting between the chambers of *Peneroplis* and the completely divided chamberlets of *Orbiculina*.”

\* See Williamson's 'Rec. Brit. Foram.,' &c, 1858; and W. K. Parker, "On *Miliola*," 'Trans. Microscop. Soc.,' new ser., vol. vi., p. 53. Here I take the opportunity of stating that for facts and views given in this paper I am largely indebted to my friend Prof. W. K. Parker, F.R.S., with whom I have had the pleasure of working on the Foraminifera for twenty years.

† 'Transact. E. Acad. Berlin' (for 1855), 1856, pl. 4, fig. xxii.

‡ 'Annals Nat. Hist.,' Oct. 1872, p. 265.

§ 'Annals Nat. Hist.,' ser. 4, vol. xiii., p. 467.

The now nearly extinct *Dactyloporidæ* are far less evidently allied to the other *Porcellana* above mentioned, than the latter are amongst themselves. Their simplest form of shell (*Haplo-porella*), however, consists of little sacs, or bottle-shaped chambers, repeated in lateral apposition; and in more complex forms there is a structure approaching that in old *Orbitolites*.

In these points, besides the similarity of shell-tissue, the several groups of the *Porcellana* approach one another; but the *Dactyloporidæ* seem to stand somewhat apart, wanting links, hidden, perhaps lost, in the older rocks. The high-class "hyaline" *Thalamopora* reminds us of some features in the structure of *Dactylopora*.

*Shells of the Arenacea.*—The *Foraminifera arenacea* divide themselves at first sight into three sets:—1. Those which always have a sandy shell (*Lituola*, *Trochammina*, &c.); 2. Those which have a partly perforate and partly sandy shell (*Valvulina*); and 3. Those which are clear in the young and sandy in the old stages, as *Textularia* and *Bulimina*, and sometimes *Spiroloculina*, *Quinqueloculina*, and *Nubecularia*.

The persistently arenaceous forms are also divisible into two kinds:—1. Those with fine-grained sand in the shell-cement, and mostly smooth (*Trochammina*, &c.); and 2. Those with coarser grains, less cement, and a rough surface (*Lituola*, &c.). In some cases sponge-spicules are partly or wholly used in the construction of these tests. There is great difficulty, however, among the innumerable modifications of the arenaceous Foraminifers, in drawing a line between relative roughness and smoothness of shell, abundance and scarcity of cement, and coarseness and fineness of materials; and we are led from the rough lituate, to the smoother nautiloid *Lituolæ*, and on to the rotaloid *Trochamminæ*, and thence to *Valvulina*, until the whole series becomes apparently indivisible.\*

Of the rough-cast sand-shells, with a minimum of cement, *Lituola* is the leading type. It takes the well-known lituate shape; but frequently also it imitates *Lagena*, *Nodosaria*, *Orthocerina*, *Marginulina*, *Flabellina*, *Bulimina* (?), *Nonionina*, and *Globigerina* so closely that, excepting for its internal labyrinthic structure and cribrate septa, the sandy coat would seem to belong as rightfully to these as a hyaline shell. My friend, Mr. H. B. Brady, F.R.S., tells me, indeed, that it is very difficult to say whether or no the earliest (palæozoic) *Nodosariæ* had normally clear, or opaque, or sandy shells.

In his description of *Quinqueloculina fusca*,† Mr. H. B. Brady, F.R.S., points out that it differs from *Q. agglutinans*‡ in having a tough, flexible test with a very little amount of calcareous or earthy

\* Brady, 'Annals Nat. Hist.,' ser. 4, vol. x., p. 261.

† 'Annals Nat. Hist.,' ser. 4, vol. vi., pp. 276, 286.

‡ *Op. cit.*, p. 48.

constituents, although still of composite structure. Like *Globigerina* and *Orbulina*, this *Mitula* becomes less calcareous, he remarks, in brackish water. In similar degree, but under marine conditions, *Trochammina* is less arenaceous than *Lituola*.

Dr. Wallich\* remarks on the difference in test-structure between the coarse-shelled *Diffugia* and the chitonous *Arcella*, being only of subspecific value, at most, in these *Proteina*, which he places much higher among the Rhizopods than the Herpnetamous *Foraminifera*.

My friend Mr. H. B. Brady, F.R.S., states, in a letter dated December 25, 1875:

"I think I have satisfactorily settled that the dentaliniform Foraminifera from the Carboniferous rocks were all non-porous ('imperforate'),—that those from the Permian were partly true *Dentalinae* (at Byer's Quarry) and partly imperforate (at Tunstall Hill); the specimens in the latter case are larger and have much thicker shells. Many Palæozoic forms (not *Dentalinae*) are quite thin-shelled, and, to all appearance, imperforate—neither 'porcellanous' nor truly 'arenaceous.' *Endothyra* is another case in point,—thin-shelled, never porous, and subarenaceous. I believe some of these forms are really and truly the commencement of two series, differentiating, on one side, into a porous (perforate),—on the other, into a truly arenaceous (imperforate) line of organisms. The Carboniferous *Valvulina* is an analogous, smooth, imperforate species.

"*Involutina* (Liassic) has sometimes a perforate undershell, though arenaceous externally. I have some specimens beautifully perforate, but not one in a hundred of those I have worked upon. I am convinced that it runs into *Trochammina incerta* without any gap, though distinct enough in the tuberculate thickened forms. Indeed, the key to the relationship between the Arenaceous and the Perforate forms is to be found in the genera *Trochammina*, *Valvulina*, *Endothyra*, and *Textularia*. The labyrinthic condition of some *Textularia* links them with the *Lituolæ*."

On the Abrohlos Bank occur *Valvulinæ* with coarse-grained shells, and others of the usual fine-grained consistence. Whether the coarser specimens are *Lituolæ* imitating *Valvulina*, or really *Valvulinæ* with unusually coarse shells, losing their customary hyaline tissue altogether, it is difficult to say. So, on the contrary, as the older (fossil) *Buliminæ* and *Textulariæ* are sandy (*Ataxophragmium* and *Plecanium*, of Von Reuss), it may be surmised that they were at first either persistently sandy and Lituoline forms, or at most only partially "hyaline," as *Valvulina* † is now; and that they have since produced more and more hyaline shell (less and less sandy), until their successors have ceased to take up sandy materials until arriving at an adult or old stage.

Of the two gigantic arenaceous Foraminifera, *Parkeria* and *Loftusia*, it is stated that the latter, elongate and biconical, shelled with calcareous cement and fine sand-grains, has a similar relationship to *Alveolina* and *Fusulina* that *Trochammina incerta*

\* 'Annals Nat. Hist.,' March 1864.

† Some of the Cretaceous *Valvulinæ* are quite Buliminoid in aspect.

has to *Cornuspira* and *Spirillina*.\* With its great size, it has considerable labyrinthic extension of its shell walls within, as in *Lituola*. The great spherical *Parkeria* is sandy with little cement, and, beyond the nucleus of earliest chambers, its walls (highly labyrinthic and *Lituoline*) are quite concentric and enclosing, unlike any other known Foraminifer. †

In *Valvulina* we have a linking between the *Perforata* and the *Imperforata*; and if *Valvulina* leads to *Trochammina* and *Webbina*, and if these, when poor in sand-grains, are but little distinguished from *Nubecularia*, *Cornuspira*, and *Miliola* (most of which also can at times take up sand into their shellsubstance), there are evidently several points where the differentiation of the three great Foraminiferal groups is by no means absolute.

*Shells of the Perforate or Hyaline Foraminifera*.—The globular, subglobular, lageniform, and other *primordial* segments, whether simple, or divided off into a secondary semilune, are seen in the *Imperforata*, *Arenacea*, and *Perforata*. The straight, linear, or “stichostegian” growth of segments occurs in all the three groups, though rare in the first, where it is represented only by some attenuate *Articulinae* and *Spirolinae*, with obsolete *Milioline* or *Peneroplid* commencements. In the second and third groups it is common, as in *Lituolæ* and *Nodosariae*. It often occurs too as a “sport,” or wild growth, after other segmental arrangements, giving rise to “dimorphous” *Miliolæ*, *Peneroplides*, *Cristellarie*, *Polymorphinae*, *Virgulinæ*, and *Textularie*. Both *Lituola* and *Nodosaria* (theoretically straight, but often bent), are so changeable that dimorphism of curved and straight (*lituate*), or of squareness and roundness, in the same individual, is not unfrequent. The only analogous freedom from the restraint of a regular fixed line of growth among the *Globigerinida* is enjoyed by *Planorbulina*, especially in its *Truncatuline* modifications; but here a single *straight* line is never attained. The *heaping up* of chambers and chamberlets, as in *Orbitoides*, *Patellina*, *Eozoon*, and others of the *Globigerinida*, is not here in question.

The existence of “canal-system” and “intermediate skeleton” is characteristic of the higher *Rotalina*, but it has been discovered in *Planorbulina* by M. Munier-Chalmas. ‡

The simple, tubular, coiled *Cornuspira*, *Trochammina* (*T. incerta*), and *Spirillina* are scarcely distinguishable except by their shell-texture; and though some fossil (Jurassic) *Cornuspiræ* and *Trochamminæ* are so thin, and in the latter case so free from sand, as to be subtranslucent, their habit of growth distinguishes them; whilst *Spirillina* is always perforate.

*Alveolina*, *Loftusia*, and *Fusulina* represent, in the three several

\* H. B. Brady, ‘Phil. Trans.’ 1869, pp. 741 and 751.

† Carpenter, *op. cit.*, p. 728.

‡ ‘Annals Nat. Hist.’ ser. 4, vol. xiii., p. 459, note.

groups, a similar form of shell, but with considerable differences of structure.

The "agathistegian" growth of shell, so characteristic of *Miliola*, is represented in the *Perforata* by *Allomorphina* and *Chilostomella*, and among the sandy forms by *Trochammina milioloides*. On the other hand, the nautiloid, or disco-spiral, segmented growth, so characteristic of the *Perforata*, is found in *Lituola* (*L. nautiloidea* and *L. canariensis*), *Endothyra*, and *Trochammina* (*T. inflata*) of the sandy group; but it is only approached in the *Imperforata* by *Hauerina* and *Dendritina*. The *Orbiculinida* (porcellanous) correspond, in annular and subdivided chambers, with *Heterostegina*, *Cycloclypeus*, &c. (hyaline).

The alternate arrangement of chambers, seen so frequently in the *Hyalina*, is less common (*Valvulina*) in the *Arenacea* (unless we include the sandy *Textulariæ* and *Buliminæ*), and does not appear among the *Porcellana*.

Thus we see some general features of resemblance between all the three great groups, in the style of growth and arrangement of the segments, as represented by the shell; and occasionally still more binding links, such as the passage from the *Perforate* through *Valvulina* and its arenaceous allies to the *Imperforate* group. We also see very close kinship between some of the so-called "families," and decidedly among the members (so-called "genera") of these subgroups, though we have here looked at only those of the *Porcellana* and *Arenacea*, and that very cursorily. It is well known that the distinctive naming of the members of the so-called "genera" of Foraminifera almost amounts in some cases to naming the individuals themselves; and that "subgenera," "species," "subspecies," and "varieties" are terms easily applied to specimens differing less and less from a chosen type, the characters of which exist for us only in the shape, ornament, and other features of a simple shell. Doubtless the real zoological distinctions (whatever their relative value may be) are to be found in the morphology of these Microzoa: doubtless also their shells have the impress of their original and successional conditions, but these characters are obscured to a very great extent, and wait for further elucidation.

The following extract from a memoir by my friend Prof. W. K. Parker and myself, in the 'Quart. Journ. Geol. Soc.,' vol. xvi., 1860, pp. 293, 294, expresses the views on this subject we then entertained, and which we still hold, looking, however, on "species" of Foraminifera as more comprehensive, and less easily defined, the more exact our acquaintance with them becomes.

"With respect to the nomenclature adopted in our Table (of fossil and recent Foraminifera of the Mediterranean and Euxine areas, *loc. cit.*, p. 302), we have, in the first place, been careful to eliminate all unnecessary binomial terms, such as duplicate names, or names given to but slightly varied individuals; and at the same time we have enumerated many well-marked varieties in each species, because of their

value as indications of peculiar conditions of habitat; and because, many of them presenting at first sight striking differences of form, size, and ornamentation, and being easily mistaken for types of distinct specific groups, they have acquired an importance in the eyes of zoologist and geologist which makes it convenient to give them a sort of subspecific value and a binomial term.

"It has been doubted by some whether in this, the most variable, because simplest, family of the animal kingdom, every variety should not be distinguished by its own binomial appellation,—a plan that has been followed almost to the full by many naturalists. In this, however, we cannot agree, for the unlimited multiplication of quasi-specific names, linked together by pseudo-generic titles, can only weary the catalogue-maker, and throw obstacles in the way of the systematist; for it keeps up a false notion of the value of external characters which are rarely essential, whilst no clue is thereby obtained to the morphological law of each real specific type. Evidences of such law, however, are not wanting when we carefully examine varietal forms as they diverge, and, as it were, radiate, from a given central type.

"Though Linnaeus was somewhat parsimonious in giving names to the microscopic shells which he knew, and though Fichtel and Moll partially indicated their great variability, and were cautious in naming them, yet it was not until Dujardin demonstrated the nature of the Rhizopodous sarcode and its simple, non-differentiated character, and until Williamson and Carpenter, taking up the study of certain species, showed what extreme forms might be connected together by innumerable gentle intermediate gradations, that anything like a really scientific appreciation of these Microzoa may be said to have existed. Our own experience of the wide limits within which any specific group of the *Foraminifera* multiply their varietal forms, related by some peculiar conditions of growth and ornamentation, has led us to concur fully with those who regard nearly every species of *Foraminifera* as capable of adapting itself, with endless modifications of form and structure, to very different habitats in brackish and in salt water,—in the several zones of shallow, deep, and abyssal seas,—and under every climate, from the poles to the Equator. Our principles of nomenclature, and the application of them, may be seen in our papers on *Foraminifera* in the 'Annals and Mag. Nat. Hist.'

*Hyaline or Perforate Foraminifera.*—The typical shell of a "hyaline" or "perforate" Foraminifer is, in its simplest form, a very thin, calcareous, perforated tissue, as in an *Orbulina*, or in a young *Globigerina*, or in the primary segments of a *Nummulina*. In the *Lagenida* this early shell is more compact than in some other groups, but still minutely perforate. With the growth of additional segments (whether in straight, curved, or alternate arrangement), the chambers become coated, by the investing sarcode, with successive layers of shell; and the primary layer, whether soft and friable, or relatively hard and glassy, becomes thickened; its perforations, however, are usually kept continuous with the tubules in the succeeding layers by the presence of the pseudopodia, between and around which the little prism-like constituents of the simple shell are formed. According to the number of successional layers, the chamberwalls necessarily vary in thickness, either uniformly or with inequalities.

These latter originate variously; for instance, 1. From the superabundant shellmatter laid down on spots or lines, as pimples and prickles, or as thick and thin ridges, as in the *Lagenida*. 2. Thickenings over certain structures, as over the edges of septa,



as in *Cristellaria*, &c., and of margins, as in *Vaginulina*, &c. ("limbation"); or over the crossing of septa, as in scabrous *Nummulinæ*, and in umbonate *Amphisteginæ*; also in the umbilicus of *Rotalia*. 3. Local hypertrophy of the shellsubstance, with branching tubes, continued from the annular and other canals, in the thicker shells; as in the radiate processes of *Tinoporos*, in the umbones of *Polystomella*, and in the processes and umbones of *Calcarina*. 4. The outward extension of the narrow walls, or intervallation, of the tubuli, making their edges sharp and rugged, as in old *Globigerinæ*, and even prolonging them into thickets of long, thin needles, as in the acerose and hispid *Globigerinæ* and *Orbulinæ*, rivalling *Radiolaria* in their radiate growth. Other modifications of this superficial shellgrowth among the pseudopodia are seen in some *Planorbulinæ*; and the shellmatter sometimes sheaths the roots of the pseudopodia in very hirsute *Calcarinæ*, also occasionally in *Textularia* and *Planorbulina*. In an extreme degree it involves the terminal processes of sarcode in *Polymorphina horrida*; and not unfrequently makes an apertural tube, giving a pouting orifice to *Uvigerina*, &c. 5. The formation of subsidiary flaps, tentlike projections, and chamberlets for umbilical sarcode, is frequent, as in asterigerine *Discorbinæ*. Such secondary segments are neatly packed among the chambers in *Amphistegina*.\*

Endless modifications of external appearances are brought about by the various developments of these and other habits of growth; and the *extremes* produced by each kind of growth may seem at first sight to have little or no relation one to another.

The method in which the shelly coatings of successive segments meet each other,—singly, in the simple tentlike setting-on of the new chamber; doubly, with more or less continuous enwrapping of the new segment in shellmatter; or double with intermediate canaliferous substance,—does not now immediately concern us, though at the foundation of many modifications of form.

*Lagenida*.—The *Cristellarians*, whose variability we have especially to illustrate, belong to the *Lagenida*. This large group comprises, besides *Ellipsoidina*, of obscure relationship, the *Lagenæ*, the *Nodosarinæ*, and *Orthocerinæ*. *Polymorphinæ* and *Uvigerinæ* have very little distinctive character to separate them from this group.

*Lagena*.—The very common *Lagenæ* are mere flasklike shells, exquisitely delicate, presenting endless and generally elegant modifications of form. Always of simple construction, *Lagena*, nevertheless, has its surface occasionally beset with rough granules of shellmatter, and even overcast with a coating † which the outer sarcode may be said to have laid down in abortive effort to procure the "supplemental

\* The examples here offered for these inequalities of surface are not to be regarded as exhaustive.

† 'Phil. Trans.' vol. clv., p. 420, pl. 18, fig. 7.



skeleton" so highly perfected in some *Rotalina*. When elliptical in section (compressed) *Lagenæ* lose the roundness of their orifice, which becomes a slit, giving the quasi-subgeneric name of *Fissurina*. The triangular and quadrangular forms of some compressed *Lagenæ* have given rise to other such terms. *Amphorina* is a *Lagena* open at both ends. When the apertural tube is turned inwards, the shell is Entosolenian; when the tube is present and protrudes as usual, it is Ectosolenian. Some *Polymorphinæ* have an inverted tube also. The shells of *Polymorphina* and *Uvigerina* have much in common, one with another, and consist essentially of Lagenoid chambers heaped alternately, with certain habits of growth, but Lagenidal in ornament and aperture. Nor are *Bulimina* and its subgroups far removed from the same series.

*Nodosaria*, *Cristellaria*, &c.—A succession of Lagenoid chambers, in a straight line, constitutes a *Nodosaria*. The chambers being like a series of bottomless, or at least perforated, flasks, set one on another. They differ considerably in their overlap, from merely encircling the previous apertural tube, or neck, to investing the whole front of the previous chamber. The terminal aperture is either a round hole, with its border cut up into minute radial laminae, or a produced tube, sometimes lipped, and occasionally encircled, as in some *Lagenæ*, with a little spiral cord. The ornament consists essentially of either perfect or intermittent ridges of vitreous shellmatter, rarely joined by cross lines; often produced into prickles, or dying away in granules; sometimes represented by diffused granulation, and sometimes reduced to very few sharp crestlike ribs. Slight excentricity of the axis of growth, in the setting-on of the segments, often takes place, simply curving the shell (especially when it does not begin with a strong growth of relatively large and equal-sized chambers), without altering the relative position of the aperture: but this is easily shifted to one side, generally the outer or convex side of the curve, and the chambers become more or less oblique. "*Dentalina*" comprises both conditions in these usually tapering, bent *Nodosarina*. There is no straight *Nodosaria* without its more or less bent congeners; and these are associated with more and more curved individuals (*Dentalinæ*), until the early chambers are not only excentric in growth, but have a discoidal coil (*Marginulinæ*); and other associates have gone further in this style of growth, until the whole of their shell is nautiloid (*Cristellaria*). Thus the smooth *Nodosaria radricula* has *Dentalina communis*, *Marginulina subarcuatula* and *Cristellaria rotulata* as its congeneric associates or varieties; whilst the ornamented *Nodosaria raphanus*, has *D. acicula*, *M. raphanus*, and *Cr. costata* as varietal associates. *N. radricula* and *N. raphanus*, moreover, are so closely linked by graduated individuals, that they are really but varieties of one species of *Nodosarina*.

As *Lagena*, so *Nodosaria* occurs in a compressed form, and is then known as *Lingulina*; and this bent and partially coiled is *Lingulinopsis*. A *Lingula* much outspread on each side, by the overreaching of the chambers, in stretching backwards, becomes a *Frondicularia*; and if this has an excentric or coiled beginning it is a *Flabellina*, which, without the backward lateral stretch of its later chambers, would be a simple flat *Cristellaria* (*Planularia*). If a *Frondicularia* ceases to have outspread chambers, and grows on as a *Nodosaria*, it is *Amphimorphina*.

A flattened *Dentalina*, with oblique chambers, is *Vaginulina*; and if the aperture be a rift along the front of the chamber, instead of a round hole at the margin, it is *Rimulina*; and a *Vaginulina* with coiled commencement is either nearly or quite a *Marginulina*, which without its straighter portion is a *Cristellaria*.

Trigonal or quadrilateral *Nodosariæ*, known as *Orthocerinæ*, usually have a thick shell; but some take on a *Nodosarian* or *Dentaline* growth in advanced age, and are then termed *Dentalinopsis*. Their relationship is indicated by this style of growth; *Cristellarisæ*, *Marginulinæ*, and *Vaginulinæ* have the same habit.

Infinite gradations of form connect the "genera" and "subgenera" enumerated above; and the same habit of ornamentation obtains throughout, namely, ridges and riblets, often broken up into prickles, or dying away in granules. In the subdiscoidal and the nautiloid forms a marginal, and often a single dorsal, crest is the reduced, or concentrated, representative of the ridge ornament. The thickening of the septal edges, and of the umbones, is frequent and extremely variable. Lastly, the relative size and proportion of the segments (and consequently their shape in coiled shells) produce some of the greatest differences in the aspect of *Nodosarine* and especially *Cristellarian* shells. This variability in the size of the chambers in closely allied individuals seems to rest on the peculiar habits of the animal,—its well- or ill-fed condition, its freedom of growth, and such like; and, if the chambered segments are specially connected with the reproductive processes,\* other reasons for relative difference of size may exist; but the gradational conditions are such as to preclude any idea of the proportional size of chamber being a *specific* character.

*Cristellaridea*.—The many "trivial" names and binomial appellations given to *Cristellarians* (as indeed to all other congeneric *Foraminifera*) have been sore troubles to the cataloguist, though of some little use to the collector, and even to the palæontologist, in recognizing the individual kinds of *Microzoa*, which differ so much in external appearance. In reducing them, however, to zoological order, to which mere external aspect is not the chief

\* As Mr. Carter suggests for *Operculina*, 'Annals Nat. Hist.,' ser. 4, vol. xiv., 1875, p. 423.

guide, such a multiplicity of names is a stumbling-block, or at least useless. How the *Cristellarians* have fared in books, the following Table will show, and at the same time it will help us to fix the few rightful names which the chief varieties can claim, and whereby they may be referred to as recognized typical forms. By "*Cristellarians*" I mean the more or less coiled varieties of *Nodosarina raphanus* (taking that as the type species), and admitting a limited use of binomial appellations for these varieties.

In the following Table of the bibliography of the *Cristellaridea* from the time of Linné to 1841, a great number of the most important recent and fossil forms of this group are noticed. The range of selected forms takes us from well-developed *Marginulinæ* to *Planulariæ*. Multitudes, however, of weak or merely Dentaline *Marginulinæ* are passed unnoticed. The "*Robulina*" of authors is merged with *Cristellaria* on account of the interchangeableness of the character of aperture in nearly all the nautiloid varieties; as may be seen in some of the best figures given by D'Orbigny, Reuss, and others, the two kinds of aperture are merged in one. Indeed, Dr. Carpenter has of late years found that both the round, radiate aperture and the triangular orifice exist together in some *Cristellaris* from the deep Atlantic.

*Gradations of the Cristellaridea.*—Taking up the partially coiled *Nodosarinæ* (*Marginulinæ*), leading from *Nodosaria* to *Cristellaria*, we find that *Marginulina Webbiana*, D'Orb., *Cristellaria subarcuatula* (W. and J.), and *Cr. gibba*, D'O., are examples of such gradation of form. Various specimens with different degrees of ornamentation have been figured, described, and named. *Cr. rotulata* is the simple, completely discoidal form. Smooth, it is *lævigatula* (W. and J.); subumbonate, *depressula* (Montagu); limbate and umbonate, *querelans* (De M.); limbate and tuberculate, *tuberculata* and *elegans*, D'O. With but few chambers (necessarily triangular), and limbate, it is *virgata*, D'O. If thick and opening out transversely it becomes *Italica*, DeFr., *navicula*, D'O., &c., and is liable like others to grow on straightwise and become elongate.

If the simple *Cristellaria* has a marginal ridge, keel, or crest, it is *cultrata* (De M.); large-chambered and umbonate, *cassidata* (De M.); limbate with beads (or granulate on the septa), *papillosa* (F. and M.). If swollen, *cultrata* becomes *acutauricularis* (F. and M.), a large and keeled *Italica*. If the *cultrate* form has many small chambers, it is *carinata*, D'O.; if the many chambers be much curved and rather vorticial, we have D'Orbigny's (*Robulina*) *Soldanii* (his *Crist. Soldanii* is a smooth, limbate *cassis*); if the chambers be very close set, falciform, and vorticial, we have *vortex* (F. and M.), and *orbicularis* and *imperatoria*, D'O., according to the amount of keel and umbones. When the *Cristellaria* retains the

SYNOPTICAL TABLE, SHOWING IN CHRONOLOGICAL ARRANGEMENT, AS NOTICED BY THE EARLIER AUTHORS, THE VARIETAL MODIFICATIONS OF CRISTELLARIA CALCAR (LINN.); WHETHER KEELLESS, KEELED, ROWELLED, OUTSPREAD, TRIHEDRAL, OR ELONGATE.

1735-67. LINNÉ. 'Systema Naturæ,' edit. 12, 1767. p. 1162, No. 274	.. .. . Nautilus calcar, L.	.. .. .	Combining the subtypes <i>C. rotulata</i> , <i>cultrata</i> , <i>calcar</i> , and <i>cassis</i> ; after the figures given by Plineus, Gualtherus, Ledermüller, and Martinus. (See 'Annals Nat. Hist.,' ser. 3, vol. iii. p. 476.)
1784. WALKER AND JACOB. 'Testac. min. variora.'	p. 19, t. 3, f. 66	.. .. . Nautilus calcar, L.	.. .. . Slightly oval (produced) <i>C. cultrata</i> . ('Ann. N. Hist.,' ser. 3, vol. iv. p. 338.)
"	" f. 67	.. .. . "	The common smooth keelless form; the same as <i>C. rotulata</i> (Lam.), which is the best known name.
p. 20, t. 3, f. 72	.. .. . "	.. .. . <i>levigatulus</i> , W. & J.	Young few-chambered <i>Cristellaria</i> , perhaps <i>C. italica</i> .
"	" f. 73	.. .. . "	Limbate, elongate, or marginuline <i>Cristellaria</i> ( <i>C. subarcu-</i> <i>tula</i> as adopted by Williamson 1858), limbate <i>var.</i>
1791. BATSCH. 'Sechs Kupfertafeln mit Conchylien,' &c.	t. 5, f. 14	.. .. . Nautilus (Orthoceras) harpa, B.	<i>Planularia (auris, Defrance)</i> , associated with <i>Fabellina</i> and <i>Frondicularia</i> . ('Ann. N. H.,' ser. 3, vol. xv. p. 230.)
1803-8. MONTAGU. 'Testacea Brit.'	p. 189, t. 15, f. 4; and Suppl. p. 76	Nautilus calcar, L.	Thick <i>C. cultrata</i> . ('Ann. N. Hist.,' ser. 3, vol. iii. p. 348, &c.)
"	p. 188, t. 18, f. 7, 8; and Suppl. p. 75	" <i>levigatulus</i> , W. & J.	Large and thick <i>C. rotulata</i> .
"	p. 190, and Suppl. p. 78, t. 18, f. 9	" <i>depressulus</i> (non W. & J.)	Subumbonate <i>C. rotulata</i> , subtype.
"	Suppl. p. 80, t. 19, f. 1	" <i>subarcuatulus</i> , W. & J.	Smooth marginuline or elongate <i>Cristellaria</i> . <i>C. subarcu-</i> <i>tula</i> (W. & J.)
"	p. 196 and Suppl. p. 80, t. 19, f. 3	" <i>semilitrus</i> (non Gmel.)	<i>Margulina</i> , limbate with beads; M. Wetherellii, Jones, 1854.
"	Suppl. p. 86	" <i>bicarinatus</i> , M.	Elongate or marginuline <i>Cristellaria</i> .
"	p. 195	" <i>carinatus</i> , W. & J.	See above.
1803. FICHEL AND MOILL. 'Testac. Microscop.'	p. 69, t. 11, figs. a-c	.. .. . Nautilus calcar, L.	.. .. . Keeled, rowelled, limbate, and umbonate <i>C. calcar</i> . ('Ann. N. Hist.,' ser. 3, vol. v. p. 111, &c.)
"	" " d-f	" " "	.. .. . Limbate and umbonate <i>C. cultrata</i> . Typical.

## SYNOPTICAL TABLE—continued.

p. 69, t. 11, figs. <i>g, h</i>	.. ..	Nautilus calcar, L. $\gamma$	.. ..	Keeled, rowelled, limbate with beads, and umbonate, <i>C. calcar</i> .	} <i>C. margaritacea</i> (De Montf.).
" " t. 12, " <i>i, k</i>	.. ..	" "	$\delta$ .. ..	Ditto, with small beaded umbo.	
" " " <i>a-c</i>	.. ..	" "	$\epsilon$ .. ..	Ditto, with granulate surface and narrow vortical chambers.	
" " " <i>d-f</i>	.. ..	" "	$\zeta$ .. ..	<i>C. rostrata</i> (De M.), <i>C. echinata</i> (D'O.)?	
" " " <i>g, h</i>	.. ..	" "	$\theta$ .. ..	Like $\beta$ , but deformed.	
" " " <i>i, k</i>	.. ..	" "	$\eta$ .. ..	Limbate and umbonate <i>C. rotulata</i> . <i>C. querelans</i> (De M.).	
" t. 13, " <i>a, b</i>	.. ..	" "	$\iota$ .. ..	With short rowels (no keel); limbate and umbonate <i>C. calcar</i> .	
" " " <i>c, d</i>	.. ..	" "	$\kappa$ .. ..	Like $\delta$ .	
" " " <i>e, f, g*</i>	.. ..	" "	$\lambda$ .. ..	<i>C. calcar</i> , with weak keel and short rowels.	
" " " <i>h, i, k, l</i>	.. ..	" "	$\mu$ † .. ..	Umbonate <i>C. cultrata</i> . Chambers large; last septum sunken. <i>C. cultrata</i> (De M. & D'O.).	
p. 82, t. 14, " <i>a-c</i>	.. ..	" papillosus, F. & M.	.. ..	<i>C. calcar</i> , with long rowels (no keel), and large umbones.	
p. 33, t. 2, " <i>d-i</i>	.. ..	" vortex, F. & M.	.. ..	<i>C. cultrata</i> , thick and limbate with beads. <i>C. papillosa</i> (F. & M.).	
p. 47, t. 4, figs. <i>g, h, i</i>	.. ..	" .. ..	.. ..	<i>C. vortex</i> (F. & M.). Thick; with narrow, much curved, subspirial or vortical chambers; no keel. <i>C. orbicularis</i> (D'O.) is keeled and thinner. <i>C. imperatoria</i> (D'O.) is keeled and umbonate, but thinner than Fichtel and Moll's specimen.	
p. 102, t. 18, figs. <i>g-i</i>	.. ..	" .. ..	.. ..	<i>C. costatus</i> (F. & M.). Thick, limbate, longitudinally costate, large-chambered, and subcalcarate. A subspecies, <i>C. Arminensis</i> (D'O.) is a weaker form.	
p. 107, t. 19, " <i>g-i</i>	.. ..	" .. ..	.. ..	<i>C. elongata</i> , thick, triangular <i>C. cultrata</i> with partial keel. Between <i>C. cultrata</i> and <i>C. italcia</i> (Deff.).	
p. 95, t. 17, figs. <i>a-d</i>	.. ..	" .. ..	.. ..	<i>Planularia crepidula</i> . A subspecies. <i>Pl. cymboides</i> , D'O., 'For. Fos. Vien.', is the same. Keeled forms are <i>Pl. elongata</i> , <i>lancoolata</i> , &c.	
" " " <i>e-g</i>	.. ..	" .. ..	.. ..	<i>C. cassia</i> , with beaded umbo.	
" " " <i>h, i</i>	.. ..	" .. ..	.. ..	with beaded umbo, and partly limbate with beads.	
" " " <i>k, l</i>	.. ..	" .. ..	.. ..	keel-toothed, and limbate with beads.	
" t. 18, " <i>a-c</i>	.. ..	" .. ..	.. ..	smooth (= <i>Galea</i> , F. & M. <i>subcar</i> ., and <i>C. consecta</i> , D'O.†). When <i>Flabellina</i> , <i>C. navicularis</i> (De M.).	
p. 100, " " <i>d-f</i>	.. ..	" .. ..	.. ..	with umbo slightly beaded.	
	.. ..	" .. ..	.. ..	smooth and large. <i>C. Galea</i> , F. & M. <i>subcar</i> .	

\* Fig. *g* (edge view) was taken from a much better specimen than fig. *f*.

†  $\alpha$ ,  $\theta$ ,  $\kappa$ , and  $\mu$ . These rowelled shells are comprised by D'Orbigny in his *Robulina aculeata*.

‡ Not *C. margaritacea*, as stated in the 'Ann. N. Hist.', ser. 4, vol. viii, p. 243.

- 1804-6. LAMARCK. ('Ann. Nat. Hist.,' 3 ser., vol. v. p. 286.) 'Annales du Muséum,'  
v. p. 188, and viii. p. 387, t. 62, f. 11, *Lenticulites rotulata*, Lam. *Cristellaria rotulata*. Adopted as a named variety;  
the same as Walker and Jacob's fig. 67; but the trivial name  
given by Lamarck is better known.
1807. MATON AND RACKETT. 'Linnean Soc. Transact.,' vol. viii.  
p. 114 .. .. . *Nautilus rotatus*,\* M. & B. *C. cultrata*. Montagu's t. 15, f. 4.
- 1808-10. DE MONTFORT. 'Conchyl. System.,' vol. i. ('Ann. N. H.,' ser. 3, vi. p. 339; &c.)  
p. 10, t. 3 .. .. . Phoenemus "tranchant" .. .. . *C. calcar*?  
p. 26, t. 7 .. .. . Chrysolus "perte" .. .. . *Planularia crepidula* (F. & M.)?  
p. 34, t. 9 .. .. . Pharamum margaritaceum, 3, F. & M. Above. *Cristellaria margaritacea* (De M.).  
De M.  
p. 70, t. 18 .. .. . Antenor diaphanens, De M. .. .. . *C. calcar*, typical.  
p. 94, t. 24 .. .. . Oreas subulatus, De M. .. .. . *C. acutaureicularis* (F. & M.).  
p. 214, t. 54 .. .. . Robulus cultratus, De M. .. .. .  $\lambda$ , F. & M. *C. cultrata*. Adopted by D'Orbigny as  
*Robulina*.  
p. 218, t. 55 .. .. . Patroclus querelans, De M. .. .. .  $\gamma$ , F. & M.  
p. 222, t. 56 .. .. . Sphincterules costatus, F. & M. *C. costata* (F. & M.).  
p. 226, t. 57 .. .. . Clisiphontes calcar, L. .. .. .  $\alpha$ , F. & M.  
p. 230, t. 58 .. .. . Herion rostratus, De M. .. .. .  $\epsilon$ , F. & M. See also *Cr. marginata*, D'Orb. 1826.  
p. 234, t. 59 .. .. . Rhinocurus araneosus, De M. .. .. . *C. calcar*, typical. (*C. aculeata*, D'O.)  
p. 238, t. 60 .. .. . Macroditis cucullatus, De M. .. .. . *C. cassis* without a keel? A cast?  
p. 242, t. 61 .. .. . Lampas Tritheumus, De M. .. .. .  $\zeta$ , F. and M. Deformed *C. cultrata*.  
p. 250, t. 63 .. .. . Scortium navicularis, De M. .. .. . *C. cassis*, smooth and passing into *F. labellina*. Adopted by  
D'Orbigny as *Cristellaria navicularis*.  
p. 254, t. 64 .. .. . Linthuris cassidatus, De M. .. .. .  $\beta$ , F. & M. *C. cassis*, typical.  
p. 262, t. 66 .. .. . Astacolus crepidulatus, De M. .. .. . *Planularia crepidula* (F. & M.).  
p. 270, t. 68 .. .. . Periples elongatus, De M. .. .. . *Planularia elongata* (De M.). Keel'd and serrated.  
D'Orbigny's *Cristellaria elongata* is a keel'd *Planularia*, but  
not dentate.
1816. LAMARCK. 'Tableau Encyclop. et Method.' ('Ann. N. H.,' ser. 3, vol. v. p. 287, &c.)  
t. 466, f. 5 .. .. . *Lenticulites rotulata*, Lam. *Cristellaria rotulata* (Lam.).  
t. 467, f. 3, a-d .. .. . *Cristellaria cassis*, F. & M. *C. cassis*,  $\alpha$ , F. & M.

\* Not the *N. rotatus* in Wood's 'Index Test.,' t. 13, f. 5, which is a variety of *Pulvinulina Partschiana* (D'Orb.).





- xxxii. p. 178, 1824, xli. p. 244, t. 14, f. 5, *Planularia auris*, Defr... (*Peneropis auris*, De Bl.), *Planularia auris*, Defrance.  
*Pl. cymba*, D'Orb., 1827, is a narrower form.
- xxxii. p. 177, 1824, xlvi. p. 344,  
 1827, t. 13, f. 6 . . . . . *Saracenaria Italica*, Defr.  
*C. rotulata* thickened, trihedral, and passing into *Marginitina*.  
*C. italica* (Defr.).
1822. LAMARCK. ('Ann. N. H.,' ser. 3, vol. v. p. 288, &c.) 'Anim. sans Verteb.,' vol. vii.  
 p. 607, No. 2 . . . . . *Cristallaria papillosa* (non F. & M.) *C. cassis*,  $\alpha$ ,  $\beta$ ,  $\gamma$ ,  $\epsilon$ , F. & M.  
 p. 608, No. 3 . . . . . " *C. cassis*,  $\delta$  and *galea*, F. & M.  
 p. 608, No. 4 . . . . . " *auricularis*, Lam. . . . . *C. acutauricularis* (F. & M.)  
 p. 608, No. 7 . . . . . " *crepidula* (F. & M.) *Planularia crepidula* (F. & M.)  
 p. 620, No. 8 . . . . . " *Lenticulina rotulata*, Lam. *C. rotulata* (Lam.)  
 p. 625, No. 2 . . . . . " *Polysomella costata* (F. & M.) *C. costata* (F. & M.)
1826. ALONE D'ORBIGNY. 'Ann. N. H.,' ser. 3, vol. xii. p. 429, &c.; vol. xvi. p. 15, &c.; ser. 4, vol. viii. p. 145, &c.)  
 p. 292, No. 23 . . . . . " *Cristallaria auricularis*, Lam. *C. acutauricularis* (F. & M.)  
 p. 290, No. 3, Modèles 44 and 83 . . . . . " *cassis* (F. & M.) Including var.  $\beta$  &  $\epsilon$  (subglobelline).  
 p. 291, No. 6 . . . . . " *Galea* (F. & M.) *C. galea* (F. & M.)  
 p. 293, No. 26, Modèles 19 and 85 . . . . . " *italica* (Defr.) *C. italica* (Defr.)  
 p. 260, No. 5 . . . . . " *Planularia auris*, Defr. *Planularia auris*, Defr.  
 p. 260, No. 6 . . . . . " *crepidula* (F. & M.) *Pl. elongata*, D'O. Keeled.  
 p. 269, No. 12 . . . . . " *Robulina calcar* (L.) *Crist. calcar* (L.) Includes keeled, rowelled, and *granu-*  
*late* form (*papillosa*, D'O.), non F. & M., nec Lam. Includes  
 var.  $\epsilon$ , F. & M. *C. rostrata* (De M.). *C. echinata* (D'O.)?  
 p. 269, No. 13 . . . . . " *costata* (F. & M.) *C. costata* (F. & M.)  
 p. 267, No. 1, Modèle 82 . . . . . " *cultrata* (De M.) *C. cultrata* (De M.)  
 p. 268, No. 4 . . . . . " *vortex* (F. & M.) *C. vortex* (F. & M.)  
 p. 269, No. 14 . . . . . " *aculeata*, D'O. . . . . *C. calcar* (L.) Vars.  $\alpha$ ,  $\theta$ ,  $\kappa$ ,  $\mu$ , F. & M. Typical *C. calcar*.  
*C. araneosa* (De M.)  
 p. 268, No. 2, t. 15, f. 8, 9\* . . . . . " *orbicularis*, D'O. Keeled and umbonate, sometimes slightly.  
 p. 260, No. 4, t. 10, f. 9, Modèle 27 *Planularia cymba*, D'O. Small *Planularia auris*, Defr.  
 p. 290, No. 17, Modèle 14 . . . . . " *Robulina virgata*, D'O. *C. virgata*, D'O. Strongly limbate and umbonate; with few triangular chambers; keelless.  
 p. 292, No. 19, Modèle 47 . . . . . " *Oristellaria levigata*, D'O. *C. levigata*, D'O. (Jurassic). Elongate, umbonate, and partially limbate. Umbonate *C. subarcuatula*, or *C. rotulata* passing into *Marginitina*.

## SYNOPTICAL TABLE—continued.

p. 292, No. 10, Modèle 84	..	..	Cristellaria costata, D'O. ( <i>non</i> F. & M.)	Small or young <i>Planularia auris</i> , Defr.
p. 260, No. 7	..	..	<i>Planularia rostrata</i> , D'O.	Keelcd and mucronate <i>Pl. cymba</i> , D'O. (var. of <i>Pl. crepidula</i> ).
p. 288, No. 5	..	..	<i>Robulina Soldanii</i> , D'O.	<i>C. cultrata</i> , with rather vorticial chambers, intermediate to <i>C. costata</i> . <i>C. Soldanii</i> (D'O.).
p. 288, No. 6	..	..	" <i>marginata</i> , D'O.	<i>C. cassis</i> (F. & M.). Young.
p. 288, No. 7	..	..	" <i>radinata</i> , D'O.	<i>C. calcar</i> (L.). Small.
p. 288, No. 8	..	..	" <i>pulehella</i> , D'O.	<i>C. calcar</i> (L.).
p. 288, No. 9	..	..	" <i>levigata</i> , D'O.	<i>C. calcar</i> (L.). Keel partial or broken.
p. 289, No. 11	..	..	" <i>rosacea</i> , D'O.	<i>C. calcar</i> (L.), with rose-ornament on umbo. <i>C. rosacea</i> (D'O.).
p. 290, No. 23	..	..	" <i>plicata</i> , D'O.	<i>Cristellaria</i> . Keelless. A cast?
p. 290, No. 24	..	..	" <i>rotundata</i> , D'O.	<i>C. calcar</i> (L.). Keel partial.
p. 290, No. 1	..	..	<i>Cristellaria consecta</i> , D'O.	<i>C. cassis</i> (smooth), var. ♂, F. & M. = <i>C. galea</i> (F. & M.).
p. 290, No. 2	..	..	" <i>navicularis</i> (De M.).	<i>C. cassis</i> , smooth, like the last; and <i>Flabellina</i> (growing like <i>Flabellina</i> ).
p. 289, No. 15	..	..	" <i>ariminensis</i> , D'O.	<i>C. costata</i> (F. & M.). Subvariety with sunken sutures.
p. 281, No. 1	..	..	<i>Soldania carinata</i> , D'O.	<i>C. ariminensis</i> , D'O.
p. 290, No. 4	..	..	<i>Cristellaria Soldanii</i> , D'O.	Small-chambered <i>C. cultrata</i> . <i>C. carinata</i> (D'O.).
p. 291, No. 4	..	..	" <i>nitida</i> , D'O.	<i>C. cassis</i> , smooth and limbate.
p. 291, No. 7	..	..	" <i>marginata</i> , D'O.	<i>C. cassis</i> (= var. ♀, F. & M.). Intermediate to <i>C. cassis</i> and <i>C. calcar</i> .
p. 293, No. 25	..	..	" <i>pepillosa</i> , D'O. ( <i>non</i> F. & M., <i>nee</i> Lam.)	<i>C. calcar</i> (L.). Keelcd and rowelled; surface granulate; chambers hidden. Near <i>C. rostrata</i> (De M.).
p. 292, No. 11	..	..	" <i>elongata</i> (De M.)*	<i>C. calcar</i> (L.). Rowelled and granulate; chambers broad.
p. 292, No. 12	..	..	" <i>bilobata</i> , D'O.	<i>C. marginata</i> , D'O.
p. 292, No. 21	..	..	" <i>tuberculata</i> , D'O.	Keelcd. <i>Planularia elongata</i> (De M.).
p. 293, No. 24	..	..	" <i>elegans</i> , D'O.	<i>Planularia elongata</i> with two-toothed apex.
p. 292, No. 17, For. Cub. 1839, p. 63, t. 7, f. 20, 21.	..	..	" <i>gibba</i> , D'O.	Keelless <i>Cristellaria</i> , strongly limbate and tuberculata. <i>C. tuberculata</i> D'O.
				<i>C. tuberculata</i> , weak in limbation and umbonal growth.
				Produced <i>C. rotulata</i> . <i>C. gibba</i> , D'O.

\* De Montfort refers to the figure (b b) in Soldani which D'Orbigny includes in his reference.



## SYNOPTICAL TABLE—continued.

p. 127, t. 1, figs. 14, 15	.. ..	Cristellaria Berthelotiana, D'O.	Flatter than <i>Marginulina Webbiana</i> : almost <i>Planularia crepidula</i> . Planularian <i>Cristellaria</i> , near Montagu's t. 19, f. 1, and the same as Williamson's fig. 56, grouped together as <i>C. subarcuata</i> (W. & J.).
p. 126, t. 3, " 7-9	.. ..	Sauleyi, D'O.	Limbate <i>C. rotulata</i> passing into smooth <i>Marginulina</i> . The same as <i>C. lævigata</i> , D'O. (Osen Oolite), Model 47.
p. 127, t. 3, " 3, 4	.. ..	Robulina Canariensis, D'O.	<i>C. cultrata</i> , umbonate.
1859. A. D'ORBIGNY. 'Foram. de l'Amér. mérid.'	.. ..	Robulina subcultrata, D'O.	Umbonate <i>C. cultrata</i> , with sunken sutures (" <i>R. cultrata</i> " in the plate.)
p. 26, t. 5, figs. 19, 20	.. ..	Robulina subcultrata, D'O.	
1859. A. D'ORBIGNY. 'Foram. de Cuba.'	.. ..	<i>Cristellaria gibba</i> , D'O.	<i>C. rotulata</i> , with sunken sutures, and becoming elongate.
figs. 20, 21	.. ..	<i>Cristellaria crepidula</i> , (F. & M.)	Planularia crepidula (F. & M.). Above.
" 17, 18	.. ..		
1840. AL. D'ORBIGNY. 'Mém. Foram. Craie blanche.'	.. ..		
figs. 15-18	.. ..	<i>Cristellaria rotulata</i> , Lam.	<i>C. rotulata</i> : umbonate, figs. 17, 18; not umbonate, f. 19.
f. 19, 20	.. ..	" <i>navicula</i> , D'O.	Elongate, thick <i>C. rotulata</i> . <i>C. Italica</i> (Defr.).
" 21, 22	.. ..	" <i>triangularis</i> , D'O.	Trihedral <i>C. rotulata</i> .
" 23-25	.. ..	" <i>recta</i> , D'O.	Very narrow elongate <i>C. rotulata</i> ; or narrow, thickish <i>Planularia</i> .
" 26, 27	.. ..	Gaudryana, D'O.	Young <i>Flabellina</i> ; or Flabelline limbate <i>Planularia</i> .
1840-1. F. A. RÖMER. 'Verstein. Norddeutsch. Kreidegeb.'	.. ..	Planularia Bronni, R.	Thick, simple Marginuline (produced) <i>Cristellaria</i> . Thick <i>C. subarcuata</i> ; or thick, short <i>Marginulina Webbiana</i> , D'O., or <i>glabra</i> , D'O.
f. 14	.. ..		
f. 15	.. ..	<i>Marginulina comma</i> , R.	with sunken sutures.
f. 80	.. ..	<i>Robulina Muensteri</i> , R.	<i>C. cultrata</i> (De M.).
f. 81	.. ..	" <i>Ehrenbergii</i> , R.	<i>C. cultrata</i> ?
f. 32	.. ..	" <i>crassa</i> , R.	Umbonate <i>C. rotulata</i> (Lam.).
f. 33	.. ..	" <i>Comptoni</i> , Sow.	Umbonate <i>C. rotulata</i> (Lam.).
f. 34	.. ..	" <i>Nonionina compressa</i> , R.	<i>C. rotulata</i> ?

longitudinal ribbing of *Nod. raphanus*, we have the thick *costata* (F. and M.), and the weaker *ariminensis*, D'O. In *C. ornata*, D'O., this ornament is dying out.

An excessive crest, accompanied with thinness (compression) of the chambers, gives rise to the large and elegant *Crist. cassis* and its subvarieties.

When the keel is subdivided into spines, like the rowels of a spur, *cultrata* becomes *calcar* (Lin.); and *margaritacea*, *rosacea*, *rostrata*, and *marginata* are among the names given to subvarieties. Granules on umbones and septa, or all over, are frequent in the subvarieties of *C. calcar* and *C. cassis*.

Some of the above-mentioned features and conditions are evidently gradational; the others are related by many similar gradations not here mentioned, but some of which are indicated in the Table.

The long, flat *Cristellarix*, retaining something of the *Marginulina* growth, but with the posterior or downward angle of the chambers reaching almost or quite down to the excentric umbilicus, are known as *Planularix*, very delicate and pretty shells. *Pl. crepidula* (F. and M.) is little more than a *Marginulina* and rather less than a *Cristellaria* of the *rotulata* group, but thin and imperfectly coiled; its modifications are endless; when keeled, it is *elongata*, D'O.; *rostrata*, D'O., when mucronate also. With bolder convexity and better development of the apertural margin, with more numerous and neater chambers, and some trace of costate ornament, we have *Pl. auris*,\* DeFrance, and its smaller forms *cymba* and *auricula*, D'O.

*Conclusion.*—Without having exhausted the subject, I think that these remarks may be usefully suggestive to beginners and students. One good piece of work that promises satisfactory results would be the careful copying and collating of all the figured forms of each "genus" and "species" of Foraminifera, so that their gradations and their distinctions might be seen at a glance, and the right appellation, according to priority and worth, be awarded to the types and subtypes. These appear to have come from very early times, increasing their varieties under every new set of modifying conditions to which they were introduced. These varieties have sufficient fixedness to give a peculiar *facies* to the several local groups of Foraminifera, fossil or recent; and, insomuch, their chief forms require a nomenclature for reference and identification.

The remarkable persistence of Foraminiferal types, in general character, has been often noticed; and their conservative tendencies, due to their simplicity and universal adaptability, has been com-

\* Batsch figured this shell, together with *Fronicularia* and *Flabellina*, calling them all *Nautilus harpa*, an appropriate name, had he defined the separate form.

pared with the susceptibility of living on under very various conditions, shown by man, the dog, &c., but, of course, the terms of comparison are not really equal. The extreme variability of Foraminifera, of both great groups (Porcellanous and Vitreous), is doubtless governed by some systematic life-properties which we do not at present recognize in their totality. A wide field for research opens here. As far as we can see at present, as far as we understand the nature and growth of these Microzoa, there seem to be but relatively few links wanting to make the gradations, from one group to another, in form and structure, so evident and so close that all the Foraminifera might be placed in the close union of a specific group, modified by conditions of habitat, feeding, climate, and hereditary peculiarities of growth. But I am not yet prepared to avow a belief in their unispecific relationship.

*Remarks on the Cristellarians figured in Plates CXXVIII. and CXXIX. in illustration of their Variability of Form and Ornament.*

Taking examples, as much as possible, from among contemporaneous and local groups, we have the associated forms, whether varying from an original stock by long series of differences, in collateral races, or showing new varieties, resulting from the peculiar conditions of place and time.

The beautiful illustrations of Herr Max von Hantken's Monograph\* on the Foraminifera of those Tertiary strata in Central Hungary, which he terms the "Clavulina † Szabói-beds," supply us with a fine series of variations of well-known forms from one geological deposit.

Alcide D'Orbigny's Monograph on the Tertiary Foraminifera of Vienna, known to all Rhizopodists, has also been applied to for some good typical forms. Thirdly, the Liassic and Lower Oolitic Foraminifera, with their innumerable variations of *Nodosarinæ*, illustrated by M. O. Terquem and Mr. H. B. Brady, F.R.S., supply us with two sets of Rhizopods living about the same time and having similar developments.

The few figures taken from the reduced outlines of some of Soldani's illustrated Italian Tertiary (Pliocene) Foraminifera, belong to forms not very far removed in time from those figured by D'Orbigny and Von Hantken (Miocene).

Fig. 1 (Pl. CXXVIII.) is one of the simplest forms of *Nodosarina* (*Nodosaria* proper). In Fig. 2 it is no longer quite straight, but

\* From the 'Mittheilungen aus dem Jahrbuche der kön. ung. geologischen Anstalt,' vol. iv., 8vo. Budapest, 1875.

† The term *Clavulina* is here applied to the elongated *Tritaxia* (Reuse), or dimorphous *Verneulinina*, D'Orb., allied to *Clavulina communis*, D'Orb.

is a *Dentalina* with excentric orifice.\* In Figs. 3 and 4 it has lost more and more of its bilateral symmetry, becoming a *Marginulina*; and its curvature becomes extreme and discoidal in Fig. 5. Here the newest chamber is still simple, but the older part of the shell has received a crest or keel—essentially a single, medial riblet. Returning to the bent form of *Nodosaria*, in Figs. 6, 7, and 8, we have stronger, neater, and more compact *Marginulinæ*; the last one with a crest. By the transverse lengthening and obliquity of the chambers, with corresponding lateral compression, we are led to Figs. 9, 10, and 11, which end in the flat form of elongated *Cristellaria*, termed *Planularia*; whose close relation to the discoidal type is beautifully shown by Fig. 12.

The coiling of early chambers (as in Fig. 7) is often succeeded, not by linear, but by continued spiral growth (*Cristellaria*), leading ultimately to Figs. 13, 14, 15, and 16, with their various conditions of keel, limbation, and umbones, and very changeable proportions (and hence shape) of their chambers, see Pl. CXXIX., Figs. 18 and 19, besides the more ornamented forms. Fig. 17 is another ultimate *Cristellaria* of the same breed; but Fig. 18 has still an elongate shape, leading, on one hand, to the nearly discoidal, but arrested, Fig. 19; and, on the other, to the very thick forms (Figs. 20 and 21), which are known as DeFrance's *Saracenaria Italica*.

Referring to Fig. 1, we lose its roundness in the flatter Fig. 22 (*Langulina*). The chambers, beginning to overlap at the edges in Fig. 23, become chevron-shaped in Fig. 24 (*Frondicularia*). Even in Fig. 23, however, the early chambers are not simply linear in growth, and this, increased in Fig. 24 to a subspiral arrangement, leads through many gradations in these flat shells to a spiral system of early chambers, as seen in Figs. 25 and 26; and this Planularian growth remains free, without the overriding or saddle-like chambers, in Fig. 27, essentially the same as Fig. 10 and its allies, and, excepting its relative thinness, equivalent to Fig. 18, &c. One of its ornamented colocal varieties is shown in Pl. CXXIX., Fig. 12.

Plate CXXIX. exhibits some of the ornamented analogues of the above-mentioned varietal forms of *Nodosarina*. Fig. 1a is a *Nodosaria* with characteristic ornamental ridges, but they end abruptly on each chamber, forming little spikes. In Fig. 1b several small spines or prickles are produced on each ridge or riblet of the chambers of a slightly bent (*Dentaline*) *Nodosaria*.

In Figs. 2-6 the riblets are represented by granules on some allied *Marginulinæ*.† In some individuals (as in fig. 1, pl. 6, of Von Hantken's Monograph) they become gradually confined to the

\* If the shell were flattened it would be a *Vaginulina*.

† *Marginulina Wetherellii* of the London Clay is the same form.



septal lines; they are often wanting on the newer chambers of the shell. In the further developed *Cristellaria*, Fig. 6, the granulated septal lines continue the above-described character; and in Fig. 7 the aspersions of shellmatter in the form of pimples or granules over all the older portion of the shell is a character fore-shown by the somewhat irregular granulation in some specimens of *Marginulina fragaria* (*Wetherellii*), and in the grouped granules on the umbo of Fig. 7. Soldani figured several highly granulate *Cristellarisæ* of this kind.\*

Fig. 8 is the common and variable *Nodosaria raphanus*, with characteristic ribbing; Fig. 9 is its *Marginulina*, individuals of which present gradual (though rare) passages to *Cristellaria costata* (F. and M.) and its feeble representative, Fig. 10. The flat form of *N. raphanus* is *Lingulina costata*, D'Orb., Fig. 11; and its *Flabellina* (Fig. 17) is *Fl. striata*, Hantken.

Taking up Fig. 12 again, referred to above, we see its further development in its colocal ally, Fig. 13, which may be said either to fade away into, or to have come from, the *Vaginulina*, Fig. 14, which is the flat asymmetrical, one-sided form of *Nodosaria raphanus*. Fig. 15, one of the delicately elegant, flat *Cristellarisæ* (*Planularisæ*), is related by gradation to Fig. 11, &c., in Pl. CXXVIII., and wears the usual costulate ornament of the *Nodosarinæ*. One of its extreme forms is shown in Fig. 16.

Fig. 18 is an explanate, broadly spiral *Cristellaria* (*C. cassis*, F. and M.), putting on overriding chambers, and thus becoming *Flabellina*, like Figs. 25 and 26, Pl. CXXVIII., and thousands of similar and analogous varieties. Fig. 19, a *Cristellaria*, with very narrow, curved, vorticial chambers, has been already noticed.

Besides the above selections, very many others might easily be made. Thus, in Von Reuss's beautiful plates of the Foraminifera of the Westphalian Chalk,† the following might be arranged in succession:—Pl. 4, f. 1; pl. 3, f. 6; pl. 2, f. 8; and pl. 1, f. 5; pl. 5, f. 6; pl. 7, f. 4; and pl. 6, f. 5: also pl. 7, f. 3, 5; pl. 5, f. 7; pl. 8, f. 6; pl. 9, f. 4; pl. 10, f. 3, 4, 1. In Von Reuss's Memoir‡ on the 'Tertiären Foraminiferen-Fauna,' &c., the following series may be studied:—Pl. 3, f. 30, 36, 33, 37, 39; pl. 4, f. 47, 49, 50, 53, 54; pl. 5, f. 59, 65. From f. 53 to pl. 5, f. 62; pl. 6, f. 68; and pl. 8, f. 91. From f. 59 to pl. 6, f. 63, 64, and 66. Hundreds of other gradational figures may easily be selected, but the above are sufficient.

\* See 'Annals Nat. Hist.,' ser. 4, vol. viii., pl. 10 and 11, figs. 96-99, &c.

† Sitzungsber. math.-nat. Cl. k. Akad., Wiss. Wien, vol. xl., 1860.

‡ *Op. cit.*, vol. xlviii., 1863.

I. FORAMINIFERA IMPERFORATA VEL PORCELLANA.

I. NUBECULARIDA.

Squamulina, Schultze. Monothalamous.  
Nubecularia, DeFrance. Fixed.

II. MILIOLIDA.

Vertebralina, D'Orb. Dimorphous usually.  
a. Articulina, D'Orb. Dimorphous.  
Cornuspira, Schultze (restricted). Monothalamous.  
Miliola, Lamarck.  
a. Uniloculina, D'Orb. Monothalamous.  
b. Biloculina, D'Orb.  
c. Triloculina, D'Orb.  
d. Quinqueloculina, D'Orb.  
e. Cruciloculina, D'Orb.  
f. Spiroloculina, D'Orb.  
g. Ceratospirulina, Ehrenberg. Dimorphous.  
Hauerina, D'Orb.  
Fabularia, DeFrance.

III. PENEROPLIDA.

Peneroplis, De Montfort.  
a. Spirolina, Lamarck (restricted). Dimorphous.  
b. Dendritina, D'Orb.

IV. ORBICULINIDA.

Orbiculina, Lamarck.  
Orbitolites, Lamarck.  
a. Pavonia, D'Orb.  
Alveolina, D'Orb.

V. DACTYLOPORIDA.

Haploporella, Gümbel.  
Dactyloporella, Gümb. (*Dactylopora auctorum in parte*).  
Thyrsoporella, Gümb.  
Grypoporella, Gümb.  
Cylindrella, Gümb.  
Uteria, Michelin.  
Acicularia, D'Archiac.  
Verticillipora (?), Mantell.  
Receptaculites, DeFrance.  
Archæocyathus, Billings.

II. FORAMINIFERA ARENACEA.

I. PARKERIADA.

Parkeria, Carpenter.  
Loftusia, Brady.

II. LITUOLIDA.

Endothyra, Phillips.  
Involutina, Terquem.  
Trochammina, Parker and Jones. Monothalamous in some forms.  
a. Webbina, D'Orb. (restricted). Fixed.  
Valvulina, D'Orb. Sometimes dimorphous.  
Tetrataxis, Ehrenberg.  
Ataxophragmium, Reuss (sandy *Bulimina*).  
Plecanium, Reuss (sandy *Textularia*).

- Saccamina, Sars. Monothalamous in one form.  
 a. Psammosphæra, F. E. Schulze. Monothalamous?  
 b. Storthosphæra, F. E. Schulze. Monothalamous.  
 Pilulina, Carpenter.\* Monothalamous.  
 Astrobhiza, Sandahl. Monothalamous.  
 a. Astrodiscus, F. E. Schulze. Monothalamous.  
 Rhabdammina, Carpenter. Monothalamous?  
 Botellina, Carpenter. Monothalamous.  
 Proteonina, Williamson. Monothalamous?  
 Lituola, Lamarck. Often dimorphous.  
 a. Placopsilina, D'Orb. Fixed.  
 b. Haplophragmium, Reuss. Often dimorphous.  
 c. Haplostiche, Reuss.  
 d. Hippocrepeina, Parker.  
 e. Polyphragma, Reuss.  
 f. Conulina (?), D'Orb.

### III. FORAMINIFERA PERFORATA VEL HYALINA.

#### I. LAGENIDA.

- Ellipsoidina, Seguenza.  
 Lagena, Walker and Jacob. Monothalamous.  
 a. Entosolenia, Ehrenberg.  
 b. Fissurina, Reuss.  
 Ramulina, Jones. Slightly segmented, branching.  
 Nodosarina, Parker and Jones.  
 a. Glandulina, D'Orb.  
 b. Nodosaria, Lamarck.  
 c. Dentalina, D'Orb.  
 d. Lingulina, D'Orb.  
 e. Lingulinopsis, Reuss. Dimorphous.  
 f. Rimulina, D'Orb.  
 g. Vaginulina, D'Orb. Dimorphous usually.  
 h. Marginulina, D'Orb. Dimorphous.  
 i. Psecadium, Reuss. Dimorphous.  
 j. Cristellaria, Lamk. Sometimes dimorphous.  
 k. Planularia, DeFr.  
 l. Flabellina, D'Orb. Dimorphous.  
 m. Frondicularia, DeFrance.  
 n. Amphimorphina, Neugeb. Dimorphous.  
 Orthocerina, D'Orb.  
 a. Dentalinopsis, Reuss. Dimorphous.

#### II. POLYMORPHINIDA.†

- Polymorphina, D'Orb.  
 a. Dimorphina, D'Orb. (restricted). Dimorphous.  
 Uvigerina, D'Orb.  
 a. Sagrina, D'Orb. (restricted). Dimorphous.

#### III. BULMINIDA.

- Bulimina, D'Orb.  
 a. Ataxophragmium (sandy), Reuss.  
 b. Bolivina, D'Orb.

\* For this and some other allied forms, see Dr. Carpenter's 'Descriptive Catalogue of Objects from Deep-sea Dredgings exhibited at the Soirée of the Royal Microscopical Society, King's College, April 20th, 1870.' 8vo. London, 1870.

† The *Polymorphinida* are separated from the *Lagenida* only on account of their *alternite* arrangement of chambers.

- c. *Virgulina*, D'Orb.
- d. *Bifarina*, P. and J. Dimorphous.
- e. *Robertina*, D'Orb.
- Cassidulina, D'Orb.
- a. *Ehrenbergina*, Reuss. Dimorphous.

#### IV. TEXTULARIDA.

- Textularia*, DeFrance.
- a. *Plecanium* (sandy), Reuss.
  - b. *Bigenerina*, D'Orb. Dimorphous.
  - c. *Spiroplecta*, Ehrenb. Dimorphous.
  - d. *Gaudryina*, D'Orb. Dimorphous.
  - e. *Verneuilina*, D'Orb.
  - f. *Tritaxia*, Reuss. Dimorphous.
  - g. *Clavulina*, D'Orb. (restricted). Dimorphous.
  - h. *Heterostomella*, Reuss. Dimorphous.
  - i. *Vulvulina*, D'Orb.
  - j. *Venilina*, Gumbel. Dimorphous.
  - k. *Candaina*, D'Orb.
  - l. *Cuneolina*, D'Orb.

#### V. GLOBIGERINIDA.

##### (1.) *Globigerinina*.

- Orbulites*, Lamarck. Monothalamous.
- Orbulina*, D'Orb. Monothalamous usually.
- Globigerina*, D'Orb.
- Pullenia*, Parker and Jones.
- Sphaeroidina*, D'Orb.
- Carpenteria*, Gray. Fixed.
- Allomonina*, Reuss.\*
- Chilostomella*, Reuss.\*

##### (2.) *Rotalina*.

- Spirillina*, Ehrenb. (restricted). Monothalamous.
- Discorbina*, Parker and Jones.
- Planorbulina*, D'Orb. Fixed in some cases.
- a. *Planulina*, D'Orb.
- b. *Truncatulina*, D'Orb. Fixed.
- Pulvinulina*, Parker and Jones.
- Rotalia*, Lamarck (restricted).
- Cymbalopora*, Von Hagenow.
- Thalamopora*, Reuss.
- Calcarina*, D'Orb.
- Tinoporus*, De Montfort (restricted).
- Patellina*, Williamson.
- Conulites*, Carter.
- Polytrema*, Risso. Fixed.

##### (3.) *Polystomellina*.

- Polystomella*, Lamarck (restricted).
- a. *Nonionina*, D'Orb.

##### (4.) *Nummulinina*.

- Nummulina*, D'Orb.
- a. *Operculina*, D'Orb.
- b. *Assilina*, D'Orb.
- Amphistegina*, D'Orb.
- Heterostegina*, D'Orb.

\* The systematic place of these two forms is not well understood.

Cyclocypeus, Carpenter.  
Orbitoides, D'Orb.  
Fusulina, Fischer.  
Archæosphærina (?), Dawson.  
Archædiscus, Brady.  
Eozoon, Dawson. Fixed.

*(The systematic place of the following is not yet determined.)*

Caunopora, Phillips.  
Cœnostroma, Winchell.  
Sparsispongia, D'Orb.  
Stromatocerium, Hall.  
Stromatopora, Goldfuss.

---

PROGRESS OF MICROSCOPICAL SCIENCE.

---

*Vegetable Parasites in Corals.*—In the 'Proceedings of the Royal Society' (No. 164), in a long and valuable paper by Mr. H. N. Moseley on corals found during the 'Challenger' expedition, there appears the following note on the question of parasitism:—The corallum of both *Millepora* and *Pocillopora* is permeated by fine ramified canals, formed by parasitic vegetable organisms of the same nature as those described by Dr. Carpenter and Professor Kölliker as occurring in the shells of mollusks, &c. The organisms were found in abundant fructification; they are green, but otherwise appear to be fungi, as are the parasites of shells, &c. Similar parasites are to be found in various coralla from widely distant parts of the world.

*Form and Size of the Batrachian Blood-corpuscles.*—Professor Guliver, F.R.S., in his recent paper before the Zoological Society makes the following observations on the blood-globules of the Batrachia:—On each broad surface they are generally flat or somewhat vaulted; and their outline is regularly a well-defined oval figure, mixed occasionally with a few of a suboval or even circular shape, as indeed is the case among all regularly elliptical blood-disks, though this is rarer in Birds than in the lower classes and in the Camels. In Batrachians, the short diameter of the corpuscle being taken as 1, its long diameter would vary commonly between  $1\frac{1}{2}$  and  $1\frac{3}{4}$ . The thickness of the corpuscle is about one-third of its short diameter; and the nucleus may be either subrotund, or more commonly liker in shape to the envelope. The largest red blood-corpuscles of Vertebrates occur in the tailed Batrachians, of which *Amphiuma*, a caudocibranchiate species, has the largest of all, so that these are visible to the naked eye, and the perennibranchiate *Proteus* the next in size; and in *Sieboldia*, which has deciduous gills, the corpuscles are larger than in *Siredon*, which has permanent gills. In *Amphiuma* and *Proteus* the corpuscles are at least thrice as large as in some Frogs and Toads—an amount of difference of which there is no example either in the class of Birds or Reptiles, though it is exceeded among Apyrenæmata. The corpuscles in the anurous Batrachians are not always bigger than, and sometimes not so long as, in a few Reptiles and in some Sharks and Rays. The size of the corpuscles in Batrachians may differ in the same individual at different seasons. A few more observations on the corpuscles in this class are given in the 'Proceedings of the Zoological Society,' February 4, 1873.

---

## NOTES AND MEMORANDA.

**Examining the Blood-globules.**—Our readers will remember that some time ago there was an important discussion in these pages between Dr. Woodward and Dr. Richardson relative to the possibility of distinguishing the blood-globules of man from those of other mammalia with sufficient accuracy to determine points in medical jurisprudence. Now Dr. Richardson sends us a micro-photograph on which the blood of man and the pig are represented beside each other, and asks us whether they are not quite distinct. We answer, in the present instance they are perfectly distinct not only in size but in form, but we question whether this is always the case. However, the specimen is of interest.

**An Improved Form of Cox's Turn-table.**—We learn from the 'American Naturalist' for December 1875, that Miller Bros. of New York have made an improved form of this excellent contrivance, which is marked by its handsome iron stand and its careful adjustment of the centering movements. "If," says the 'A. N.,' "the real convenience of this table were known, its use would soon become general."

## CORRESPONDENCE.

## HERR HASERT'S OBJECTIVES: A REPLY TO F.R.M.S.

*To the Editor of the 'Monthly Microscopical Journal.'*

EISENACH, January 9, 1876.

DEAR SIR,—Fair play, if you please. Having been rather wantonly attacked by some man in your Journal, I hope you will give my reply a place in your columns. The report given by Mr. Hickie is certainly a statement of facts, after careful investigation, while the abuse of the Fellow R.M.S. seems to have no other foundation but ill-will. How much credit Dr. Dippel deserves, the following will show to all who interest themselves for truth. In two letters of Dr. Dippel, in my possession, dated 1861, 4/5 and 7/7, he says, "your objectives resolve in direct light from a north window, No. III. the XII., and No. II. the XX. group of Nobert's scale most distinctly;" in the second letter he says, "used with the achromatic condenser, both systems give very sharply defined images excellently suited for the most subtle anatomical investigations."

How much Dr. Dippel has since perfected himself in disregarding facts, I do not know, not having seen his edition since 1872; but in his first edition you will find sufficient contradictions regarding my lenses, if you will compare pages 119 with 143 and 169, where he gives my lenses in one place the highest resolving powers for diatoms,



in the other puts them down again. His love of truth and fair dealing is shown by the following observations:

Having advertised my objectives not needing correction, in the year 1864 I had a microscope exhibited at our meeting of "Naturforscher und Aerzte," in Giessen, giving everyone an opportunity to convince himself of the fact—the object-glass was  $\frac{1}{8}$ th. After the lovers of truth had convinced themselves of the correctness of my statement, in comes Dr. Dippel, bringing along with him an object, covered with a piece of looking-glass plate of at least three-quarters of a millim. in thickness, through which he knew well enough no  $\frac{1}{8}$ th in the world could reach, requesting me to put it under the microscope, to try how it would work with various thickness of covering glasses. When I told him that such covers could not be used under any lens of high power, he went away declining to make any trial of the lens, and then he threw out his innuendoes without any positive statements. Whether my lenses are capable of doing service, Dr. Schumann has shown. And in spite of the tyro-like brasswork, nearly all our first-class microscopists have either such bad microscopes or object-glasses of my construction, which are not made to look at, but to look through. Hoping you will help to right a much-wronged man,

I am most truly yours,

B. HASERT.

[We have pleasure in inserting Herr Hasert's letter. We have not altered his modes of expression, through a desire to maintain the exact character of his remarks.—Ed. 'M. M. J.']

#### THE NEW POWELL AND LEALAND $\frac{1}{8}$ TH.

To the Editor of the 'Monthly Microscopical Journal.'

BRISTOL SCHOOL OF CHEMISTRY, December 31, 1875.

SIR,—In communicating the following notes, I must premise that I have no wish to advocate any particular interest, nor yet to take part in the hot controversy which I regret to see raging round the peaceful instrument which has often given me peace. My aim is solely to endeavour to aid working microscopists by the results of my own experience.

In your June issue, Mr. Slack published some remarks on the "New-formula"  $\frac{1}{8}$ th of Messrs. Powell and Lealand which were very discouraging to those hoping to employ it for general work. Whilst fully admitting its exquisite resolving power on diatom tests, he stated that its working distance was extremely small and its penetration very limited, while it was difficult to use inasmuch as it gave a rapid, almost violent transition from perfect performance to bad performance, or even no performance at all. This report was disheartening, coming from such a well-known microscopist; but however it might have applied to the particular glass examined by Mr. Slack (which I am given to understand was one of the earliest dry ones), it is so singularly inapplicable to my more recent "im-

mersion," that it reads like a precise inversion of the real facts. I will not enter at present on the superb defining and resolving power of this glass (which remains clear and crisp under E ocular), but confine myself to the question of penetration and facility of working. [www.libtool.com.cn](http://www.libtool.com.cn)

Having lately, through the kindness of Mr. Curties, had a selection for examination of Zeiss'  $\frac{1}{3}$ ths and  $\frac{1}{4}$ ths, I took the opportunity to make an exhaustive comparison of the relative penetration of these low-angled glasses (only  $105^\circ$ ) against the Powell and Lealand  $\frac{1}{3}$ th, fully expecting to find the latter surpassed in this respect. I employed every kind of object which an  $\frac{1}{3}$ th could focus. I first took the coarser and more uneven diatoms; then spores, pollens, blood-disks, and the like; followed by the finer sections of vegetal and animal tissues, down to uncovered sections of rock containing crystals or arborescences in different planes. In every case, even these last extreme ones, the new  $\frac{1}{3}$ th gave at least as fine a general or perspective "picture," while the definition was of course far sharper. Hence I feel confident that every class of workers, histologists as well as diatomists, may derive the full benefit of this improvement in the objective, which seems to me the most important advance since the days of Andrew Ross. It is true that the working distance of this glass is small for an "immersion," being about the same as ordinary dry  $\frac{1}{3}$ ths of large angle.

I may add that some time ago Messrs. Powell and Lealand made me a  $\frac{1}{2}$ -inch of  $40^\circ$  for binocular use, which I find invaluable from its penetration and beauty of definition; also a fine 1-inch of  $20^\circ$ . I name this because these glasses are not in their published list, and I should have availed myself of them long before had I known they were procurable.

Having referred to the Zeiss lenses, I ought in justice to add that I find them (the  $\frac{1}{4}$ th more especially) well worthy the attention of all who may not require the highest attainable perfection. The corrections are well made, and the field flat, with plenty of light. The magnifying power of the Zeiss  $\frac{1}{3}$ th and Powell and Lealand immersion  $\frac{1}{3}$ th is the same, and measured at 10 inches with camera lucida on Ross's B ocular is  $\times 640$ ; that of the Zeiss  $\frac{1}{4}$ th,  $\times 875$ ; the adjusting collar being set half-way in the "run" in each case.

As a chemist, I would emphatically urge all who use immersion glasses to employ distilled water with them. Mere exposure to air, especially when aided by gentle warmth, causes ordinary waters to deposit an insoluble film of carbonate of lime, and when evaporation takes place during prolonged work, sulphate of lime may follow suit, and this cannot be dissolved off even by acid. It is obvious that any such coating on the front lens must sensibly impair its efficiency.

I am yours obediently,

FREDERICK W. GRIFFIN, Ph.D.

---

MR. WENHAM'S DEMONSTRATIONS ON THE IMMERSION APERTURE  
QUESTION.

To the Editor of the 'Monthly Microscopical Journal.'

224, REGENT STREET, LONDON, January 12, 1876.

SIR,—When Mr. Wenham asserts that the angular aperture of the image-pencil is the same whether the lens be used dry or with immersion, he seems to be unaware that this is equivalent to asserting that the aperture is the same whether used on uncovered or covered objects!

In his "simple demonstration," the refutation of his position is contained in the item,—That the lens must in both cases—e. g. wet or dry—be accurately focussed on the *surface* of the cube of glass. Now, the accurate focus cannot be obtained with a lens adjusted for immersion unless *immersion contact* be made; the lens when so adjusted will not give a sharp image of an uncovered object: so that when he speaks of adjusting a certain  $\frac{1}{3}$ th for immersion and focussing on the surface of the cube of glass *before the water is introduced*, he cannot be describing an actual experiment. It is no valid measurement of the aperture of the image-pencil unless the lens be so adjusted as to give true definition of the glass surface in each trial. There is no such thing, properly speaking, as aperture, unless the image of a point is seen as, approximately at least, a point; and that can only be ascertained either by trial or by going through a mass of laborious calculations.

Having satisfied myself that the position taken by Dr. Woodward and Professor Keith on the immersion aperture question can be substantiated both theoretically and experimentally, I gladly availed myself of Mr. Wenham's invitation to witness a practical demonstration directed by himself. By the terms of his letter, I was at liberty to have the test made with any lens in my possession. Accordingly, as he had already published a report of his measurement of the angular aperture of a  $\frac{1}{3}$ th immersion objective made by Tolles, of Boston, and as this measurement did not agree with what I had obtained with the same objective, I thought it would be more interesting to have the trial made with it. The owner of the lens, Mr. Frank Crisp, with great courtesy placed it in my hands for the purpose, together with the semi-cylinder of glass that was described by Mr. Wenham.

In the 'M. M. J.,' No. lxiii., p. 112, Mr. Wenham gave a description of the method he employed; and on p. 116 he wrote that with this identical lens and semi-cylinder, "the balsam aperture *with closed lenses* was only  $68^\circ$ , . . . and this angle of  $68^\circ$  was the same whether water was introduced or not between the plane surface of front lens and semi-cylinder, taking care to focus (?) in either case"! He mentions that "a minute stop of leaf metal was placed in the centre [of the plane surface of the semi-cylinder] so as to cut off extraneous rays." On the next page he says that he had "rather over than under estimated the aperture from using a stop too large; less than  $\frac{1}{3}$ th of an inch would have been more proper."

From this it will be seen he used a stop of at least  $\frac{1}{50}$ th of an inch diameter, and that with it he stated he measured the immersion aperture as  $68^\circ$ !

I need not recapitulate the details of the method employed by him in my presence. In every essential particular the conditions stated in his paper were observed; the result was that the immersion aperture measured not  $68^\circ$  only, but upwards of  $90^\circ$ !

And again, with the same slit and with another =  $\cdot 009$  inch (less than one-half of the one described by him), and with the lens set at its best adjustment and accurately focussed in each case on the surface of the semi-cylinder in water contact, the apertures shown by the bi-section of the field of the ocular, in rotating the microscope horizontally, were also beyond  $90^\circ$ !

I leave Mr. Wenham to explain the discrepancy between the result he published in March 1874 and the results here given. The facts are plain enough: we used the same  $\frac{1}{50}$ th immersion, the same semi-cylinder, a slit opening of the width he described, viz.  $\frac{1}{50}$ th of an inch; but instead of arriving at his former result of  $68^\circ$ , we measured the immersion aperture as beyond  $90^\circ$ . And as, in his paper, he suggested the measurement would be still more accurate with a narrower slit opening, we tried  $\cdot 009$  inch,—and again obtained beyond  $90^\circ$ .

Professor Keith has shown in the Journal for December last that the width of the slit opening cannot affect in any way the measurement of the immersion aperture. It should, however, be observed that the practical application of a very narrow slit on the plane surface of the semi-cylinder involves considerable attention; but the refinement of the method will only make the experimental proof more nearly coincide with theory.

In criticising the position assumed by Mr. Wenham on the immersion aperture question, I am compelled to take his utterances in the 'M. M. J.' as representing the views he holds. He has expressed himself unreservedly against the possibility of an object-glass refracting image-forming rays beyond what he terms the limit of  $82^\circ$  from balsam—making that appear to be the *natural limit*, or "full aperture."\* Professor Keith touched upon this point in his letter to the Journal, No. lxiii., p. 132, thus:

"All see that the limit  $82^\circ$  depends upon the difference of refractive power at a *plane surface*; that is, upon *two variables*; and, therefore, necessarily changes with a change in either of them. If balsam is substituted for air between the objective and the cover, the refracting surface is practically removed from the cover to the posterior surface of the front lens, from a *plane* to a *curve*, and the limit, which depends upon the *curvature*, changes with *that variable*."

Mr. Wenham's reasonings have all appeared to ignore this most important view of the question, by which it is shown that the "critical" angle for refraction into air imposes no *natural limit* when the rays do not go into air at all till they reach the second surface of the front lens, which, far from being parallel to the front, is deeply curved.

\* See 'M. M. J.' No. xxv., p. 117; xxvii., p. 118; lxiii., p. 119; lxxv., p. 48.

That the limiting angle at which rays could be admitted into balsam through a *flat* plate of glass imposes any *natural* limit to the angle up to which an object-glass could collect image-forming rays, supposing them to have got into the balsam, is absurd.

In the discussion on the immersion aperture question, the point insisted on by Dr. Woodward, Professor Keith, and Mr. Tolles, is, that, by means of the immersion principle, image-forming rays beyond the angle  $82^\circ$  from a balsam-mounted object—or from any object under equivalent conditions—can be transmitted into the optical image: the question then refers only to rays from balsam beyond the angle of  $82^\circ$ . Dr. Woodward's demonstrations, supported by Professor Keith's computation, were brought forward in illustration of the fact that by a properly devised objective such rays are transmissible. As Mr. Wenham rejects Professor Keith's diagram, he is bound to prove it erroneous, by a graphical method if he likes, *marking in the same data*. It will not do for him to reject the diagram on the ground that the data were furnished by Mr. Tolles to "suit the proposition;" for, since this discussion has been revived, M. Prazmowski, of the firm of Hartnack et Prazmowski, the well-known opticians of Paris and Potsdam, has submitted for my inspection a number of his computations referring to immersion lenses made any time during the last fourteen years, every one of which contains distinct tracing, by the trigonometrical method, of rays from the conjugate focus of greater angle than those transmissible by a dry objective. It is therefore evident that formulæ, involving the transmission of an angle of image-forming rays greater than corresponds to the maximum air-angle, have been known during this number of years.

Mr. Wenham's demonstrations seem to have been based on the assumption that his diagram in the 'M. M. J.,' No. xxv., p. 23, explained the whole theory of the action of the immersion system. But the rays there figured are merely the rays corresponding to those transmitted by the dry combination,—which are not concerned in the matter disputed. And in his so-called demonstration in No. xlvii., p. 231 *et seq.*, the image-pencil belonging to the air-limit theory is the only one with which he deals,—he takes for granted that the flat plate limit of refraction from balsam or glass into air— $82^\circ$ —is the natural limit beyond which no object-glass can collect image-forming rays. Such an objective as the one to which he referred cannot be said to have an immersion aperture in the proper acceptation of the term; because, if its construction be such that its maximum aperture is expressed by the air-pencil of  $170^\circ$  and *no more*, when water is introduced between the objective front and the cover-glass, the lens will no longer render "the image of a point as, approximately at least, a point,"—it admits of no adjustment by which a true immersion focus can be obtained, consequently the immersion aperture cannot be determined. That demonstration does not really touch the "balsam aperture question."

As Mr. Wenham still insists\* that the angle  $82^\circ$  from balsam is the *natural limit*, or *full aperture*, "beyond which no object-glass can

\* 'M. M. J.,' No. lxxxv., p. 48.

collect image-forming rays," the *onus probandi* rests on him. It will not do to tell us he has repeatedly given simple demonstrations of the truth of his proposition. I have shown that he has been lax in testing his own demonstrations,—that with the very lens reported upon, an immersion aperture upwards of  $8^\circ$  beyond the *limit* he contends for has been measured by himself—with his own method—in my presence. His former measurement must therefore be rejected, and Dr. Woodward, Professor Keith, and Mr. Tolles may claim this practical demonstration in proof of their position.

I would request those who are interested in the subject to observe that in Mr. Wenham's published account of his measurements of the aperture of the  $\frac{1}{4}$ th lens by Tolles—to which I have above referred—several pages are devoted to an irrelevant and misleading report concerning the aperture of the lens when used dry. It being admitted that no image-forming aperture can be measured unless the lens be so adjusted as to give a true image of the glass surface of the cube or semi-cylinder, it is absolutely essential that means be taken to verify whether or not this has been done. What then is the value of his report on the air-aperture of this lens when it becomes known that at no point of adjustment will it give a true image of an uncovered object? The lens was designed for immersion; it will not focus on an uncovered object; when, therefore, he set the lens at "closed"—or maximum angle—by what process did he determine the focal distance to be  $\cdot 013$  inch, so as to enable him to state the air-aperture to be necessarily less than  $118^\circ$ ?

With such a front lens as that of Mr. Tolles, the aberration if used on an uncovered object is so enormous that there is really no such thing as an air-aperture; and by taking this or that point as the best focal distance, and this or that point as the best adjustment of the lens, Mr. Wenham might have made the air-aperture anything within  $180^\circ$ . Apart from the question of aberration, he might have measured the air-aperture to be any angle from about  $110^\circ$  to—say— $175^\circ$ .

It remains that I express my willingness to let the trial of the immersion aperture of this  $\frac{1}{4}$ th lens be repeated at the Society's rooms—*strictly according to the terms stated in Mr. Wenham's report*—on any evening that may be appointed by the President of the Society.

I am, Sir, your obedient servant,

JOHN MAYALL, jun.

#### COURTESY IN CORRESPONDENCE.

*To the Editor of the 'Monthly Microscopical Journal.'*

HARTLEY COURT, READING, January 14, 1876.

DEAR SIR,—I doubt whether the objects of the Royal charter granted to the Society (to which many esteem it an honour to belong) can be said to be furthered by the style of letters sometimes communicated to the Journal.

As for those letters recently published by Messrs. Hogg, Brooke, and Wenham, I hope and would fain believe that these gentlemen

will regret on further reflection that they ever wrote them. The time is passed when an honest search after scientific truth can be satisfied with mere school-room versions of science. And as I entertain no apprehension as to the establishment of the principles laid down in my paper, I merely at present remark that any inquiry after truth should be conducted with the courtesy befitting the members of a Royally chartered Society.

I am yours faithfully,

G. W. ROYSTON-PIGOTT.

---

MR. WENHAM'S EXPLANATION OF THE REFLEX ILLUMINATOR.

*To the Editor of the 'Monthly Microscopical Journal.'*

SIR,—In Mr. Wenham's explanatory letter on the Reflex Illuminator in the current (January) number of the Journal, the following passage occurs :

"All light being thrown on top surface of slide, at an internal angle beyond that of total reflexion, the field is quite dark with objectives of the largest aperture—not the most extreme rays of which can admit them."

Will Mr. Wenham kindly explain the meaning of the phrase I have placed in italics ?

Your obedient servant,

AKAKIA.

---

PROCEEDINGS OF SOCIETIES.

ROYAL MICROSCOPICAL SOCIETY.

KING'S COLLEGE, January 5, 1876.

Charles Brooke, Esq., F.R.S., Vice-President, in the chair.

The minutes of the preceding meeting were read and confirmed.

A list of donations to the Society was read by the Secretary, and the thanks of the meeting were voted to the donors.

The Secretary reminded the Fellows that the next ordinary meeting would be their anniversary, at which Officers and Council for the ensuing year would be elected; and the following list of gentlemen nominated by the Council was then read :

As *President*—H. C. Sorby, Esq., F.R.S., &c.

As *Vice-Presidents*—Dr. W. B. Carpenter, Charles Brooke, F.R.S., Hugh Powell, and Rev. W. H. Dallinger.

As *Treasurer*—J. W. Stephenson, Esq.

As *Secretaries*—Messrs. H. J. Slack and Charles Stewart.

As *Members of Council*—Dr. Braithwaite, F. Crisp, J. E. Ingpen, E. W. Jones, Dr. Henry Lawson, W. T. Loy, Dr. John Matthews,



Dr. Millar, J. R. Mummary, F. H. Ward, F. H. Wenham, C. F. White.

The Chairman requested the meeting to appoint two gentlemen as auditors of the Society's accounts; when Mr. W. A. Bevington was proposed by Mr. Curties, and seconded by Mr. Shadbolt; Mr. B. D. Jackson was proposed by Mr. Guimaraens, and seconded by Mr. McIntire.

The Chairman then submitted these nominations to the meeting, and the two gentlemen named were duly elected.

The Secretary said that it would be remembered that some time ago they received a present from Mr. Hanks, of California, consisting for the most part of specimens of the mineral and other products of that country. Since that time Mr. Loy had kindly mounted for the Society a number of those specimens, and had done so in a very beautiful manner, as might be seen by looking at the slides on the table. Amongst the slides might be mentioned those of gold, silver, various crystals, portions of fossil pine wood, a Podura, curious as being found upon the snow of the Sierra Nevada, and also a very beautiful polychroic substance, sesquioxide of chromium.

The thanks of the meeting were unanimously voted to Mr. Loy for having mounted the specimens in the manner described.

Mr. Tylor said, should any of the Fellows of the Society feel inclined to return the compliment, by sending out some objects to the Microscopical Society of San Francisco (of which Mr. Hanks was president) he should be very happy to take charge of them for the purpose.

Mr. Charles Stewart called attention to some slides of *Aulacodiscus Kittoni*, which had been presented to the Society by Mr. Curties, having been obtained from *matériel* collected during the late Congo expedition by Mr. Martin, of H.M.S. 'Spiteful.' On looking at them he found that many of the disk-like boxes were united in columns of two or three in number, and he should like to know if this was a merely accidental cohesion, like that which was seen in the case of the red corpuscles of the blood, or like thin disks of cork floating freely on water, or whether it was the result of division of the diatoms in the process of forming two boxes out of one, after the manner of *Biddulphia*. Mr. Stewart then drew the appearances he had described upon the black-board, and observed that it would be extremely interesting to know how this interlocking came about.

In the absence of any formal paper, Mr. Charles Stewart gave a highly interesting description of the life history of the sponges, showing their general structure, mode of growth and reproduction. He illustrated his remarks by numerous drawings upon the black-board, and concluded by explaining the probable method in which the glass rope of the *Hyalonema* was formed, and also by reference to the power of boring into hard substances possessed by some of the smaller members of the sponge tribe.

The Vice-President expressed the great pleasure with which he—and doubtless all present also—had listened to Mr. Stewart's remarks;

for his own part, he had not only been much interested, but had also derived a great deal of information.

The thanks of the meeting were unanimously voted to Mr. Stewart for his communication.

Mr. Hickie then exhibited to the meeting a series of photographs, and read letters from Dr. L. Rabenhorst and Herr Seibert on the subject of the striæ of *Frustulia Saxonica*, with a view to prove its complete distinction from *Navicula crassinervis*. (Mr. Hickie's communication will appear in our next number, having been "crushed out" with much other interesting matter.)

Dr. Lawson inquired if what Col. Woodward stated was correct, viz. that the transverse striæ had always a definite number, but that the longitudinal ones varied with alteration of focus.

Mr. Hickie said that Dr. Woodward's remark, though new, was not true; \* he could himself do exactly the same with another specimen perfectly well known to all, and if Dr. Lawson would call upon him he would show him exactly what Dr. Woodward had described.

Mr. Curties hoped that Mr. Hickie would succeed in throwing some light upon the subject as to the species of this object, and would be able to show them how *Rhomboides*, *Crassinervis*, and *Frustulia*, when viewed by a proper and suitable glass, could be distinguished beyond the possibility of a mistake of any kind.

Mr. Hickie said the photographs marked C, D, and E, looked exactly like *Crassinervis*, because in that the median line ran almost perfectly to the end. In *Saxonica* it was not so, it was also pinched in at the end, and the ratio of the diameter was greatly in excess in proportion to the length.

Mr. Shadbolt said that when Mr. Stewart was speaking about *Aulacodiscus* he was rather surprised to hear that he suggested the probability of these shells coming together in this way accidentally. Of course this might sometimes occur, but they could hardly expect it to do it so as to form a whole column. In examining *Arachnoidiscus* some years ago, he had not the shadow of a doubt that what he saw there of a similar kind was the result of division. (Drawing made on the black-board in further illustration.)

Mr. Stewart said he had intended to say that *Aulacodiscus* did really increase by division, but in the particular slide in question the fact of the columns being formed of different sized individuals led him to suppose that in these cases it might be the result of accidental agglomeration.

Mr. Mayall inquired what evidence there was that the objects photographed in Germany as described by Mr. Hickie were really *Frustulia Saxonica*. He had seen a great many similar objects, and had obtained the same appearances with  $\frac{1}{4}$ -inch or  $\frac{1}{8}$ -inch objectives, whereas Dr. Woodward's specimens were represented as seen by  $\frac{1}{12}$ -inch or  $\frac{1}{16}$ -inch. After looking at the photographs now exhibited, he thought they were of a coarse form of *Rhomboides*.

\* There can be no doubt that diffraction lines can be produced as Dr. Woodward states.—H. J. S.

Mr. Hickie thought that *Frustulia Saxonica* being found in Saxony must be better known to Saxon people than others. There really was no difference whatever between *Rhomboides* and *Saxonica*, but there was a very great difference between them and *Crassinervis*.

The meeting then separated until February 2, when the anniversary will be held.

Donations to the Library and Cabinet since December 1, 1875 :

	From
Nature. Weekly .. .. .	<i>The Editor.</i>
Athenæum. Weekly .. .. .	<i>Ditto.</i>
Society of Arts Journal .. .. .	<i>Society.</i>
The Microscope in Gynæcology. By A. Mead Edwards, M.D.	<i>Author.</i>
Popular Science Review. No. 58 .. .. .	<i>Editor.</i>
Transactions of the Linnean Society. Two parts .. .. .	<i>Society.</i>
Two Slides of <i>Aulacodiscus Kittoni</i> .. .. .	<i>Thomas Curties, Esq.</i>

The following gentlemen were elected Fellows of the Society :—

The Rev. Thomas Wesley Freckelton ; William Brindley, Esq. ; Charles William Hovenden, Esq.

WALTER W. REEVES,

*Assist.-Secretary.*

#### MEDICAL MICROSCOPICAL SOCIETY.

Dec. 17, 1875.—H. Power, Esq., Vice-President, in the chair.

Dr. Pritchard exhibited in action the new freezing machine for cutting microscopic sections, and which has already been described in the 'Lancet' for December 11, 1875. The principle upon which its action depends is that a block of copper cooled by immersion in ice and salt will retain its low temperature sufficiently long in water to enable sections to be cut from a small piece of any soft tissue placed upon it, and which by contact with it has become frozen and adherent to its surface. If first immersed in gum water the specimens solidified better.

In the discussion that followed, Mr. Ward suggested using a metal plug in the same way as Dr. Pritchard recommended, only dropping it into an ordinary microtome tube so as to obtain the additional advantage of a rest for the razor.

Mr. Groves thought that if the plug were hollowed so as to contain some ice and salt, it would remain cold much longer.

*Acarus in Diabetic Urine.*—Mr. Jabez Hogg showed a specimen of urine from a case of incipient diabetes which contained large quantities of the *Acarus domesticus*, as well as particles of indigo. Twenty-four hours after being voided he observed their presence, and up to the present time they were still alive and breeding (for they were seen in all stages of development) though six weeks had elapsed. The mycelium of the diabetic fungus had appeared and the indigo was increasing. It was possible that the animal fed on these two substances. He had only examined this one specimen, and had kept it in the bottle in which it had been sent to him, in the window all the time. He had no doubt it was the ordinary sugar acarus, and must have obtained access to the urine in the first instance by accident.

THE  
MONTHLY MICROSCOPICAL JOURNAL.

MARCH 1, 1876.

---

---

I.—THE PRESIDENT'S ADDRESS.

By H. C. SORBY, F.R.S., F.L.S., F.G.S., F.Z.S., &c.

(*Delivered before the ROYAL MICROSCOPICAL SOCIETY, February 2, 1876.*)

IN selecting a subject for my address, it appeared to me more desirable to direct attention to some special questions more or less intimately connected with branches of science which I have perhaps studied more than most of those who are familiar with the general applications of the microscope, rather than to pass in review the many interesting communications that have been made to us during the past year. These have been of that varying character which it is so desirable for our Society to have. Several have treated on new apparatus, and on the improvement or improved use of older contrivances of different kinds, or on the methods to be employed in the examination of the microscope, and in testing its performances. We have also had a number of excellent papers on single objects of interest, both animal and vegetable, as well as others treating on more general and wider biological subjects. On the whole, I think we have good reason to congratulate ourselves on what has been brought before us. Time would not allow me to mention and discuss the various memoirs in detail, and also to lay before you a special subject which appears to me well worthy of consideration, viz. the relation between the limit of the powers of the microscope and the ultimate molecules of organic and inorganic matter. At all events, I think that this subject may lay claim to sufficient novelty; since, so far as I have been able to learn from consulting the index of the various volumes, no one during the last fifteen years has treated on this question; and until within the last few years none of the requisite data were known. Even now many of them are so imperfect, that nothing more can be done than to make the most probable assumptions. This necessarily imparts more or less of a speculative character to some parts of the subject, but I hope this will be pardoned on such an occasion as the present. It appears to me that in his annual address, the President of a society cannot do better than endeavour to point out the bearing of what is already known on some great question; and if in doing this the necessity of more accurate knowledge is made apparent, there is more hope for the future. The importance of particular classes of facts may not, and very

often is not, apparent until their connection with some special question is fully appreciated. It will, I am sure, be a source of great satisfaction to me if what I shall say should lead to the more accurate study of some of the data necessary to change my suppositions into well-established conclusions, whether they agree with my own or not.

Though fully impressed with the imperfect state of our present knowledge of the ultimate constitution of organic matter, yet even now the facts are sufficiently definite to indicate, if not indeed to prove, the existence of as wide a world of structure beyond the limit of the power of the microscope, as what has been revealed to us by it is beyond the powers of the unassisted human eye. I think we may very fairly conclude that the ultimate structure, even of organic bodies, will for ever be invisible, and the only chance of obtaining some knowledge respecting it is by indirect methods of research. For my own part, I look forward with hope and confidence to a great increase in our knowledge of this question by the further study of the optical characters of both organic and inorganic substances, that is to say, by using light so that it may suffer changes easily appreciated by our organs of vision, though the ultimate molecules of the object examined may be so small in relation to the wave-length of light, that even light itself is *far too coarse a means* for transmitting to our eyes any distinct impression of actual form or magnitude. There are also other branches of physical science which serve to teach much in connection with this subject, but as yet even these fail to satisfy all the requirements of the case. The whole question is beset with the greatest difficulties, and even when we make use of the best data hitherto obtained, we see at once how very imperfect they are. One reason perhaps is that the importance of the subject has not been sufficiently appreciated, and comparatively little has been done to develop it even as far as is possible. I think I may safely say that what has been done relates exclusively to the elementary substances, or to the most simple chemical compounds. Nothing, or next to nothing, is known respecting the size and structure of the molecules of the very complex substances met with in animals and plants, and when we come to consider what may be their ultimate nature when forming a part of living tissue, we are immediately brought face to face with questions which have probably never once attracted the attention of physicists; since as a rule their studies do not lead them into the consideration of biological problems.

I propose to discuss my subject under three heads:

1. The limit of the powers of the microscope.
2. The size of the ultimate molecules of organic and inorganic matter.
3. Conclusions to be drawn from the general facts.

1. *Limit of the Powers of the Microscope.*

In treating this question I have no intention to enter into the consideration of the best form or arrangement of lenses to ensure the least possible amount of spherical or chromatic aberration, nor how far for the purposes of research it is desirable to make a compromise between those practical difficulties which cannot all be entirely overcome at one time. I shall assume that the instrument itself is theoretically perfect, and consider only the limit of vision due to the organization of our own eyes, and still more that due to the physical characters of light.

The visibility of a very minute object necessarily depends on a number of different circumstances. If examined by transmitted light it must either absorb sufficient to make the contrast between it and the general field great enough for the eye to recognize, or it must be of such a shape and of such a refractive power in relation to the surrounding medium as to bend the light which passes near the edges out of the general direction of the transmitted beam, so as to give rise to a sufficiently dark and definite outline. In my treatment of the question, I however assume that the character of the object examined is in every respect such as would enable us to see it, if it were not for difficulties of another kind.

The purely physiological part of the question has not attracted much of my attention, since I did not believe that the ultimate limit of distinct vision would be found to depend on the constitution of the eye. It may, however, be well to give a short account of some experiments made by Dr. Royston-Pigott with the view to determine the physiological limit, which he has kindly communicated to me, and permitted me to employ, in order to show that the above-named conclusion is justified by experiment. He found that the smallest visual angle that he could ever distinctly appreciate was a hole  $1\frac{1}{4}$  inch in diameter at a distance of 1100 yards, which corresponds to about 6" of arc. This visual arc in a microscope magnifying 1000 linear would correspond to about the three-millionth part of an inch. Some persons, however, affirm that the smallest visible angle is 1', or ten times the above, which would correspond to  $\frac{1}{300000}$  of an inch. If such be the case, the eye could distinguish with a high magnifying power a much smaller interval than the physical properties of light will permit.

Taking into consideration merely the swelling out of a minute point of light due to diffraction, Dr. Royston-Pigott thinks that the limit of visibility must be from  $\frac{1}{130000}$  to  $\frac{1}{300000}$  of an inch. This, however, is not what appears to be the most important character of light in limiting the power of the microscope for separating lines so near together that they may be obscured or their number falsified by interference fringes.

This subject has been treated of in a very complete and satisfactory manner by Helmholtz,\* whose authority on such a question few of us would venture to dispute. In his essay he maintains that the size of the smallest objects visible does not depend simply on their size, but very much on the susceptibility of the eye for faint differences in the intensity of light. For this reason the ultimate defining power of the microscope cannot be so well determined by the examination of single bright points or lines on a dark ground, or of single dark points or lines on a white ground, as by the use of fine gratings, which have alternate bright and dark stripes, as on Nobert's test-plate, and on the frustules of Diatomaceæ and the scales of insects. He contends that in the case of such objects the smallest distance that can be accurately defined depends upon the interference of the light passing, as it were, through the centres of the bright spaces, and that when this interference is of such a character that bright fringes are produced at the same intervals as the dark lines, and are superimposed on them, the lines can be no longer seen, and the normal limit of perfect definition has been reached. He, however, points out that by a favourable overlapping the dark portions of the fringes may occasionally so coincide with the true lines as to make it possible to see still smaller intervals, but that a certain and unequivocal perception of such lines would scarcely be possible. He then proceeds to show that this limit of true and distinct vision depends upon the angle of divergence of the light entering the object-glass of the microscope, and on the wave-length of the light, according to the following relations :

- $d$  = the distance between the lines ;  
 $\alpha$  = the angle of divergence ;  
 $\lambda$  = the length of the wave of the light ;

then we have

$$d = \frac{\lambda}{2 \sin. \alpha}.$$

This angle of divergence is equivalent to one-half of the true angle of aperture, when illuminated by an equally large pencil of light ; but at the same time one cannot but think that in actual practice the results must be made somewhat more complex, owing to the presence of light having a less angle of divergence than the extreme. All the calculations are also made for true focal adjustment and correction of the lenses, and if these be not actually correct the combined effect of all the disturbing causes must necessarily give rise to many appearances not easily explained. Of course these remarks do not in any way apply to minute bright points.

The formula given by Helmholtz is entirely different from that

\* Poggendorff's 'Annalen,' Jubelband, 1874, p. 573.



adopted by Nobert, which is based on the supposition that the rays of light used for illumination are parallel, and entirely ignores the question of aperture. As Dr. Woodward has shown,\* the limit given by Nobert's formula is not at all borne out by observation, since lines can be distinguished at a much smaller interval than indicated by the manifestly incomplete theory. This remark will not apply in the case of Helmholtz's formula, which appears to be fully substantiated by observation.

Adopting, then, the most simple applications of Helmholtz's formula as an illustration of the general question, I have calculated what is the limit for the red and blue ends of the spectrum, and for the mean rays, according to the following wave-lengths, given for simplicity in fractions of an inch :

Red end	..	..	..	..	..	..	..	$\frac{37}{1000}$
Mean rays	..	..	..	..	..	..	..	$\frac{45}{1100}$
Blue end	..	..	..	..	..	..	..	$\frac{50}{1400}$

I have also calculated the limit for a few widely different angles of divergence, giving double these in order to make the comparison more simple with the angle of aperture as usually expressed, assuming of course that the angle of divergence of the light from the condenser is equally great.

60°, which gives the wave-length as the limit.

97°, which gives three-fourths of the wave-length as limit.

120°.

150°.

180°, or an angle so great that its sine is near unity, whether practicably possible or not. This gives for the limit half the wave-length of the light.

The results are expressed in the following table, in which I give the nearest round numbers :

		60°	97°	120°	150°	180°
Red end	.. ..	37000	45000	54000	71000	72000
Mean rays	.. ..	45000	55000	60000	65000	65000
Blue end	.. ..	50000	55000	70000	71000	72000

All these limits are calculated for dry lenses. For immersion lenses of equal aperture the limits would in all cases be about three-fourths of the various magnitudes here given. In order to see such minute intervals, of course a high magnifying power is necessary, but when the interval is less an increased power would magnify the defects and the object equally.

\* 'Monthly Microscopical Journal,' vol. ii., 1869, p. 289.

An examination of the table will clearly show the value of a large aperture in defining lines at very small intervals on flat objects like Diatomacæ, though in practice this advantage may be entirely counterbalanced by other disadvantages in the case of a different class of objects. The largest possible aperture would define lines at half the distance apart that could be defined with an aperture of only  $60^\circ$ . It follows from the law of the sine that there would be a rapid increase in defining power on increasing the aperture when small, but when large a similar increase would have no such corresponding advantage. Mr. Jabez Hogg informs me that by a comparison of different object-glasses he has been led to conclude that the defining power varies as the chord of the aperture, which of course is in absolute agreement with this theory of Helmholtz. It is the same, only expressed in different words. Of course the defining power of different object-glasses depends on several other circumstances; but since we find that many of the facts may be explained by the action of the interference fringes, depending on the essential characters of light itself, no matter how perfect the manufacture of the instrument or the capabilities of the eye, it appears to me that they deserve far more consideration than has been given to them. Their influence has been entirely overlooked by many who have treated on this question. At all events, since they are altogether independent of the mechanical construction of the instrument, it appears to me that we cannot do better than adopt these principles in forming some conclusion as to the size of the smallest object that could be distinctly seen with a *theoretically perfect microscope*. Looked at from this point of view alone, with a *dry lens* this could not be less than  $\frac{1}{80000}$  of an inch. Even when  $\frac{1}{74000}$  the fringes due to the extreme red rays would begin to produce partial obscurity, and at  $\frac{1}{72000}$  the brightest part of the spectrum would make the obscurity more or less complete. If it were possible to make use of the blue end alone, lines of  $\frac{1}{110000}$  could still be seen, since their shorter waves would not produce obscurity until the size was reduced to  $\frac{1}{120000}$  of an inch. The size of the smallest bright point that could be seen depends on entirely different considerations, and might be considerably less, as far as the physical constitution of light is concerned.

The question now arises, Are these general conclusions borne out by actual observation? As far as I am able to judge from such evidence as I have been able to collect, they are very strongly confirmed, if not actually established. Thus, according to Helmholtz, Dippel\* found that the limit of the true resolution of Nobert's lines was about  $\frac{1}{80000}$  of an inch, which is just within the limit for the mean rays, with a very wide aperture. By theory this limit might be considerably exceeded by the use of blue light; and, since the

\* 'Das Mikroskop und seine Anwendung,' 1867.

rays at the blue end of the spectrum are those which are active in photographing, it might be possible to obtain a good photograph of lines not distinctly visible when mixed light is employed. This, Helmholtz thinks, explains why Stinde was able to photograph lines on *Surirella gemma* which were  $\frac{1}{100000}$  of an inch apart, and therefore considerably within the possible limit. Helmholtz does not appear to have seen the papers on Nobert's bands by Stodder\* and by Dr. Woodward,† which contain many facts of great interest in connection with this subject.

In reading these papers it is easy to perceive that the true resolution of one of Nobert's bands, which according to Dr. Woodward contains lines at a distance of about  $\frac{1}{117000}$  of an English inch, is a matter of such extreme difficulty, even with the best object-glasses, that, if the exact nature of the object and the number of lines were not known, it would be almost impossible to decide how many lines there were to an inch. The lines due to interference are often as distinct as the true lines on the glass, and Dr. Woodward believes that such spurious lines, and not the actual, were seen and counted by Stodder; since the number was not correct. The black lines due to interference do occur beyond the limit of the true, and at closely the same intervals as the real, as should be the case according to Helmholtz's theory. Now it is quite manifest that the distinctness of definition depends on how these spurious bands occur in relation to the true. If they exactly overlap, the definition would be good, and the lines distinct; but, if they occurred at the half intervals, the dark part of one series occurring at the bright part of the other would more or less completely obliterate both. It appears to me very probable that these facts will in great measure explain the phenomena seen when the light is thrown on the lines at a varying angle, since in one position the lines cannot be defined, on increasing the obliquity false lines are visible, and with still more oblique light the true may be seen. An alteration in the angle of aperture of the condenser would also alter the distance of the diffraction bands; and therefore, taking all these facts into consideration, we may easily explain why, as Helmholtz says, it is possible under such favourable conditions, with lines at equal intervals, to distinguish them when closer together than what is the normal limit of the distance at which they can be seen without any special difficulty, even when not at equal intervals, that is to say, when the intervals are greater than that of the bands due to diffraction. Even then, however, they do occur in varying numbers and position between the true lines, as may be seen in photographed diffraction gratings.

\* 'Quart. Journ. of Micros. Science,' 1868, vol. viii., p. 133.

† Ibid., p. 225; 'Monthly Microscopical Journal,' 1871, vol. vi., p. 26; and 1872, vol. viii., p. 227.

Still, even the above-named Nobert's band is quite within the limits of what might be resolved by the use of blue light, and thus there is no difficulty in understanding how it might be photographed as done by Dr. Woodward.

Similar principles would of course apply in the case of the very close and uniform markings on the frustules of Diatomaceæ. Dr. Woodward's paper and admirable photographs of *Frustulia Saxonica*, brought before our Society at our meeting last November,\* fully bear out all Helmholtz's conclusions, and show the difficulty of distinguishing true structure from interference fringes when the intervals between the real markings are of the same order of magnitude as half the length of the waves of light. This effect is of course altogether independent of the quality of the lenses. It depends on the physical constitution of light itself, and would only be the more perfectly seen with more perfect object-glasses.

There is also another fact mentioned by Dr. Woodward which merits attention.† He says that for resolving very close lines or linear markings it is a decided advantage to have the lenses somewhat under-corrected for colour. As he suggests, this may be partly due to the possibility of making such lenses more correct for spherical aberration, but at the same time it appears to me quite possible that it may also to some extent be due to the fact that with such a correction it is possible so to have the lines in focus for the blue rays as to take advantage of their shorter wave-length, whilst the interference fringes due to the longer waves are sufficiently modified by being out of focus as to obscure the vision less than they otherwise would.

Taking then all these facts into consideration, it appears to me extremely probable that for object-glasses not made on the immersion principle the limit of perfectly satisfactory definition of lines not exactly the same distance apart must be somewhere about  $\frac{1}{80000}$  of an inch. With a dry lens having an aperture of  $140^\circ$ , or an immersion of  $100^\circ$ , both illuminated by a condenser of equal angle, only the extreme red rays would then serve to produce a very slight indistinctness. Under very favourable circumstances by varying the angle of divergence of the light passing from the condenser, or by throwing it more from one side than from the opposite, it would be possible to make the dark interference fringes so coincide with dark structural lines that a considerably smaller interval might be distinguished. This, however, would be extremely difficult if not impossible, if the lines were at unequal intervals, since any adjustment of the illumination that gave interference fringes at the proper interval and situation for one part of

\* 'Monthly Microscopical Journal,' 1875, vol. xiv., p. 274.

† 'Quart. Journ. of Micros. Science,' viii., p. 229.

the object would give them at such an interval and situation as would obscure the structural lines in another part, and by no single adjustment could the whole be seen correctly, but in all cases true and spurious lines would be mixed up together. The only chance of arriving at a true knowledge of the real structure would be by a careful induction from the facts observed when the illumination is made to vary; and even when a satisfactory conclusion could thus be drawn it would only be by acting on the principle that the limits of simple and distinct visibility had been passed, when light has to be treated as an agent scarcely fitted for the requirements of the case.

When we come to the examination of single detached particles the conditions are materially changed, but if the bright part of the interference fringes fall on the dark boundary line of a transparent particle or the bright part of a fringe on the centre of an opaque particle, it could not be distinctly seen though its presence might be recognized.

The limit of  $\frac{1}{80000}$  of an inch deduced on Helmholtz's principle from the physical characters of light agrees admirably with the estimate formed independently by various great authorities on the microscope. The mean of the estimate thus formed by Quekett, Ross, De la Rue, and Carpenter, as quoted by Stodder, is in fact exactly the same ( $\frac{1}{80000}$  of an inch), so that we cannot, I think, be far from the truth, if we take that as the base on which to build further conclusions. With an immersion object-glass of very large aperture it might be possible to define an interval of somewhat less than  $\frac{1}{100000}$  of an inch, but probably the above-named determinations were made with dry lenses. At all events, since the limit of visibility as determined by the use of the best modern microscopes agrees so completely with what appears to be the limit due to the physical constitution of light, we must, I think, conclude that our instruments do now enable us to see intervals so small in relation to the wave-length of light, that we can scarcely hope for improvement *as far as the mere visibility of minute objects is concerned*, whatever may remain to be done to improve their performances in other respects.

## 2. The Size of the Ultimate Atoms of Matter.

Having then come to the conclusion that the limit of distinct and unequivocal definition is somewhere about from  $\frac{1}{80000}$  to  $\frac{1}{100000}$  of an inch, it appears to me very desirable to consider what relation such a magnitude bears to the size of the ultimate atoms of organic and inorganic matter. From the very nature of the case the microscope altogether fails to throw any light on this question, and the only course as yet open to us is to draw the best

conclusions we can from the various properties of gases. This problem has been attacked by Stoney,\* Thomson,† and Clerk-Maxwell,‡ who, from various data, and by various methods of reasoning, have endeavoured to determine the number of ultimate atoms in a given volume of any permanent and perfect gas. In order to avoid inconveniently long rows of figures, I have reduced all their results to the number of ultimate atoms contained in a space of  $\sqrt[10]{100}$  of an inch cube, that is to say, in  $\sqrt[10000000000]{100}$  of a cubic inch, at  $0^{\circ}$  C. and a pressure of one atmosphere. These numbers are as follows :

Stoney .. .. .	1,901,000,000,000
Thomson .. .. .	98,320,000,000,000
Clerk-Maxwell .. .. .	311,000,000,000
Mean .. .. .	50,260,000,000,000

As will be seen, there is a very great discrepancy between the numbers given by Thomson and Clerk-Maxwell. This is in part due to the fact that Thomson gives the greatest probable number, whilst Clerk-Maxwell has endeavoured to express the true number indicated by the phenomena of inter-diffusion of gases. The determinations do to a great extent depend on the measurements of length, and any differences are of course greatly increased when the number of atoms in a given volume is calculated, since that varies as the cube of the linear dimensions. Extracting the cube root of each of the above numbers, we obtain the number of atoms that would lie end to end in the space of  $\sqrt[10]{100}$  of an inch in length. These are as follows :

Stoney .. .. .	12,390
Thomson .. .. .	46,160
Clerk-Maxwell .. .. .	6,770
Mean .. .. .	21,770

The cube of this mean is about 10,317,000,000,000, and, taking into consideration the various circumstances named above, it appears to me a far more probable approximation to the truth than the mean of the numbers in a cubic  $\sqrt[10]{100}$  of an inch as given by the authors. As will be apparent from the wide differences, even this mean result can be looked upon in no other light than a very rough approximation; but still, when we bear in mind that Thomson's result is given as a limit, it must be admitted that the numbers belong sufficiently to one general order of magnitude to justify our looking upon the mean as a tolerably satisfactory ground on which to form some provisional conclusions.

\* 'Philosophical Magazine,' 1868, vol. xxxvi., p. 132.

† 'Nature,' March 31, 1870, vol. i., p. 551.

‡ *Ibid.*, August 11, 1873, vol. viii., p. 298.

Now, if the gas containing the above-named number of atoms consisted of two volumes of hydrogen to one volume of oxygen, when combined to form vapour of water there would be a condensation of volume from three to two, and on condensing into a liquid a further contraction to  $\frac{1}{770}$  of the bulk of the vapour. Each molecule of water would however consist of three atoms of gas, and hence in order to determine the number of molecules of liquid water in  $\frac{1}{10000}$  of an inch cube, it is necessary to multiply the number in a gas by  $\frac{2}{3} \times 770 \times \frac{1}{3} = 385$ . This gives for the number of molecules of water in  $\frac{1}{10000}$  inch cube about 3,972,000,000,000,000. In this and all other cases I give round numbers, since any nearer approximation is impossible.

Though living organisms contain much water, yet far more complex substances enter into their composition. As an example of one of these, we may take albumen. According to Lieberkühn its composition is expressed by the formula  $C_{72}H_{112}N_{15}SO_{22}$ . It therefore contains seventy-one times as many ultimate atoms as water, and its atomic weight is about eighty-two times that of water. In the condition of horn I find that its specific gravity is about 1.31. Calculating from these data, I conclude that when the various constituents combine they contract to  $\frac{1}{9}$  of the total volume, and not as water to  $\frac{2}{3}$ ; and that the volume of a single molecule of albumen is about 55.6 that of a molecule of liquid water. If their form be similar, their diameter must therefore be 3.82 times that of a molecule of water. This would lead us to conclude that in a cube of  $\frac{1}{10000}$  of an inch of horn there are about 71,000,000,000,000 molecules of albumen.

According then to these principles there would be in the length of  $\frac{1}{10000}$  of an inch about 2000 molecules of water, or 520 of albumen, and hence, in order to see the ultimate constitution of organic bodies, it would be necessary to use a magnifying power of from 500 to 2000 times greater than those we now possess. These, however, for the reasons already given, would be of no use unless the waves of light were some  $\frac{1}{10000}$  part of the length they are, and our eyes and instruments correspondingly perfect. It will thus be seen that, even with our highest and best powers, we are about as far from seeing the ultimate constitution of organic matter as the naked eye is from seeing the smallest objects which they now reveal to us. Nor does there appear to be much hope that we ever shall see the ultimate constituents, since light itself is manifestly of too coarse a nature, even if it were possible to still further develop our optical resources. As matters now stand we are about as far from a knowledge of the ultimate structure of organic bodies as we should be of the contents of a newspaper seen with the naked eye at a distance of a third of a mile, under which circumstances the letters of various sizes would correspond to the smaller and



larger ultimate molecules. This being the case, we may feel persuaded that particles of organic matter, like the spores of many living organisms scarcely visible with the highest magnifying powers, and, if seen, quite undistinguishable from one another, might yet differ in an almost infinite number of structural characters, just as any number of different newspapers in various languages or with varying contents would look alike at the distance of a third of a mile.

### 3. *General Conclusions to be deduced from the above Facts.*

When we come to the application of these principles to the study of living matter, we are immediately led to feel how very little we know respecting some of the most important questions that could occupy our attention—questions which certainly never presented themselves to me, until I looked upon them from this point of view, and which perhaps have not occurred to anyone before. As illustrations of the subject now under consideration, I do not think I can select better than the facts bearing on the size and character of minute germs, and on Darwin's theory of ultimate organized gemmules, as described in Part ii. chapter xxvii. of his work on the variation of animals and plants under domestication. So far as I have been able to learn, he has nowhere given any opinion as to the probable *size* of such gemmules, nor discussed the probability of some of his speculations when examined from a *numerical* point of view, and in connection with the probable size of the *ultimate molecules* of organized matter. I therefore propose to do so; since, though not actually a microscopical question, it is most intimately connected with our studies, and as microscopists I think we have a good claim to investigate objects that are just beyond our magnifying powers.

For the sake of simplicity I will take into consideration only the albuminous constituents of animals, using the term albumen in a sort of generic sense, to include many compounds, which differ in many particulars, and yet have many in common. With slight modifications the same principles would apply in the case of other substances. Whatever be the special variety of this constituent, it is so associated with water in living tissues that in most, if not in all, cases they would cease to live if thoroughly dried. This is exemplified by the case of hair and horn, which must contain much water at the growing end, but are dead where hard and dry. In living tissues much of the water is no doubt present simply as a liquid mechanically mixed with the living particles, but it appears to me that we ought to look upon some portion as being in a state of *molecular combination*. So little attention has been directed to this kind of weak affinity, that its very existence is almost or quite

ignored in many large and important chemical works, and yet probably many of the phenomena of life are manifested only by such compounds. Very much light is thrown on this question by the study of the spectra and other optical characters of coloured substances. These clearly prove that when dissolved in any liquid the optical properties of the solution depend in part on the nature of the solvent, and are by no means the same as they would be if minute particles of the solid substance were diffused in the liquid. These facts cannot, I think, be explained unless we conclude that the solvent is to some extent in the state of molecular combination with the substance dissolved. This molecular affinity is also in some cases manifested by a swelling up of a solid substance when placed in some liquids, even when perfect solution occurs to a very limited extent. Such a condition appears to be very characteristic of the living tissues of animals, and makes it sufficiently probable that the ultimate living particles are molecular compounds with water, and not molecules of free dry albuminous substances.

Unfortunately, nothing definite is known respecting this question, and all that can now be done by way of illustration is to make some sort of a probable supposition. Taking everything into consideration, it appears to me that, as a reasonable example, we may assume that living albuminous tissue contains one-half of its volume of water mechanically mixed, and one-fourth its volume of free albumen united molecularly with an equal volume of water. On this supposition the number of molecules in  $\frac{1}{1000}$  of an inch cube would be about

Albumen .. .. .	18,000,000,000,000
Water in molecular combination .. ..	992,000,000,000,000
	1,010,000,000,000,000

Since, however, the form of minute living organisms more nearly approximates to spheres than to cubes, it will be more convenient to give the numbers in a sphere of  $\frac{1}{1000}$  of an inch in diameter. For this there would be about as follows :

Albumen .. .. .	10,000,000,000,000
Water in molecular combination .. ..	520,000,000,000,000
	530,000,000,000,000

In the present state of our knowledge it is perhaps impossible to say whether or not the essential characters of living particles are due to the structural arrangement of the molecules of this combined water as well as of those of the albumen, and whether or not in considering the possible variations in structure the total number of molecules should be taken into account. The very small relative amount of dry matter in some living animals does, however, make

it very probable that molecularly combined water really plays a part in their structure; and on the whole we may, I think, base our provisional calculations on the total number of molecules given above.

[www.libtool.com.cn](http://www.libtool.com.cn)

*The Theory of Invisible Germs.*

The relation between the size of the smallest object that can be seen, and that of the ultimate molecules of living matter, is manifestly a question of great importance in connection with the theory of germs. If the ultimate molecules were much larger than they appear to be, there would be serious objections to the theory; but, as far as we can judge, they are sufficiently small to make it possible for an almost endless variety of germs to exist, each having a distinct structural character, and yet each so small that there is no probability of our ever being able to see them, even as indefinite points. Thus, according to the principles described above, a sphere of organized matter one-tenth of the diameter of the smallest particle that could be clearly defined with our highest powers, might contain a million molecules of albumen and molecularly combined water. Variations in number, chemical character, and arrangement, would in such a case admit of an almost boundless variety of structural characters. The final velocity with which such extremely minute particles would subside in air must be so slow that they could penetrate into almost every place to which the atmosphere has access.

*Darwin's Theory of Pangenesis.*

Darwin's theory of pangenesis is an attempt to give something like a reasonable explanation of the phenomena of inheritance, and is not necessarily connected with the question of the evolution of new species. A full account of the theory will be found in his work on the variation of animals. At p. 374 of vol. ii. he says that "he assumes that cells before their conversion into completely passive or formed material, throw off minute granules or atoms, which circulate freely throughout the system, and when supplied with proper nutriment multiply by self-division, subsequently becoming developed into cells like those from which they were derived. These granules for the sake of distinctness may be called cell-gemmules, or, as the cellular theory is not fully established, simply gemmules. They are supposed to be transmitted from the parents to their offspring, and are generally developed in the generation which immediately succeeds, but are often transmitted in a dormant state during many generations, and are then developed. Their development is supposed to depend on their union with other partially developed cells or gemmules which precede them in the regular course of growth.

Gemmules are supposed to be thrown off by every cell or unit, not only during the adult state, but during all the stages of development. He assumes that the gemmules in their dormant state have a mutual affinity for each other, leading to their aggregation into buds or into the sexual elements. These assumptions constitute the provisional hypothesis which he calls Pangenesis."

In order to form some opinion as to whether the ultimate molecules of organic matter are of such a size as to make this theory possible or probable, it is necessary to form some idea as to the number of such molecules that may be united to make one gemmule. It must be very considerable, or else it seems difficult to understand how they could vary enough to explain the inheritance of many characters. Perhaps, for the sake of argument, we may assume that on an average each contains something like a million. Varying numbers, chemical constitution, and arrangement, would in such a case allow of an almost infinite variety; but of course we are so profoundly ignorant of many necessary details that this number can be looked upon only as a rough illustration of the application of a general method of study. On this supposition one thousand such gemmules massed together would form a sphere just distinctly visible with our highest and best magnifying powers. If the gemmules were of much greater or of much less magnitude, it appears to me very probable that Darwin's theory would break down from two opposite causes, or would need very considerable modification, because, if much greater, their number would be too few to transmit sufficiently varied characters, and, if much less, they could scarcely contain enough of the ultimate atoms of matter to have a sufficiently varied individual character to transmit, since of the assumed million ultimate molecules only eighteen thousand would be of a true protoplasmic nature, the rest being of water in molecular combination.

Adopting, then, this size as a basis for calculation, it is easy to form some opinion as to the number of gemmules that might be present in spermatozoa or in ova, assuming them to be their sole or chief constituent. Thus, for example, if we take  $\frac{1}{100000}$  of an inch as the mean diameter of a single mammalian spermatozoon, it might contain two and a half millions of such gemmules. If these were lost, destroyed, or fully developed at the rate of one in each second, this number would be exhausted in about one month; but, since a number of spermatozoa appears to be necessary to produce perfect fertilization, it is quite easy to understand that the number of gemmules introduced into the ovum may be so great that the influence of the male parent may be very marked, even after having been, as regards particular characters, apparently dormant for many years.

Then, again, adopting  $\frac{1}{100000}$  of an inch as the mean diameter of

the germinal vesicle of a mammalian ovum, it might contain above five hundred millions of gemmules. If these were lost or fully developed at the rate of one in each second, this number would not be exhausted until after a period of seventeen years. There would thus be no difficulty in understanding why the characters of the female parent might remain during life, even though apparently dormant for many years. This is still more the case if we take into consideration the entire ovum, since calculating on the supposition of its being a sphere  $\frac{1}{16}$  of an inch in diameter it might contain so many gemmules that if one were lost or developed in each second they might not all be exhausted until after 5600 years.

These calculations are made on the supposition that the entire mass is composed of gemmules. Of this there is little probability; but still, even if a considerable portion of the ovum consists of completely formed material and of mere nutritive matter, it may yet contain a sufficient number of gemmules to explain all the facts contemplated by the theory of pangenesis. The presence of any considerable amount of such passive matter in the spermatozoa would certainly be a serious difficulty in the way of the theory, unless indeed a very considerable number are invariably concerned in producing fertilization.

When, however, we come to apply similar reasoning to the inheritance by the second or following generations of characters which have remained apparently dormant in one or more previous generations, it appears to me that the gemmule theory would fail, unless gemmules have the power of reproducing others more or less closely resembling themselves, and of collecting together more especially in the sexual elements. This will, I think, be apparent from the following considerations.

An animal weighing 8 stones would contain about 3000 cubic inches, and thus its entire volume would be about six millions of millions times that of the germinal vesicle of an ovum. Hence, if the number of gemmules in a vesicle as given above were present in the grown-up animal and equally distributed over the whole body, there would only be enough to allow one for each thousand ova, or only one for a much greater number of spermatozoa.

I have treated this question entirely in its *physical* aspect, and made no reference to any other class of facts. The conclusions to which I have been thus led agree remarkably well with those of Darwin, though drawn from entirely different data. As will be seen, the probable size of the ultimate molecules of living matter is sufficiently minute to make the gemmule theory possible when examined from a purely physical point of view. If there had been good evidence to prove that the ultimate atoms of matter are very much larger than indicated by the properties of gases, the

gemmae theory could scarcely have been maintained, since the possible number of gemmae that could have been present in the germinal vesicle or spermatozoa would not have been adequate to explain the various facts of inheritance.

*Conclusion.*

As I have pointed out in the course of my remarks, there is still unfortunately very much doubt respecting many most important questions connected with this subject, and therefore my conclusions can be looked upon only as a first attempt to apply a physical kind of argument to various biological speculations. Even if our present knowledge is inadequate to make this attempt satisfactory, I trust that what I have said will be sufficient to show the need of a more complete study of the various questions to which I have directed attention. I hope myself to study them much more fully as soon as circumstances will permit. Such an inquiry at all events serves to show how very little is yet known respecting some of the most important facts connected with the phenomena of life, and perhaps there is no more fruitful source of knowledge than to see and feel how little is accurately known, and how much remains to be learned.

---

II.—*Further Notes on Frustulia Saxonica.*

By W. J. HICKIE, M.A., St. John's College, Cambridge.

(Read before the ROYAL MICROSCOPICAL SOCIETY, January 5, 1876.)

PLATE CXXX.\*

BEFORE I make any remarks on Dr. Woodward's paper, I would ask permission to read a letter which I have just received from Dr. L. Rabenhorst, late of Dresden. His letter is as follows:

"VILLA LUISA, BY MEISSEN, December 27, 1875.

"Honoured Sir,—In reply to your favour of the 11th of this month, I must frankly acknowledge that I still faithfully remember that you showed me one evening in Dresden, and therefore by lamplight, *Frustulia Saxonica*, with its distinct and sharply outlined striæ-system; but I must also as faithfully and frankly acknowledge that I subsequently, and only lately, failed myself to resolve the longitudinal lines with one of Gundlach's strongest immersion lenses.† But then I must observe that I work only by daylight, and never by lamplight, out of regard for my eyesight.

"If now Dr. Woodward maintains that *Frustulia Saxonica* is identical with *Navicula crassinervis*, we must suppose that he is ignorant of one or other of them.

"Yours respectfully,

"DR. L. RABENHORST."

It will be observed here that Dr. Rabenhorst states that what I showed him was *Frustulia Saxonica*, and that I showed him both lines; for his expression, "Streifensystem," includes both lines.

I will now hand over Herr Seibert's photographs for your inspection, when I have first read his letter which accompanied them.

"OPTISCHES INSTITUT VON SEIBERT & KRAFFT, WEITZLAR,  
"December 20, 1875.

"Honoured Sir,—I herewith send you the two photographs you wished for, and hope they will enable you to convince Dr. Woodward that the lines do exist. They can be seen only by the help of direct sunlight; better, however, when the light is modified by some blue material. Of course, very good objectives are required for the purpose; but it is not the strength of the objective that conditions the visibility. One can see them with my No. 7; better, however, with my No. 8, one of which you possess. To be sure, the stronger objectives show the striæ more easily, but with no real advantage.

"Yours most respectfully,

"W. SEIBERT."

\* This Plate represents the two separate photographs sent by Herr Seibert, and labelled by him "Frustulia Sachs." The photographs have been enlarged twice in the Plate. Only one-half of the striæ of each frustule has been reproduced.

† This is easily accounted for. Dr. Rabenhorst told me himself, that his slides of *Frustulia Saxonica* were such poor things in comparison with the ones I showed him, that he should not care to let me see them.



[www.libtool.com.cn](http://www.libtool.com.cn)

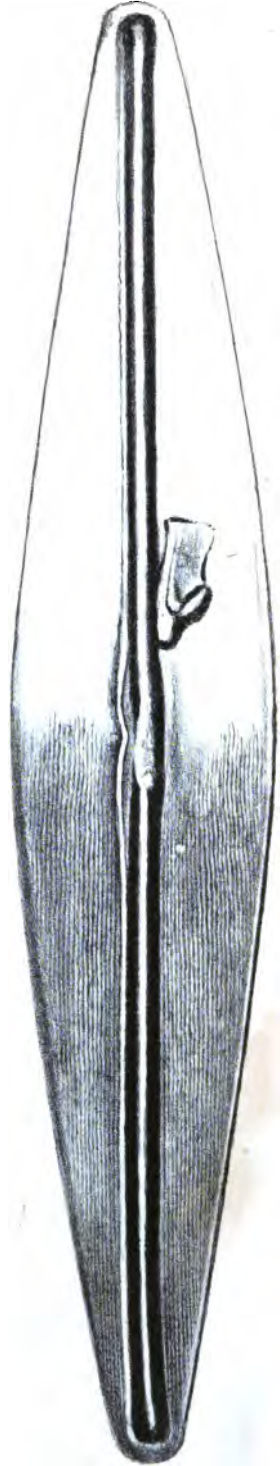
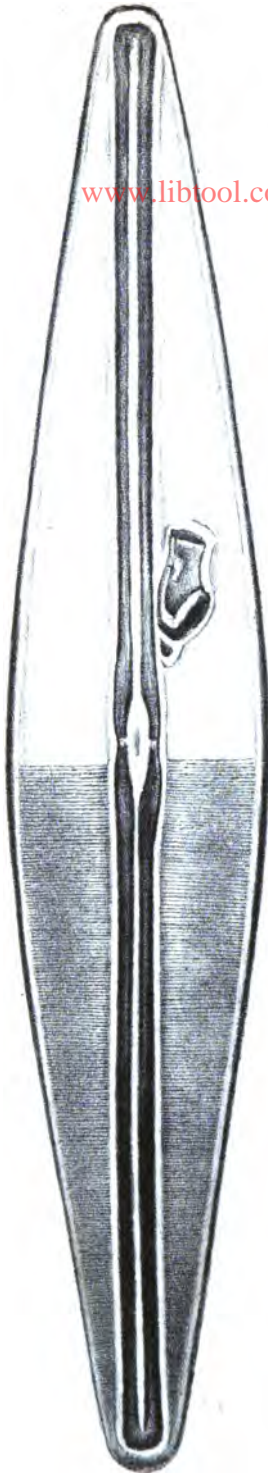

[www.libtool.com.cn](http://www.libtool.com.cn)

I may here remark that Dr. Woodward has altogether mistaken the purport of what I said. I questioned but little the possibility of his failing to resolve this or that series of difficult striæ with a double-nosed  $\frac{1}{16}$ th. I also quite as little questioned the amount of inference he might draw from so large a number as two slides, being mindful of the old proverb,

“But when one’s proofs are aptly chosen,  
Two are as valid as two dozen.”

What I said, or intended to say, was this, that I fairly believe I have spent more hours in the study of *Frustulia Saxonica* than Dr. Woodward has spent minutes, and that, during my residence in Germany, I had carefully gone over more than five hundred slides of *Frustulia*, and out of that number had selected two so coarsely marked, as to be easily resolved with a medium power.\* And I say now that, if any gentleman present will give himself the trouble of calling upon me, I will undertake to show him the longitudinal lines on either of those two slides, and that too without any suspicion of “diffraction phenomena.” Within the last few days I have purchased from Mr. Wheeler a third coarsely marked slide, which also allows its longitudinal lines to be easily resolved.

As for Dr. Woodward’s new criterion for distinguishing the real from the visionary lines, I would observe that, though it may be new, it certainly is not true; for I will undertake, in the sight of the gentleman who may visit me, to play the very same tricks with undoubtedly real lines that Dr. Woodward has with what he considers to be spurious lines, and will select for the purpose some diatom well known to all of us. Herr Seibert tells us that very good objectives are required to show the longitudinal lines. Dr. Woodward, on the other hand, has made it abundantly evident that very moderate objectives suffice to play diffraction tricks.

I shall not here raise any question as to lenses employed: the “personal equation” also need not detain us; for we are all aware that all microscopists have equal skill: it is only their lenses that differ; that is to say, every man has a better one than his neighbour.

“’Tis with our lenses as our watches; none  
Are just alike, yet each believes his own.”

Much also still remains to be learned, even about diatoms, and it is evident that Dr. Woodward has not learned it.

It has ever been held to be a wholesome exercise for every man

\* To give an instance in point: on Möller’s Probe-Platte may be found a specimen of what Möller, with his characteristic felicity of nomenclature, calls “*Nitzschia curvula*.” On my Möller’s Probe-Platte this diatom, either from the awkward way in which it is placed on the cover, or from the inherent difficulty of that particular shell, has given me more trouble than any other on that slide. And yet, on a slide of the very same diatom, given to me by Mr. Kitton, I can readily resolve the frustules, one after another, with an ordinary  $\frac{1}{4}$ -inch.

to ride his own hobby, whether that be "diffraction phenomena," or any other; only he must take care that his hobby do not throw him. But Dr. Woodward has ridden his hobby at a pace which will hardly be salutary for his reputation. If his theories be correct, and if the results of assisted vision be so utterly untrustworthy, what becomes of the microscope as an aid in scientific research? or is his meaning only, that microscopists on *this* side of the Atlantic must not presume to publish any opinion without licence first obtained under his broad seal, but must in all cases telegraph their doubts to Washington, and wait in patience for the Washington *imprimatur*?

I think also that his suggestion, that men of such eminence as Rabenhorst, Lindig and Seibert are incapable of steering clear of so well known an obstruction as diffraction, is—to put it mildly—in questionable taste.

Indeed, it would seem as though Dr. Woodward cared more on which side of the Atlantic a thing is said, than for the statement itself.

In Mr. G. W. Morehouse's article "On Microscopic Powers,"\* we read: "First-class  $\frac{1}{2}$ ths to  $\frac{1}{3}$ ths are showing the transverse striæ of *Amphipleura pellucida*, *Navicula crassinervis*, *Frustulia Saxonica*, and *Nitzschia curvula*. The  $\frac{1}{3}$ th reveals longitudinal lines on all these, much finer than the transverse, and evidently genuine. Under favourable conditions the resolution into the so-called beading is distinctly effected on the first three named." And in another article, contributed to the 'American Naturalist,' and reprinted in the 'M. M. J.,'† the same gentleman says: "*Frustulia Saxonica*. In addition to my observation of longitudinal lines upon this test and resolution into dots, it may be worth noting that, even with lamp illumination, the  $\frac{1}{3}$ th has displayed the transverse much clearer than they appear in Dr. Woodward's photograph.‡ This is one of the most difficult test diatoms thus far studied, ranking but little easier than *A. pellucida*, *N. crassinervis*, and *Nitzschia curvula*." It will be seen here that Mr. Morehouse has anticipated me in saying all I had to say in my letter of last July, and has said it with more particularity. He has not only seen genuine longitudinal lines on *Frustulia Saxonica*, but has resolved them into dots. He further states that the longitudinal lines are "much finer than the transverse." He also,—as do all men who know anything about the matter,—regards *Frustulia Saxonica* as *not* identical with *Navicula crassinervis*; and, that there might be no mistake as to the tendency of his remarks, he has expressly referred to Dr. Woodward's paper in the 'Lens.'

\* 'M. M. J.,' vol. x., p. 150.

† Vol. xii., p. 23.

‡ 'Lens,' vol. i., p. 197.

Of the 'American Naturalist' I know nothing; and even of the 'Lens' itself I have seen only the small sheet forwarded by Dr. Woodward on the 27th of last October. Mr. Morehouse's papers also did not come under my notice till long after my letter was written, as I am in the habit of obtaining the back volumes of the 'M. M. J.' very irregularly and at uncertain intervals. It now rests with Dr. Woodward to explain how it happens that, while he silently acquiesced in Mr. Morehouse's strictures, a courteous letter from this side of the Atlantic could draw from him two such paragraphs as those I shall proceed to quote from his present paper.

On page 274 he says: "It will be observed that I did not, in my 'Note,' speak generally, as Mr. Hickie does, of what 'Dippel and others' fancied they saw, but specifically of the longitudinal striæ of Dippel." . . . "In my 'Note,' then, I spoke only of the *longitudinal striæ of Dippel*, but now, in response to Mr. Hickie's letter, I willingly express my belief that the longitudinal lines which he describes are of the same character."

That is to say, I ought to have spoken "specifically," as he did, and with all fulness of knowledge, in July, about a matter of which I neither had, nor could have, any knowledge till the 27th of the following October, when he himself sent me the information. Of course, the idea suggested to his readers is that I have been tampering with the text of his article by interpolating "*and others*," from a desire to make it appear that his views are opposed to those held by microscopists in general, while they really are at variance only with certain rash statements put forth by an obscure German called Dippel.

Again, on page 279 he says: "Mr. Hickie asserts that there is a difference, but does not make clear in what the difference consists. I should be happy to learn further from him on this head, if he has anything to teach."

Just so, in the Prussian "Reddymadasy," opposite the picture of a wine glass, we find,\* "This is a wine glass. Out of this folks drink wine—when they can get it."

Elsewhere also he has invited me to produce fresh evidence for his consideration. This I must decline to do, as there would be little profit in arguing with one whose fundamental axiom seems to be, like Hume's, that "No amount of evidence is sufficient to prove such and such things."

My own letter was written in all good faith and sincerity, and was rather an indirect expression of my high estimate of Dr. Woodward himself, than any correction of erroneous views, about which I

\* See page 78 of the 'Hand-Fibel'; fünfundreissigste Auflage. Preis ungebunden 4 Sgr. Berlin, 1872. A respectable volume, though it omits the important fact recorded by Dr. Woodward, that *schwach gezeichnet* is the German for "very pale."

really did not care two pins ; and I certainly did expect a different answer ; for though it is impossible not to admire the amazing dexterity with which his has been put together, it is equally impossible not to perceive that its object is rather victory than any search after truth, and that scientific truth is an object quite secondary to his desire to bar the way against fresh evidence by the antecedent prejudice of " diffraction phenomena."

It is indeed a clever paper, but its cleverness is in its attorneyship ; and its only effect will be to lay him open to the reproach, that his reputation for infallibility is dearer to him than the truth.

And now, as all here have probably examined Dr. Woodward's photographs by this time, if any of you will take upon you to declare that they represent to you the veritable *Frustulia Saxonica*, as it is known in Germany, I will say no more.

For my own part, the more I look at them, the more I am puzzled to make out for what purpose they were made or sent.

Only on two of them,—those marked with the letters A and F,—can I discern any resemblance.

As for the others,—those marked with the letters B, C, D, and E,—they may represent anything, or nothing.

And here, *à propos* to their *very peculiar* colour, I would remark that, if we, *purely for argument's sake*, take them as *Frustulias*, we shall find ourselves in something like a dilemma ; for those who are in the habit of working on *Frustulia Saxonica* know well that, of the whole number of frustules on a slide, more than two-thirds are usually of a rusty brown colour, while the rest are of a clear French white ; and that it is only the latter which are capable of being resolved. The rusty ones they may as well let alone.

They will also notice that, if they happen to focus too deeply, or to set the adjustment-screw far wrong, the result will be to convert the previous clear French white colour of the shell they are looking at into the dingy rusty colour which is natural to the irresoluble ones.

So that, if, as I said before, we imagine for the nonce his to be *Frustulias*, we are driven to the conclusion that, either (1) he does not know what frustules he ought to try at, or (2) that his photographs have all been made with the objective out of focus.

I myself adopt the first.

We need not here discuss the goodness or badness of his slides : his fault has been that he mistook one slide for another.

One gentleman has gone at once to the root of the matter by asking, " But what is *Frustulia Saxonica* ?" As some help towards solving this riddle, I have brought with me two unquestionable slides of that diatom, which I will ask some of you to put under the microscope and to exhibit for me. A careful examination will show you, on the very same slide, some specimens even longer

and narrower than the one represented on Herr Seibert's photographs, which he has so thoughtfully, lest we should make a mistake, labelled "*Frustulia Sachs.*," and some, again, which are much shorter, and, comparatively, twice as plump; so that an opinion based on an examination of one specimen may be upset by a glance at the next. If now we remove the slide of *Frustulia*, and substitute a slide of "*small Rhomboides*," that is, such a one as that presented to me by Mr. Kitton, the observer will be somewhat puzzled to tell which slide he is looking at; for there also he will see some as long and as narrow as Herr Seibert's, though—strange to say—the short and plump ones are in a large majority, which is not the case on the slides of *Frustulia Saxonica* by Rodig and Möller, which I produce.

On "*large Rhomboides*," however, and especially on that known as "*Bennis Lake Rhomboides*," we can, indeed, see a difference; for here we observe a palpable angle at the broadest part, and the median line seems to run right on to the terminal margin, while the central knot is much more conspicuous.

But, as regards our "*small Rhomboides*," a repeated comparison of Mr. Kitton's slide of this species with indubitable slides of *Frustulia Saxonica* compels me to do that which Dr. Woodward has declined to do, namely, to retract a previous erroneous statement, and to confess that I am unable to state where "*Frustulia Saxonica*" ends and our "*small Rhomboides*" begins, and that, in spite of casual differences here and there in colour and in their resolution, they really are the same thing under different names; so that, if we call our small *Rhomboides* *Frustulia Anglica*, and its Saxon congener *Frustulia Saxonica*, and Dr. Woodward's *Frustulia*, when he finds it, *Frustulia Woodwardia*, we shall, I suppose, have satisfied all parties.

I will further remind you of a few simple facts. Dr. Rabenhorst discovered a certain diatom in Saxon Switzerland and named it *Frustulia Saxonica*. De Brebisson also, as I understand, discovered a certain diatom and named it *Navicula crassinervis*, and did so under the impression that what he so named was something totally different from what Dr. Rabenhorst had called *Frustulia Saxonica*. Dr. Rabenhorst, again, in the letter I read to you, says expressly, that he who identifies these two diatoms, must be ignorant of one or other of them.

Now, if there be any two greater Continental authorities on this point than Dr. Rabenhorst and the late De Brebisson, I should like to know who they are.

I have now said all that I intended to say, and have said it at some length, as I do not intend to revert to this subject again, either in reply to any future remarks of Dr. Woodward's, or in reply to any other person who may care to reopen the question.



III.—*On the Characters of Spherical and Chromatic Aberration arising from Eccentric Refraction, and their relations to Chromatic Dispersion.* By Dr. ROYSTON-PICOTT, M.A., F.R.S., F.C.P.S. [www.libtool.com.cn](http://www.libtool.com.cn)

THE paper which I last had the honour of submitting to the Royal Microscopical Society treated of the characters of spherical and chromatic aberration, which are identical. In that paper, none of the statements of which need correction, the peculiar spherical aberrations of red and blue light were scrutinized and their actual spherical (i. e. their marginal) aberrations calculated approximately.\*

On referring to Professor Littrow's paper on "Double Object-glasses," the reader will see at pages 240, 241,† that he says,

"The principal of these properties (in a proposed double object-glass) is that all rays, red as well as violet, incident near to or far from the axis shall all unite after the fourth refraction in one point of the axis." That is to say, that these coloured rays, whether marginal or central, shall at last have a common focal point.

He then proceeds to test in section (7) this union of all the rays considered, namely, violet, red, and mean rays by his formulæ.

He takes the case of crown glass and flint glass with indices 1.53 and 1.58 respectively and  $\frac{3}{4}$  for the ratio of their dispersions. He then calculates the points at which the violet and red rays cut the axis by means of the formula for spherical aberration depending on the radii of the lenses and their refractive indices.

In order to find whether the dispersion of colours has been destroyed, he determines the points at which the red and violet rays cut the axis.

He gives several examples of determining the points at which the red, violet, and mean rays cut the axis after refraction through the object-glass, of which I beg to subjoin an example in which the aperture of object-glass is 9.62 inches and focal length 5 feet (a most extraordinary short focal length).

For this construction he says, page 249, "I found the focal length (proportions used)

For mean rays incident at an angle of 10°	2.30375	Chromatic
For mean rays incident near axis (i. e. geometrical focus)	2.30379	aberration.
For violet rays .. .. .	2.30379	(0.00000)
For red rays .. .. .	2.30378	(0.00001)

\* The principal focus varies with each change in the refractive index, i. e. with the colour, and this would introduce further small changes neglected in the Appendix to the last paper.

† Vol. iii., 'Mem. Roy. Astr. Soc.'

Professor Littrow concludes his paper by saying,

“The preceding calculations are therefore equally simple and exact, as they leave the beaten path of finding the spherical aberration by an approximate expression, and determine this aberration for any angle however large with perfect accuracy . . . .”

It would be of no interest to the Fellows to quote the whole formula used by Littrow as an improvement on Sir J. F. Herschel's method, but I may be excused for quoting another example, as it bears very strongly on the principal feature of these papers. He says,

“*In order to find how far the chromatic aberration has been destroyed, we have (if  $B'$  be focal length and  $n, n'$  indices of refraction)*

$$\frac{1}{B'} = \overline{n-1} \left( \frac{1}{r} + \frac{1}{s} \right) + (n' - 1) \left( \frac{1}{r'} + \frac{1}{s'} \right) + \frac{\overline{n-1}}{nr^2} \cdot d''$$

when the radii of the lenses are  $r$  and  $s$  and  $r'$  and  $s'$ , and  $d$  the thickness of the first lens: and this equation is absolutely the expression for finding the aberration of two lenses for each kind of coloured light tested.

The same formula is employed over and over again to test the amount of spherical and chromatic aberration introduced by the lenses: and hence in this respect the characters of the two are absolutely identical.

In standard works on optics, chromatic aberration and spherical are treated for convenience as distinct things. It may be noticed, however, that Professor Potter has discarded the term chromatic aberration and employs the term *longitudinal dispersion*, also used by Coddington in 1831.

Thus, in Art. 84, p. 113, pt. i., 3rd edition, Professor Potter's proposition is thus worded:

“*To find the longitudinal dispersion and least circle of chromatic dispersion in a given lens.*”

He then finds the longitudinal dispersion for rays whose indices are different (such as red and violet), which is simply the chromatic aberration along the axis of the coloured rays.

Further on he says the condition of achromatism is that  $v$ , i. e. the distance of the focal point from the last lens shall remain the same for all colours.

Inasmuch therefore as the longitudinal dispersion or chromatic aberration is obtained from the spherical equations, in other words, as the particular coloured light entering a given lens is then subjected to the spherical laws of refraction in precisely the same way as homogeneous light would be—so far their chromatic and spherical aberration are identical in character.

The question turns entirely upon the definition of the terms

used. Potter's term, longitudinal dispersion, is precise and self-evident. The term chromatic aberration has been so loosely employed as to give rise to sufficient confusion.

Thus chromatic dispersion is simply applied to denote the various ways in which the colours in a solar spectrum are dispersed over its whole length, which vary in their degree, position, and intensity, according to the nature of the light and prisms employed.

Again, in the standard optical works the chromatic aberration calculated, is merely the variation of the focal length for the central rays forming what is called *the geometrical focus*, which, mathematically speaking, is used only for an infinitely small axial pencil of rays passing through the exact centre of the lens in question: but the chromatic aberration of a given coloured ray passing through the periphery or marginal area of the lens is altogether omitted, although implied in the fundamental formulæ.

Further, the popular canon in achromatics, that achromatism is determined by the condition that the dispersions of the two achromatizing lenses must simply be in proportion to their focal lengths, is a rough formula, only true for the geometrical focal lengths: for it is entirely founded on the fundamental value of the focal lengths of the central rays, and even the thickness of the lenses is entirely neglected in this popular canon, and only two colours can be united for the dispersions of the two sets of rays chosen.

Opticians have determined for themselves the fallacy of this canon for delicate purposes, and of the two necessary evils chosen the least. In forming a telescope of two glasses, they find minute double stars are shown most distinctly when the secondary spectrum or uncorrected colour is faintly purplish, or claret colour.

On referring to Brewster's treatise on Optics,\* the identical character of chromatic and spherical aberration is well implied. He says, p. 79,

"In treating of the progress of rays through lenses, it was taken for granted that the light was homogeneous, and that every ray that had the same angle of incidence had also the same angle of refraction, or what is the same thing, that every ray which fell upon the lens had the same index of refraction. The observations in the preceding chapters have proved, however, that this is not true, and that in the case of light falling upon crown glass there are rays with every possible index of refraction from 1.5258 to 1.5466, the index of refraction for the violet rays."

"The extreme red rays (marginal) will have their focus in  $r$ , whilst the extreme marginal violet rays whose index of refraction is 1.5466 will have their focus in  $v$ . The distance  $vr$  is called the *chromatic aberration*." And I may remark, there is

\* Lardner's 'Cab. Cyclop.,' "Optics," by D. Brewster, LL.D., F.R.S., afterwards Sir David Brewster.

no way of finding this mathematically, except by the calculation of the aberration of the red and violet rays from the spherical formula involving their indices of refraction and radii of surfaces, and thickness. [www.libtool.com.cn](http://www.libtool.com.cn)

The *chromatic aberration* is finely shown by a very large burning-glass. The author possesses one of 8 inches in diameter. If the whole be covered up except a half-inch rim, the image of the sun will be seen of different colours on a semi-transparent screen held at the various foci. Each colour produces its own brilliant focal image in order, and their exact positions measure in some degree the dispersion of the glass. If now the whole be covered up except an inch in the centre, the order will be the same as before, but their former positions are altered. The difference between the positions of the red image of the sun, for instance, is the spherical aberration of the red for the given glass and curvature: and the variation of the position of the violet image of the sun for the marginal and central rays of the burning-glass is the spherical aberration of the violet; and is absolutely identical with the spherical aberration of the marginal rays of that kind of light which has the same refractive power as the red or violet in question.

The chromatic dispersion, or, much better, the dispersion, is best shown by the spectroscope, formed of several accurately constructed symmetrical prisms, and can only be very correctly measured by using *plane* instead of spherical surfaces (very perfectly formed to bend the rays). Barlow succeeded in determining the chromatic dispersive power roughly by measuring the distance to hundredths of an inch, by which lenses of different materials formed rude achromatic images when separated by a measurable interval, the image of a black cross on white paper being used. This method I take the liberty to call rough, as it cannot be compared for a moment to the delicate method of measuring wavelengths as employed in the best spectroscopes.

The very curious laws of dispersion revealed by this modern instrument, depending both on the intrinsic quality of the light and the media through which it is transmitted, can be investigated now under circumstances of unprecedented precision and advantage. The detection of the velocity of motion, for instance, of Sirius as receding from or approaching the sun, is an example of the most subtle process of analysis yet exhibited to mankind. Dispersion (and its correlations) is now one of the most interesting departments of modern physics.

There can be no doubt that every case of marginal aberration in a coloured ray, though identical in the laws of its refraction with what is called spherical aberration, has yet further qualities dependent on its source. Thus the aberrations of the blue rays pro-

duced by oil of cassia enclosed between two concave lenses, will have a very different relation to that of the red ray, as compared with the aberrations of sulphuric acid similarly enclosed.

Indeed, the variations of the chromatic and spherical aberrations go, as it were, hand in hand. Spherically considered, their characters are identical, but their qualities depend upon the nature of the light and the media through which it is transmitted.\*

(To be continued.)

---

*Additional Note. January 14, 1876.*

I have been led to the consideration of the subject in consequence of the very imperfect notions and ideas afloat regarding this very fundamental principle in optics. The advanced student of science in general is becoming daily better acquainted with its general laws. It was an unfortunate circumstance that for novices it was found convenient to employ the figment that light in optics might be considered homogeneous for the purpose of simplifying optical formulæ; this veritable scholastic sham should have been more carefully guarded and explained. The result upon general readers has been lamentable. Spherical aberration, the grand difficulty of opticians, is thought to belong only to a pure homogeneous ray. Chromatism is represented as cured by regulating the foci of lenses; whilst chromatic error is represented as having nothing whatever to do with spherical aberration; spherical and chromatic aberration being thus made distinct and as it were independent, is pernicious to optical science, as being utterly false. In the standard optical works chromatic aberration is only treated of centrally: the excentrical is altogether omitted. The question is one of the most important possible in fundamental optics. [I may further remark to-day, February 12, that spherical aberration has no existence for the central ray, but chromatic aberration displaces the focus of the mean central rays. But the moment a coloured ray passes marginally or excentrically, it that instant obeys the laws of spherical aberration: and has its identical characters.]

Dr. Parkinson says, in his preface to 'Optics,' that the work is a new edition of Griffin's 'Optics.' To the latter gentleman, both the present and former paper have been submitted, and from him I

\* Suppose a violet ray to pass through the margin of a lens and also through a small central aperture, then its variation in focus is identical with its spherical aberration; and if also a red ray pass similarly, the resulting variation in focus is also the aberration due to the marginal curvature, so that these variations are identical in character as being spherically produced and spherically calculated.  
—(Note added Feb. 12.)

have received the following letter this morning in reference to the present paper, which I am privileged to insert here :

[www.libtool.com.cn](http://www.libtool.com.cn) OSPRINGE VICARAGE, FAVERSHAM,  
12 January, 1876.

“ Dear Dr. Royston-Pigott,—In the enclosed paper, on which you encourage me to express an opinion, I see nothing to modify or alter. I understand your view to be this. The books treat of chromatic aberration as if there were no spherical aberration. This is hypothesis which nature does not accept. Therefore the true and exact way is to examine an exterior ray in its entire straggling—

“(1) From the geometrical focus in virtue of what we call spherical aberration.

“(2) From its fellow constituents of the unrefracted ray of white light in consequence of chromatic aberration.

“Both of these demand consideration as coexistent causes of a pencil not converging exactly to a point.

“This you seem to me to have accurately expressed in the paper which I now return.

“ Believe me to be faithfully yours,

“ W. N. GRIFFIN.”

I have received letters from equally distinguished mathematicians, approving of my first paper on this subject, which I have placed in the hands of our Honorary Secretary, Mr. Slack. I am allowed to add that Mr. Griffin approves the first paper also, as containing “nothing inaccurate in its statements.”

---

#### IV.—*On Staining and Mounting Wood Sections.*

By M. H. STILES.

THE staining of sections of vegetable tissues so greatly assists the microscopist who engages in the study of their structure, that any improvement in the preparation and mounting of such sections will, I feel sure, be eagerly welcomed.

During the past few months I have made many experiments in connection with this subject, and the results obtained are so good, and the method so simple, expeditious, and, in some respects, new, that I think I shall be justified in publishing a short outline of it.

The cutting of sections of woody or herbaceous stems and roots does not usually present much difficulty; simple maceration in cold or tepid water, or, in the case of some dried specimens, in a mixture of equal volumes of spirit of wine, glycerine, and water, will

generally be sufficient preparation for the section machine. After cutting, soak the sections in water containing about 10 per cent. of spirit until the tissue is freed from air, or, if convenient, put them for a few hours under the exhausted receiver of an air-pump.

In order to get the best results with staining liquids, the sections, if at all dark-coloured, should be bleached. A very cheap and effective bleaching liquid may be made by mixing  $\frac{1}{4}$  ounce of chloride of lime with a pint of water, shaking occasionally for an hour, and after allowing the sediment to subside, decanting the clear solution. Unless the tissue be very dark and dense, from six to twelve hours' immersion in this liquid will be sufficient. It is not advisable to use a stronger solution, and in any case the process of bleaching must be watched and arrested when complete, or the objects may become too tender to bear the subsequent preparation for mounting. After pouring off the bleaching solution, wash the sections by soaking them for at least twelve hours in water, changing frequently, and finishing with distilled or filtered rain water.\*

Previous to staining they should be placed in spirit for about an hour. A small beaker is a convenient vessel for this and the subsequent operations, and to avoid injuring the sections, they need not be removed from this beaker until ready for mounting.

Of the aniline colours in general use, magenta and blue give the most pleasing results. The magenta staining liquid is made by dissolving 1 grain of the finest cake or crystal magenta in 2 ounces of spirit; the blue dye is prepared by dissolving  $\frac{1}{2}$  grain of pure soluble blue in 1 drachm of distilled water, then adding 10 minims of dilute nitric acid and sufficient spirit to measure 2 ounces. It is a convenient plan to prepare stock solutions eight times the strength given here, and dilute them when wanted.

The time required to stain different tissues varies, so that no special period can be fixed: from twenty to forty minutes will generally be sufficient, but the objects should be examined every few minutes to guard against their becoming too deeply coloured. After pouring off the staining solution, wash the sections three or four times with spirit, drain them for a few minutes by inverting the beaker containing them over a piece of blotting paper, and then soak them in oil of cajuput for an hour: at the end of this time remove the oil, drain on blotting paper as before, then immerse the sections in turpentine; after they have remained in this liquid for an hour remove it and add fresh. The sections are now ready for mounting in balsam or dammar, which operation should not be long delayed.

\* The elimination of the chlorine will be much facilitated by placing the sections, after removal from the bleaching liquid, in a solution of hyposulphite of soda (1 drachm to 4 ounces of water) for an hour and then washing as directed.



Dr. Beatty has recommended the staining of sections of wood in two colours. This may be accomplished by macerating for twenty to thirty minutes in the magenta solution, washing with spirit, then treating with the blue dye for five to ten minutes, well washing, and afterwards soaking in oil of cajuput and lastly in turpentine.

The two kinds of tissue—vascular and cellular—seem to have a special selective power with regard to the colours employed; the cellular more readily taking blue than red, and the vascular to a great extent retaining red when subsequently treated for a short time with blue. Thus a transverse section of wood carefully double-stained will have the vessels, wood cells, and liber tissue more or less red, and the pith, medullary rays, and cellular tissue of the bark blue or violet.

Independently of stained wood sections, this process of preparing objects for mounting in balsam or dammar admits of extensive application. It is a difficult matter to thoroughly dry a delicate tissue without injuring and in some cases almost obliterating its structure, and it is well known that an imperfectly dried specimen will not make a satisfactory object when mounted in balsam or dammar.

By the method here indicated, tissues far too delicate to bear the ordinary preparation for mounting in these media, can be successfully treated, and a good result obtained.

I believe the use of oil of cajuput for this purpose is entirely new, and, as the oil is not very generally known, the following notice of its source and properties may be interesting. Oil of cajuput is distilled from the leaves of *Melaleuca minor*, a plant growing in the Molucca Islands. It is very limpid, of a pale bluish-green colour, and has a strong but not unpleasant odour. It is miscible with rectified spirit\* and turpentine in all proportions. This oil is superior to the oils of cloves and aniseed in being more limpid, considerably cheaper, and in not staining the tissue treated with it as does oil of cloves.

\* Throughout this process of staining, &c., an efficient substitute for rectified spirit will be found in methylated spirit that had been digested with animal charcoal and carbonate of magnesia,  $\frac{1}{2}$  ounce of each to the pint, for two or three hours, and then filtered.

V.—*On a Mode of Viewing the Seconds' Hand of a Watch through a Beetle's Eye.* By Dr. WHITTELL.

IN one of the earlier numbers of the 'M. M. Journal' a writer described some interesting results produced by experiments on a beetle's eye as seen under the microscope. Amongst other facts he mentioned that the movement of the seconds' hand of a watch could be made visible through each of the numerous lenses of which the eye is compounded, but as he had only read of the experiment, he was unable to explain the mode of procedure. In looking about for something interesting to exhibit at the late soirée of the Adelaide Club, I made many experiments with a view to produce the above-named result, and after numerous failures I hit upon the following simple but effective plan, which I venture to submit, with the hope that it may be of some use to the readers of the Journal.

Take a watch with a white face, take out the front glass, and remove the hour and minute hands. Paste over the face of the watch a piece of dead-black paper with a round window cut in it, so as to leave nothing exposed but the small circle in which the seconds' hand rotates. Place the watch on the front of the mirror of the microscope, and condense the light of a strong flame on the small white circle that has been left exposed. Reflect this light through the beetle's eye, previously placed on the stage, just in the same manner as if the ordinary mirror were being employed. Bring the eye into focus, and then gradually draw back the objective by means of the fine adjustment until the images of the watch hand appear. At first these will probably be dim, but by varying the inclination of the watch and careful adjustment of the light the observer will at length obtain a bright and distinct image through each lens of the eye. The nearer the watch can be brought to the stage without cutting off light from the condenser, the larger will be the image. Any power may be used from  $\frac{1}{8}$  to  $\frac{1}{2}$  inch, but I prefer a  $\frac{4}{10}$ th, with a No. 2 eye-piece. Under this power the images are sufficiently enlarged, and a good number of them are included in the field. The eye may be mounted in balsam, but I think I have obtained better results from one specially prepared and mounted in glycerine.

ADELAIDE, SOUTH AUSTRALIA.

## PROGRESS OF MICROSCOPICAL SCIENCE.

*Examination of Coal for Diatoms.*—We have received a note from Count Castracane, calling attention to an accidental error in the account we gave in the last December number of this Journal\* of his method of examining coal for diatoms. The ash should be heated with hydrochloric acid, and chlorate of potash added from time to time—not caustic potash, since, of course, this would only tend to neutralize the acid, or, if added in excess, would dissolve the diatoms themselves.

A *New Phyllopodous Crustacean* is described by Mr. W. Lockington, who read a paper recently before the San Francisco Microscopical Society on the subject.† He said that the animal, which is nearly allied to *Artemia salina*, the inhabitant of the salt-pans of Lymington, inhabits the Great Salt Lake of Utah. The inferior antennæ in the male are two-jointed. The basal joint, with a short rounded process (in *Artemia salina* this is conical); the joint itself thick and rounded; the second or terminal joint broad and fan-shaped, and the whole antennæ somewhat resembling the mandible of a stag-beetle in general appearance; the inferior antennæ in the male and both pairs in the female slender and filiform; thorax with eleven pairs of branchiæ eyes on short peduncles; abdomen nine-jointed; the end joint two-lobed, each lobe bearing a variable number of setæ (4–6); colour a dark purplish brown. From the locality in which it was collected, it is proposed to name the species *Artemia Utahensis*.

*The Development of Lepas fascicularis and the "Archizoëa" of Cirripedia.*—Dr. R. von Willemdoes-Suhm sent to the Royal Society a valuable paper on the above subject, which will doubtless be fully published in the 'Philosophical Transactions.' The following abstract is given of it in the last number of the 'Proceedings of the Royal Society,' No. 165.

### I. Development of the egg and of the youngest Nauplius.

The conclusions to which an investigation into the development of the ovum, and into the changes which occur in it after its formation up to the time when the *Nauplius* comes out, has led are the following:—1. The youngest eggs, seen in the cæca of the ovarian tubes, are transparent cells with nucleus and nucleolus. 2. The germinal vesicle, as well as the ovum, grows by taking up elements of yelk. 3. All the ova found in the ovary of a barnacle are in the same stage of development. When mature ova are to be seen in the tube, small undeveloped ova may be seen here and there in the cæca, which act very likely as mother-cells for further breeding purposes. 4. The spermatozoa, when fully developed, are simple hair-like filaments. 5. The mature ovum, as contained in the breeding lamellæ, shows no trace of the vesicula germinalis nor of its nucleolus. Some highly

\* Vol. xiv., p. 291.

† 'Cincinnati Med. Journal,' January.

refractive granules may be seen here and there among the yelk-globules. The ovum is oval in form. 6. The segmentation is very irregular, but seems to be complete. 7. As soon as the segmentation begins, large transparent cells are seen separating themselves from the yelk-globules, and increasing in number as the segmentation goes on. 8. These cells form a blastoderm round the yelk. No primitive streak could be seen; but its presence is not denied, as the object is not favourable for these observations. 9. The blastoderm loses its cellular structure and gives way to a granular skin. On both sides of a longitudinal groove three pairs of appendages begin to be visible. 10. The test of the ovum extends as the embryo develops. The latter is very likely still enveloped by a thin blastodermic cuticle, which is clearly visible at the ends of tail and antennæ, when it comes out. 11. The development of the *Nauplius* in the ovum of this *Lepas* shows very much the same stages as those described by Buchholz in *Balanus improvisus*.

## II. The Nauplius stages.

1. The *Nauplius* of *Lepas fuscicularis* has, when leaving the egg, a length of 0.35 millim. It moults at least five times, and has before throwing off for the last time the Naupliar appendages a length of 12 millims. 2. The first stage of the *Nauplius* has been seen by Darwin, who describes it, and also by Burmeister. 3. After the first two moults the *Nauplius* gets a large dorsal spine and enters a series of stages, one of which has been described in another *Lepas* by Dohrn as *Archizoëa gigas*. 4. Reasons are given why *Archizoëa gigas* is nearly certain to be the *Nauplius* of *Lepas australis*, a species closely allied to *Lepas fuscicularis*, and representing it south of the equator. *Archizoëa gigas* was caught, together with the large *Cyprides* of *Lepas australis*, during the 'Challenger's' Antarctic cruise. 5. The tail and the caudal spine of the newly hatched *Nauplius* are pushed in like the tubes of a telescope, and covered by a thin cuticle, which may be the blastodermic one. The same envelops also the lateral horns, but has not been seen at the end of the appendages. The carapax is as yet quite smooth, with the lateral horns hanging down. 6. After the first moult the tail and its spines, which have been pushed out, have a considerable length, and the lateral horns are erected. Only a single pair of small spines is to be seen on the carapax. The glands inside are unicellular. 7. The *Nauplius* after the second moult has, besides the dorsal spine, a series of processes all round the edges of the carapax, to which the unicellular glands send their ducts. Besides the oesophagus, two glands, which formerly were indicated by an agglomeration of cells, become visible. These glands are very likely those which, in the *Cypris* stage, terminate in the sucker of the antennæ, and are known under the name of cement-glands. Mouth and anus are present. One pair of movable spines on the tail. First "*Archizoëa* stage." 8. Length of *Nauplius* in the fourth stage 6 millims. Three or four movable spines on the tail, with the six of the next stage shining through the chitinous coverings. The glands of the carapax are in connection with nerves, and present a large network. No nerve-terminations on the lateral horns nor on the feelers.

All the processes of the carapax, as well as the lateral horns, have openings at the top for letting out the secretions of the glands. 9. Length of *Nauplius* in the fifth and last stage 12 millims. Six movable spines on the tail. Large masses of fat are assembling in the carapax, and the *Cypris*-shell is forming underneath it. The first pair of appendages develops inside the antennæ of the *Cypris*, the sucker being formed in the fourth joint, the second of the future antenna. Large compound eyes become visible on both sides of the central eye. 10. The carapax of the *Nauplius* has now a diameter of 2 millims. The appendages are very much like those of *Archizoëa gigas*, in which Dohrn, however, has taken the third pair of appendages for the second, and the second for the third. 11. A specimen of the supposed larva of *Lepas australis* (Dohrn's *Archizoëa gigas*) is figured in the stage just before the metamorphosis into the *Cypris* stage takes place; the two large compound eyes have already developed.

### III. The *Cypris* or pupa stage.

1. The *Cypris* of the Atlantic, *C. fascicularis*, has been already described by Claus, who has established the homology of its parts with the Copepods. 2. Darwin has described the very large *Cypris* of *Lepas australis* (length 3 millims.), which is in every way similar to that of the present species—a further proof of the probability of the suggestion that Dohrn's large *Nauplii* are the larvæ of that species. 3. Our *Cypris* has a length of 1.3 millim. 4. A description is given of the antennæ with the suckers and their glands, the development of which from the glands in the labrum has been mentioned already. The parts of the mouth (small labrum and three pairs of maxillæ and maxillipeds) and the natatory feet, as well as the caudal appendages with the anus at their base, are figured and described. The organs of sense, the digestive organs, and the shell-gland, which is now very conspicuous, offer scarcely anything that has not been seen already by Darwin and Claus in the *Cyprides* of the different species of *Lepas*.

### IV. The metamorphosis of the *Cypris* into the young *Lepas*.

1. The pupæ are chiefly caught at the very surface of the sea, where they swarm round the dead *Veilellæ*, on which they settle. They rarely take to a colony of old barnacles. 2. Soon after settling the new cirri are formed underneath the natatory feet, the head grows out, the eyes are absorbed, and under the *Cypris*-shell the primordial valves of the young *Lepas* appear, which persist during its whole life. The *Cypris*-shell, with the old natatory feet, is then thrown off. 3. The young *Lepas* begins to form the complete shell, and fastens itself more and more by the copious secretions of its glands, which run through the outdrawn and enlarged head into the fixing antennæ. 4. The cirri of the young *Lepas* develop a larger number of joints, the shell begins to lose its transparency, the body inside turns over a little, as has been described by Darwin, and the young *Lepas* is complete.

The Minute Structure of *Lucernaria octoradiata* has been very fully made out and published before the French Academy (No-

ember 8, 1875) by M. Korotneff, an abstract of whose essay appears in the 'Academy' (January 1876). He finds the body of these creatures composed of four layers: (1) an ectoderm covered by a cuticle; (2) a gelatinous layer; (3) an elastic membrane; (4) the endoderm. At the base of both endoderm and ectoderm are cells which transform themselves into nematocysts, or gland-cells. The gelatinous layer and the *membrana propria* are traversed by elastic fibrils which are prolongations of endodermic cells. Two sorts of muscles are found, longitudinal and circular, the latter always forming an external layer. The longitudinal muscles are represented by four trunks, which commence at the bottom of the foot. In the middle of the body each trunk divides itself into two branches, and each branch enters a bundle of tentacles. A layer of muscular fibres is also found in the walls of the peristome, and buccal tube. The circular muscles are found round the mouth, along the margin of the body, and in the tentacles. Each fibre is a simple cell, containing a highly refringent fibril. A single fibril sometimes traverses a series of connected cells.

Schultze regarded the bristles of the urticating organs (*cnidocils*) as instruments of touch. M. Korotneff finds the tops of the tentacles covered with the urticating *nematocysts*, each one placed in a cell which carries its bristle (*soie*). The cellule is extended into a long fibril, which traverses a bipolar or a multipolar cell, and terminates in a little peduncle that penetrates the *membrana propria*. These multipolar cells the author regards as nerve-cells, and states that the analogy between the tactile organs of lucernaria and those of the arthropoda is complete.

The digestive cavity contains a stomach, and four large radiating canals, and its walls are coated with a layer of endodermic cells, ciliated on the peristome, and single on the external walls of the body. Among these endodermic cells are unicellular glands secreting a digestive liquid. The surface of the cavity is enlarged by mesenteric filaments, one side of each filament being composed of gland-cells, the other ciliated. The author supposes the gland-cells produce a circulation in the cavity, and that the simple endodermic cells absorb the nutritive fluid. He states that the sexual elements are developed in special capsules of endodermic origin. Each capsule is composed of the endoderm, and of an elastic membrane (*membrana propria*), and is filled with ovigerous cells. A young egg has a large germinating vesicle, which disappears in proportion as it grows. The developed egg is surrounded by a strong membrane, and has a large micropyle. The ripe capsule is furnished, near its base, with a canal which serves for the exit of the sexual products. The elasticity of the *membrana propria* keeps this canal shut except when the internal pressure of the mature eggs forces it open, after which it again closes.

*The Embryogeny of the Flea.*—In a recent number of the 'Academy' there is a capital abstract of a paper lately read before the French Academy by M. Balbiani. It states that M. Balbiani finds the ovum of *Pulex felis* better adapted to researches than that of other species,



such as *canis* and *irritans*. It is more transparent, and permits the various stages of development to be better observed. As the flea's egg has been described by former observers, and especially by Leuckart, M. Balbiani merely observes concerning its envelopes, that they consist in a chorion and vitelline membrane, both very thin, transparent, and colourless. The chorion is homogeneous, without sculpture, or superficial reticulations. The rugose shell-like aspect its surface presents does not arise from this membrane, as Leuckart thought, but is caused by a coating the egg receives at the moment of its expulsion. The micropyle openings of the chorion are numerous, and are found at the anterior as well as at the posterior pole. In these two regions they are grouped in circular spaces, larger in the former, where the micropyle holes number forty-five to fifty, while in the latter there are only twenty-five to thirty. In the anterior group only has M. Balbiani seen spermatic filaments engaged. One or two days after laying, the formation of the embryo begins by a thickening of a portion of the blastoderm, in the form of a band, at first broad and diffuse, but which gradually concentrates on the ventral line of the egg. The embryonary bandelet continues to grow at its posterior part, whence it makes a fold which penetrates the vitellus, and bends round to the dorsal, or opposite, side of the egg. This replicated, or caudal, extremity of the embryo thus has for its origin a veritable invagination of the blastoderm at the posterior pole, while throughout the rest of its length the embryo results from a local transformation of the blastodermic vesicle, and consequently remains external to the vitellus. This mode of formation of the embryo of the Pulicids presents a type intermediate between that of the Dipters, in which the whole embryo is exterior, and that of the Hemipters, in which it is chiefly, and sometimes entirely, formed at the expense of a portion of the blastoderm invaginated in the vitellus. After remarking that the egg of the flea is too small to make sections to exhibit the embryonic layers, and the part they play in the process of development, M. Balbiani observes, there is no difficulty in following the development of the two membranes which have received the names of the amnios and serous envelope. With their formation, the first period of development terminates, and at this early stage of evolution, the organ of reproduction is already visible in the form of a small cluster of clear cells on the internal surface of the abdomen, immediately below the posterior margin of the vitellus. No envelope surrounds this mass of germinal cells, and the author formerly mentioned a similarly precocious appearance of reproductive elements in Aphidians and Lepidopters. The commencement of the second development period is marked by the appearance of the rudiments of cephalic appendages—antennæ and mouth-organs—which last, by progress of evolution, come to be organized as in maxillary or abrading insects (*broyeurs*). We know that the larva of the flea feeds on solid matters, while the perfect insect has a mouth adapted to suction. Another peculiarity is the appearance of the rudiments of thoracic members, though the larva is born in an apodal state. "This tendency to produce appendages like the legs of other insects, and which are destined to abort in



the embryo itself, is a very interesting fact for the partisans of the doctrine of evolution, while it is inexplicable to those who believe in the invariability of species." Among the phenomena of the third and last evolution period, M. Balbiani mentions "the rupture of the serous or external envelope of the cephalic region of the embryo, its concentration on the dorsal surface as a crumpled mass, and, finally, its penetration in the vitelline sac, or mid intestine, by an opening in the back of the embryo. At the close of this period, a little horny plate is found on the head of the larva, which enables it to split the membrane at the time of hatching. M. Künckel has described and figured this in *P. felis*, but M. Balbiani claims priority.

*The Circulation of the Blood in the Frog's Lung.*—The following mode of observing this phenomenon is thus described by Herr F. Holmgren:\*—The frog (*Rana esculenta* is the preferable species) is poisoned by several small doses of curare, so as to be paralyzed for two or three days. A broad fold of the skin is taken up near the armpit, and a curved needle, armed with a silk thread, is carried through the basis of this fold, whereupon the thread is tied. In the same manner a ligature is applied to the skin near the hind legs. Between both ligatures a sufficient portion of the skin and the thin muscular layer is removed, when the inflated lung will protrude through the wound, and soon collapse. The frog securely fastened upon a board in the well-known manner, the lung is put into a chamber which fits over the hole in the table of the microscope and is closed at both ends by glass, to allow the light to pass from the reflector through the chamber into the tube of the microscope. If now the lung is inflated again through a rubber tube, a most beautiful view of the circulation can be witnessed.

*Microscopic Examination of the Intestines in cases of Cholera.*—A valuable report which deals with the above subject has been recently presented to the public by the U.S. Government. In this Dr. Danforth, who has had to do with the microscopical portion of the inquiry, says that "under a power of about eighty diameters, the following appearances are noted: the mucous and muscular layers seemed to have been much disturbed in their relations, and separated widely apart; between them a very beautiful, loosely-woven web of areolar or connective tissue is seen sending its delicate filaments across the intervening space, with here and there a little vessel, making its way toward the mucous layer; the latter is unusually thin and unusually smooth on its free surface; not a single perfect villus can be seen, but a few 'stumps' of villi are easily made out, as though the missing portion had been rudely torn away. Under a power of 260, the surface of the mucous layer is seen to be almost, in fact quite denuded of epithelium, since not a single normal club-shaped cell can be seen. The mucous membrane seems to have passed through some scene of violence, during which its villi have been wrenched from their attachments, and its clothing of epithelium stripped from its surface and carried away. It seems almost beyond belief that a few short hours could have so totally

\* 'Centralbl. für Chir.,' No. 39.

changed the intestinal surface, but every section which I have examined from the specimen of intestine now under consideration, presents precisely the same appearances. Peyer's glands do not seem to be much altered, quite to my surprise. Possibly they are slightly swollen, but not otherwise perceptibly altered. But, after all, this is not so surprising; the storm is too brief to affect tissues beneath the surface to any great extent. It is rather like a terrible tornado desolating everything within its reach, but limited in its ravages to objects presenting salient points of attack. The submucous connective tissue and the muscular layer are both beautifully displayed, but neither present any evidence of disease, unless the unusual separation of the mucous and muscular layers be regarded as such."

*Unicellular Algae Parasitic within Fossil Corals.*—A capital paper on this subject was recently presented to the Geological Society of London, by Professor Martin Duncan, F.R.S., of which the following abstract has been given. After noticing the works of Quekett, Rose, Wedl, and Kölliker, which refer to the existence of minute parasitic borings in recent corals, recent shells, and a few fossil mollusca, the author describes the appearance presented by a great system of branching canals of about 0·003 millim. in diameter, in a *Thamnastræan* from the Lower Cainozoic of Tasmania. He then proceeds to examine the corresponding tubes in *Goniophyllum pyramidale* from the Upper Silurian formation. In sections of that coral one set of tubes runs far into the hard structure; these are straight, cylindrical, and contain the remains of vegetable matter. Neither these tubes, nor any others of the same parasite, have a proper wall: they are simply excavations, the filiform alga replacing the organic and calcareous matter abstracted. In some places the dark carbonaceous matter is absent, and the lumen of the tube is distinguishable by the ready passage of transmitted light. Other tubes run parallel to the wall, and enter by openings not larger than their common calibre. But there are others which have a larger diameter, and in which the cytoplasm appears to have collected in masses resembling conidia; and where fossilization has destroyed much of the continuity of a tube a series of dark and more or less spherical bodies may be seen. In some places, especially in the spaces between the minute curved dissepiments and tabulæ, hosts of globular spores, with or without tubes emanating from them, may be seen. In *Calceola sandalina* corresponding structures exist sometimes, and the method of entry of the parasite can be examined. The author gave two instances, one of which was seen in section. A decided flask-shaped cavity existed in the wall of the shell, opening outwards and rounded and closed inwards. It was crowded with globular spores (oospores), and these, where near the sides, had penetrated the hard shell, and thus gave a rugged and hairy appearance to the outline of the flask-shaped cavity. After noticing minute structures in a brachiopod included in a Silurian coral, and in a Lower Silurian foraminifer, the author asserted, from the results of his late researches upon the algae parasitic in corals out of his own aquarium, that the fossil and recent forms are analogous in shape, size, and distribution. He considers that the old parasite resembles *Saprolegnia ferox* in its

habit; and as he considers that *Empusina*, *Saprolegnia*, and *Achlya*—members of the Protista—are the same organisms, living under different physical conditions, he names the old form *Palæachlya penetrans*; and he believes that it entered the wall by the spores fixing on to the organic matter, and growing by its assimilation, and that carbonic anhydride was evolved. He considers that this acid, assisted by the force of growth and the movement of the cytoplasm, are sufficient to account for the presence of the tubes. Finally, the author draws attention to the probable similarity of external conditions in the Silurian and present times, and to the wonderful persistence of form of this low member of the Protista.

*Dr. Woodward on the Spurious Lines of Diatoms.*—The 'American Naturalist,' in its January number (which is the first of a new series, and is really an admirable number), states, that at the Philosophical Society of Washington recently Dr. Woodward, of the Army Medical Museum, gave an account, illustrated by photographs and illuminated photographic pictures thrown upon a screen, of spurious lines, noticed by Dippel, and more lately in a British periodical, as genuine, seen on certain diatoms. The species *Frustulia Saxonica* has transverse lines of extreme fineness, and longitudinal lines had been described by Dippel and others, some asserting that the latter were coarser, and others that they were finer than the transverse ones. Dr. Woodward showed very clearly by his illuminated slides, enlarged on the screen 45,000 diameters, that the longitudinal lines appeared not only on the diatom, but also on the space external to it, and similar lines appeared about specks of dirt on the plate. These could be varied in coarseness by different illuminations of the object. Hence he concluded that they were spurious, and caused by diffraction of light from the midriff, or the edge of the diatom, or any other object in the field. He remarked that the existence of real lines could be determined by the fact that they did not vary in number under varying illuminations or focussing; they were either seen uniformly or not seen at all.

*Relations between Plants and Animals.*—This subject has been recently lectured on by Prof. Huxley at the Royal Institution. A full report of the Professor's remarks will be found in 'Macmillan's Magazine' for February. After describing very fully some remarkable monads which were found in an infusion made by Prof. Tyndall, and referring in most complimentary terms to the papers published in this Journal by Mr. Dallinger and Dr. Drysdale, the Professor concluded by observing that keen and patient research induces the belief that such an insensible series of gradations leads to the monad that it is impossible to say at any stage of the progress—Here the line between the animal and the plant must be drawn. It is therefore a fair and probable speculation, though only a speculation, that as there are some plants which can manufacture protein out of such apparently intractable matters as carbonic acid, water, nitrate of ammonia, and metallic salts, while others need to be supplied with their carbon and nitrogen in the somewhat less raw form of tartrate of ammonia and allied compounds, so there may be yet others, as is possibly the

case with the true parasitic plants, which can only manage to put together materials still better prepared, still more nearly approximating to protein, until such organisms are arrived at which are as much animal as vegetable in structure, but are animal in their dependence on other organisms for their food. The singular circumstance observed by Meyer, that the torula of yeast, though an indubitable plant, still flourishes most vigorously when supplied with the complex nitrogenous substance, pepsin; the probability that the potato disease is nourished directly by the protoplasm of the potato plant; and the wonderful facts which have recently been brought to light respecting insectivorous plants, all favour this view; and tend to the conclusion that the difference between animal and plant is one of degree rather than of kind, and that the problem, whether in a given case an organism is an animal or a plant, may be essentially insoluble.

*Prickle-cells in the Wall of the Stomach of certain Animals.*—In 1864 M. Schultze discovered the so-called "prickle-cells" in the mucous membrane of the mouth and conjunctiva, and in the rete Malpighi. A few years later these peculiar cells were found by F. E. Schultze, in the epithelial covering of the lip, of the tongue of the sturgeon, in the skin of *Triton niger*, *Rana esculenta*, &c. Now, according to the 'Medical Record,' Joh. Brümmer\* has found these cells in the first or muscle-stomach, and in the cesophagus of the dolphin, in the stomach of the ox, in the left part of the stomach of the horse, in the stomach of the common rat, house-mouse, water-rat, and field-mouse. The author is of opinion that these cells occur wherever the epithelium of the stomach is hard and like horn, and their formation is proportional to the extent of the corneous process. They seem by their firm attachment to form a firm tough epithelium which serves in one place for protection—e. g. in the skin; in another for breaking up the food—e. g. in the wall of the stomach.

*The Seeds of Collomia coccinea.*—A writer, who signs himself P. J. C., writes as follows to 'Hardwicke's Science Gossip' (February 1876):—"I have received from a friend a few of these very interesting seeds; he gave me these directions to obtain a most curious sight: 'Having obtained your seeds, take a sharp pocket-knife, and cut off as small a quantity as possible of the outer skin, then place it upon your fluid slide, and cover it with a small square glass slip; at first use your 1-inch object-glass, and it looks like a small piece of dirt, but directly you put the smallest quantity of water in at the top of the slip, so as to touch the seed, myriads of spiracles will start away from it, and continue so to do for nearly ten minutes. I have tried this experiment a great many times, and always with success.'"

*The Production of the Prothallus from the Spore of the Chara.*—Herr A. De Bary has published a recent paper on this subject in the 'Botanische Zeitung,' in which he gives a detailed account of the manner in which the prothallus is produced from the spore in the Charæ. That the new Chara-plant does not spring directly from

\* 'Centralblatt,' No. 28, 1875.

the spore was first shown by Pringsheim, who noticed that the plant is a lateral outgrowth from an intermediary filamentous structure, the *vorkeim* (prothallus). De Bary finds that a lenticular portion of the spore projects beyond the mass of the spore, from which it is soon separated by a wall. The lenticular portion is then divided into portions, one of which develops into the prothallus proper, while the other becomes what is known as the primary root in *Chara*, although it does not correspond to the structure of the same name in phanerogams. In passing, reference is made to parthenogenesis in *Chara crinita*, which fact is confirmed by De Bary, who finds that female plants isolated in closed glass vessels fruit abundantly.

*Egg and Bud Development of Salpa spinosa.*—It appears from the January number of the 'American Naturalist' that Mr. W. K. Brooks recently read a paper before the Boston Natural History Society on the egg and bud development of *Salpa spinosa* (Otto). The life history of *Salpa* may be stated in outline as follows: the solitary *Salpa* is the female, which produces a chain of males by budding, discharging an egg into each before birth. These eggs are impregnated while the zooids of the chain are small and sexually immature, and develop into females, which give rise to other males by budding. After the embryo has been discharged from the body of the male, the latter grows up, becomes sexually mature, and discharges its seminal fluid into the water, by means of which it is carried to the eggs within the bodies of younger chains.

*The Primordial Utricle.*—Herr Professor Pfeffer has lately studied the so-called primordial utricle, with the following results, which are given in the 'Botanische Zeitung,' October 1, from 'Kölnische Zeitung,' 1875, 248. Protoplasm placed in contact with aqueous solutions becomes clothed on all sides with a delicate membrane caused by precipitation. This is the so-called primordial utricle. In protoplasm, certain albuminoids are dissolved, which separate out in water because their solvent is withdrawn. But this is limited to the surface of contact, because the membrane formed by precipitation does not allow the solvent to pass through. What this solvent is, has not been ascertained positively, but it is believed to be something besides the inorganic salts which, in egg-albumen, hold a protein substance in solution.

*The Tyndall and Bastian Controversy.*—To attempt to give an abstract of this is well-nigh as feasible as draining Niagara with a teaspoon. But we shall make the effort; at the same time we may state that our readers will find all the information that has been published since Dr. Tyndall's lecture was delivered, in the 'British Medical Journal,' Jan. 29, Feb. 5 and 12; 'Nature,' Feb. 10 and 17; the 'Lancet,' Feb. 5 and 12. Dr. Tyndall's lecture contained many points of interest, but one passage from it will give the substance of his conclusions. After describing at some length the form of box which he had selected for his experiment, he says:—"On Sept. 10 the first case of this kind was closed. The passage of a concentrated beam across it through its two side windows then showed the air

within it to be laden with floating matter. On the 13th it was again examined. Before the beam entered, and after it quitted the case, its track was vivid in the air, but within the case it vanished. Three days of quiet sufficed to cause all the floating matter to be deposited on the sides and bottom, where it was retained by a coating of glycerine, with which the interior surface of the case had been purposely varnished. The test-tubes were then filled through the pipette, boiled for five minutes in a bath of brine or oil, and abandoned to the action of the moteless air. During ebullition aqueous vapour rose from the liquid into the chamber, where it was for the most part condensed, the uncondensed portion escaping, at a low temperature, through the bent tubes at the top. Before the brine was removed little stoppers of cotton-wool were inserted in the bent tubes, lest the entrance of the air into the cooling chamber should at first be forcible enough to carry motes along with it. As soon, however, as the ambient temperature was assumed by the air within the case, the cotton-wool stoppers were removed. We have here the oxygen, nitrogen, carbonic acid, ammonia, aqueous vapour, and all the other gaseous matters which mingle more or less with the air of a great city. We have them, moreover, 'untortured' by calcination and unchanged even by filtration or manipulation of any kind. The question now before us is, Can air thus retaining all its gaseous mixtures, but self-cleansed from mechanically suspended matter, produce putrefaction? To this question both the animal and vegetable worlds return a decided negative. Among vegetable experiments have been made with hay, turnips, tea, coffee, hops, repeated in various ways with both acid and alkaline infusions. Among animal substances are to be mentioned many experiments with urine; while beef, mutton, hare, rabbit, kidney, liver, fowl, pheasant, grouse, haddock, sole, salmon, cod, turbot, mullet, herring, whiting, eel, oyster, have been all subjected to experiment. The result is that infusions of these substances exposed to the common air of the Royal Institution laboratory, maintained at a temperature of from 60° to 70° Fahr., all fell into putrefaction in the course of from two to four days. No matter where the infusions were placed, they were infallibly smitten. The number of the tubes containing the infusions was multiplied till it reached six hundred, but not one of them escaped infection. In no single instance, on the other hand, did the air, which had been proved moteless by the searching beam, show itself to possess the least power of producing Bacterial life or the associated phenomena of putrefaction. The power of developing such life in atmospheric air, and the power of scattering light, are thus proved to be indissolubly united."

Now to this lecture Dr. Bastian published a very intemperate reply, couched in language entirely unbecoming a follower of truth alone.\* In this he cites at length the names of a series of authors who agree with him, among whom we find those of *Schwann* and *Pasteur*. He alleges that Professor Tyndall used infusions which were not strong enough, and that he did not boil them long

\* 'Brit. Med. Journal,' Feb. 5.



enough (!). He also cites an experiment performed by Dr. Burdon Sanderson, which, according to Dr. Bastian, is proof of the development of bacteria, not from pre-existing germs, but by spontaneous generation. However, Professor Sanderson recognizes the fact that they may have been developed from bacteria germs which maintained a power of resisting the influence of the boiling.

Now, in answer to these arguments of Dr. Bastian, Dr. Tyndall firstly shows that the very first of Dr. Bastian's asserted supporters—Schwann—is a direct opponent, and that it was because Dr. Bastian neglected to read the whole of his remarks that he came to his false conclusions. Schwann's statement, as Dr. Tyndall shows, is directly opposed to Dr. Bastian; for in Poggendorff's 'Annalen'\* he writes: "At the last meeting of naturalists in Jena, I communicated experiments on spontaneous generation, by which it was proved that, when a closed glass globe containing a small quantity of an infusion of muscle, and filled with air, is exposed to the temperature of boiling water, so that both the liquid and the air are heated to 80° Réaumur, then, even after a period of several months, no infusoria are generated, and no putrefaction occurs."

In regard to the second point, the adhesion of M. Pasteur to Dr. Bastian's arguments, we may give the following quotation from a letter by M. Pasteur, published in 'Nature' (Feb. 17), which shows clearly enough, if it was not stated so in the beginning of the letter, that he is a decided opponent of spontaneous generation:—"Le docteur Bastian me permettra de placer dans sa bouche ces paroles: 'C'est bien vrai, les expériences de M. Pasteur et celles de M. Tyndall m'ont aculé, moi Docteur Bastian, partisan de la génération spontanée, dans cette déclaration. Oui, je préfère recourir sans motif sérieux, à la croyance à une force résidant dans la partie amorphe des poussières en suspension dans l'air, plutôt que de la placer cette force dans la partie organisée formée de corpuscules identiques d'aspect à ceux des germes des organismes des infusions.' Parler ainsi n'est-ce pas avouer sa défaite?"

The most temperate letter which has been written on this subject is that which appeared in 'Nature' (Feb. 10), signed "Inquirer." In this the writer points to the difference between the results obtained by Dr. Tyndall and Dr. B. Sanderson (differences which are more apparent than real as regards the conclusion to which both lead), and asks Professor Tyndall to explain the apparent contradiction. To this letter Professor Tyndall replies by pointing out that he will leave the repetition of such experiments to Dr. Sanderson himself, "with the full confidence that the ability and candour for which he is so distinguished will lead him to a right result." At the same time he most fairly invites "Inquirer" to see his infusions, and observes that "it will give me great pleasure to show them to him."

There is one other point in reference to this controversy, it is that Professor Wanklyn states† that Professor Tyndall "has forgotten that the resistance of the atmosphere retards the gravitation of infinitesimally small particles, and that particles too small for the highest

\* Vol. xli., 1837.

† 'Brit. Med. Journal,' Feb. 12.



microscopic power would not sink to the bottom of his boxes in three days, and perhaps not even in three years. Furthermore the boxes are not at all air-tight, as everyone who has studied Pettenkofer's classical researches will know, and Dr. Tyndall's boxes are simply wooden filters." But as he further admits that the boxes will at least act as powerfully as cotton-wool in excluding particles, there is of course nothing more to be said.

Our conclusion cannot be drawn yet, as both sides are preparing further experiments. But we think that Professor Tyndall has thrown much light on the subject, and unquestionably he has come out of the controversy with all the weight of scientific evidence and philosophic gravity of discussion on his side, while Dr. Bastian has done injury to his cause by adopting the well-known symptom of defeat, "abuse of the plaintiff's attorney."

*The Evolution of Hæmoglobin.*—Mr. Sorby, F.R.S., in a letter to 'Nature' (Feb. 17) states that the principal results of his recently published paper\* are contrary to what 'Nature' stated, that hæmatin is first met with in the bile of many pulmoniferous molluscs in an abnormal state, quite unfit to serve the purposes of respiration, but easily changed into the normal, which could, and probably does in some cases, perform that function. Then in the blood of Planorbis we have a *solution* of a hæmoglobin, in which the hæmatin is combined with an albuminous constituent coagulating at the low temperature of 45° C., and finally we come to the normal hæmoglobin existing as *red corpuscles*, containing an entirely different albuminous constituent, coagulated at about 65° C. In all these changes in the condition of the same fundamental radical, the oxygen carrier becomes of more and more unstable character, and more fitted for the purposes of respiration, as we advance from lower to higher types, as though advantage had been taken of every improvement due to modified chemical or physical constitution.

*Action of certain Colouring Matters on the Tissues.*—It seems that this subject has been recently investigated by Herr L. Gerlach, of Erlangen, an abstract of whose paper is given by the 'Medical Record' (Jan. 15). It states that Herr Gerlach adopted the method of saturating the tissues with this substance for days and even weeks together; the former experimenters, Heidenhain, Kupfer, Von Wittich, and Thoma, only injected such a quantity of indigo carmine as remained in the body for a comparatively short time. The author injected indigo carmine into the lymph-sac of several frogs, and killed them at intervals of two days, always renewing the injections. The microscopic examination showed that the white blood-corpuscles are capable of taking up indigo carmine.

1. The first traces of this action appear on the third day after the introduction of the colouring matter. After this time, both the number of cells which contain the pigment and the quantity of pigment in the individual cells increase.

2. The cells of the connective tissue, e.g. of the tendons, take

\* 'Quarterly Journal of Microscopical Science.'

up the colouring matter. This is to be observed from the fourth day.

3. No indigo pigment is deposited in the bone-cells.

4. The pigment is found in the cartilaginous tissue, e.g. the articular cartilage of the hip-joint, from the fifth day onwards. None is found in the ground-substance or matrix.

5. The nerve-cells never contain the indigo; only in a few cases was it found in the sympathetic ganglion-cells between the cell-contents and the sheath.

6. The blue coloration of the epithelial cement pointed out by Thoma and Küttner is also true for that of the so-called endothelium.

## NOTES AND MEMORANDA.

**Mounting Ostracoda in a Permanent Manner.**—Mr. E. Gardner gives the following mode, in the January number of the 'Journal of the Quekett Club.' He says:—"I have been trying for a long time to mount the Ostracoda and allied genera in a permanent manner, and having at last fancied that I have succeeded, as my slides show no alteration after some months, I beg to communicate my method, in the hope that other young microscopists will improve upon it, and give the results of their experience. I found that fluid media were of no use, as endosmose, sooner or later, destroyed the objects, which do not admit of being dried for mounting in resinous media. I therefore tried a mixture of two-thirds gum arabic and one-third syrup, made with loaf-sugar with a few drops of alcohol and creosote, and a little corrosive sublimate. I found that a drop of this mixture hardened sufficiently in about two days to imbed and preserve the object, and to admit of the cell being filled up with gum dammar in benzole. I use that prepared by White, of Litcham, in collapsible tubes. Should the object show above, or project through the first coat of gum when hardened, more must be dropped in, until it is quite imbedded. The object is then covered with thin glass. My reason for mixing the syrup with the gum arabic is merely to prevent the gum from cracking or contracting too much when dry."

**Officers of the American Microscopical Society.**—We are requested to state that at the annual meeting of the American Microscopical Society of the City of New York, held Tuesday evening, January 25, 1876, the following officers were elected for the ensuing year:—President, John B. Rich, M.D.; Vice-President, Wm. H. Atkinson, M.D.; Secretary, C. F. Cox; Treasurer, T. d'Orémieulx; Curator, O. G. Mason.

**An American Adjustable Concentric Stage for the Microscope.**—We have received a letter from Mr. W. H. Bullock, a microscope-maker of Chicago, U.S.A., in which he asserts that "the exhibition of Mr. Crouch of the microscope with adjustable concentric stage, at the

December meeting of the Royal Microscopical Society, is considerably behind the times. I exhibited a stand with the same attachment before the Illinois Microscopical Society in December, 1870. It had three milled screws, so that it was not necessary to use a screw-driver. Dr. H. A. Johnson, of this city, has a stand that is central with  $\frac{1}{2}$ "th objective, and there is not a so-called concentric rotating stand of English make that I have seen in this country that is central with  $\frac{3}{8}$ ." Mr. Bullock has sent us an illustrated description, which certainly bears out some of his ideas.

**A Concentrated Mode of Mounting.**—The 'American Naturalist' states that Mr. C. H. Robinson, of Cleveland, contributes to the "Postal Micro-cabinet Club" a slide illustrating a method of mounting where the space under a single large cover-glass is occupied by a considerable number of small circles with an object in each. He makes the circles of white zinc varnish, and sometimes adds a circle to the edge of the cover-glass as a finish. This method of mounting, the appearance of which is decidedly handsome, is particularly applicable to displaying several varieties of one species (as of selected diatoms or of Foraminifera) on one slide, or to presenting in contrast different methods of preparing the same species.

---

## CORRESPONDENCE.

---

### ON THE IMMERSSED APERTURE QUESTION.

*To the Editor of the 'Monthly Microscopical Journal.'*

SIR,—I can by no means acquiesce in the statement made by Mr. Mayall in the last Journal. I will make a brief remark only on the first paragraph.

The adjustment seems to be a stumbling-block for those advocating an extra immersion theory. We have now in use thousands of serviceable immersion object-glasses capable of defining most tests, and which have no adjustment, as they are set for an average thickness of cover. They answer well, because in the *immersion* system the errors of cover-aberrations are nearly eliminated, and with a balsam intermedium they would be inappreciable. The apertures of these lenses are, I presume, taken by the usual sector method. Place a slide with object in focus mounted dry with fluid intermedium, and measure the aperture through the glass slip. Take another with an object in balsam and again measure the aperture the same way. The measurements will be similar. The balsam has given no increase. It was known when most of us were children that a close position of the lenses gave increase of aperture, but I cannot allow that this is attributable to any immersion principle. I have before given this answer.

Mr. Mayall in describing the "demonstration" overlooks, and makes no mention of certain facts that were shown, of vital importance to the truth of my statements regarding the Tolles'  $\frac{1}{4}$ th. When Mr. Mayall unexpectedly brought this objective, I could not at the time call to mind all the particulars of trials made two years ago, and needed reference to my notes. However, I told him that the slit in the semi-cylinder was formed by placing two strips of tinfoil across the centre, with their edges approximating, having been set in position under a low power by the aid of Canada balsam. I presented Mr. Mayall with a semi-cylinder better polished and finished; he brought the original one, having put a slit in place, and asked about the width. I said that it was far too wide, and so it proved, as it gave about the same immersion apertures stated by Mr. Tolles. I then made a slit narrower and with a water contact and proper adjustment; the result was an immersion aperture—less than the  $68^\circ$  I had formerly given. Mr. Mayall then protested that the thickness of the foil perhaps cut off oblique rays. Thinking that there might be some reason in this (though I did not ascertain if it was so by light coming through at over  $100^\circ$ ), the remedy at once occurred to me. I covered the plane of the semi-cylinder with opaque black varnish, through which with a steel point I made a fine clean cut exactly midway across the semi-cylinder. The test now repeated with water again gave an angle of less than  $68^\circ$ ! Mr. Mayall then strongly contested that the slit was "too narrow." I replied that it would bear to be made wider and still bring the angle within  $82^\circ$ . I wished to do this, but it was not tried, nor can I tell the actual width of the slit as the varnish was immediately wiped off, and thus the "demonstration" ended, Mr. Mayall only allowing such a width of slit as would support his statements, and bring the aperture up to near what Mr. Tolles had asserted, and I adopting a slit that would cut off lateral pencils and show the aperture I had formerly stated! As we could not agree upon this point, I concluded that it was useless to call Mr. Mayall's notice to any other measurements to prove my position.

From recent experiments I maintain that the narrower the slit, the more accurate the results; I mean, of course, a slit with thin edges, that will not cut off rays within the aperture to be tested. It is obvious that the slit may be opened so wide as to be practically without effect. I leave it to even the most inexperienced to judge which direction is most conducive to accuracy, for the object of the slit is to obtain a mere line, or film of light in the focus of the object-glass.

The  $\frac{1}{4}$ th object-glass being out of my possession, I was unable to make any further verifications free from impediment. I therefore requested Mr. Crisp to again favour me with the loan of it, and with his usual courtesy and impartiality he has done so. I now repeat the measurements with a semi-cylinder having in its centre a clear line cut through black varnish, and a thin glass cover cemented over the slit with Canada balsam. On looking through the slit it admitted rays through beyond an angle of  $130$ , the object-glass was focussed to slit and carefully adjusted for best definition, and though

now exactly under the conditions of an object mounted in balsam, and thus somewhat differing from my trial of two years ago, yet the aperture came out *the same*, viz.  $68^\circ$ .

Next the polished surface of front lens was again measured by micrometer; it was found, as before,  $\cdot 043$  inch. The distance of the immersion focus on an object in Canada balsam was now carefully ascertained; the object-glass being properly adjusted for aberration, it was found to be  $\cdot 025$  inch; taking the front lens for a base line, with this height the angle is  $81\frac{1}{2}^\circ$ , showing that an immersion angle of  $98^\circ$  is *simply impossible*. But the utilized portion of the front lens, through which all the rays or aperture emerge or enter, is much within the diameter; the spot can be ascertained with the greatest precision. With the lenses closed so as to give the largest area, the working diameter through which the rays passed was found to be only  $\cdot 033$  inch.

Mr. Mayall says that he is "compelled to take my utterances in the 'M. M. J.' as representing the views I hold." I believe he has no alternative. I am conscious of some omissions and obscurities in description, but had I described everything that I have tried, this already excessively tedious controversy would have become quite intolerable. At page 117 of this Journal for March, 1874, in explaining the use of the semi-cylinder, I say, "And the focal front (meaning point) of object-glass *a*, Fig. 4, brought to the centre of the semi-cylinder *c*, at which there is a *thin metal slit* or stop of suitable diameter." Then follows this sentence: "In this measurement I have rather over than under estimated the aperture from using a stop too large; less than  $\frac{1}{30}$ th of an inch would have been more proper." There is certainly a mistake here, carelessly written. This misplaced sentence might have been left out, as the main strength of Mr. Mayall's argument is based upon it. I told him positively, and now repeat, that in the conical front cap with the  $\frac{1}{30}$  inch front opening I never used either water or balsam, and that all the immersions were tried with a *slit*, as I had a lively recollection of the trouble of adjusting slits of different widths tacked on with Canada balsam, and set parallel in place under a low power.

The conical aperture of  $\frac{1}{30}$  inch was adopted merely as one means of showing that in the  $\frac{1}{3}$ th the preposterous aperture of  $180^\circ$  did not exist. *I had not then discovered the slit*. The idea of this, and its adoption, was suggested by the *conical aperture*.

I am very glad that Mr. Mayall, after the publication of such a statement, suggests a trial before competent judges. I accept the challenge with much pleasure, and hope he will form an unprejudiced committee who will not, at all events, wade back through all the length of this miserable controversy to seek only for dubious sentences or anomalies of description. The simple facts before them would be, Does this glass give an immersion angle beyond  $82^\circ$ , or does it not? on the items of the immersed aperture taken with the slit and the semi-cylinder, and also on the measurement of the diameter of the front lens, and the length of the corrected immersion focus, on an object in Canada balsam. The last alone will suffice to show that the

immersion aperture claimed by Mr. Tolles is utterly impossible in this case.

Many regret the reappearance of this miserable controversy concerning Mr. Tolles'  $\frac{1}{4}$ th, occupying as it has done over two years in time; but, like an ill-healed sore, it breaks out again. My experiments and discoveries relating to the microscope have been made for the love of the science, they have been fully explained and freely given at my own cost without a thought of pecuniary interest. Can some of my opponents declare the same? Confessedly having a purpose, they never tire of bringing the name prominently forward. I cannot blame the motive, although it is a quaint method of advertising.\* But let me express my belief that Col. Woodward and Professor Keith are far above this, and I do not doubt for a moment that they have discussed the question with strict integrity in accordance with the purport of their ideas concerning the optics of the microscope, and if I have not shown that deference for their opinions that some would fain exact,† it is not for want of respect; but having carried on experimental and practical inquiries on these subjects more or less for twenty-five years, I consider that the experience that I have gained entitles me to an opinion and some authority in these questions.

And what does all this wearisome controversy, with its bickerings and misquotations, tend to? Merely a desire to show that I deny that a greater angle than  $82^\circ$  can be obtained with the immersion lens on a balsam-mounted object. I do not make any such contradiction; my assertion is, that not only Mr. Tolles' object-glasses, but all others that I have yet seen, do not give near an angle of  $82^\circ$  in balsam.

I myself claim to be the first that suggested and made a practical combination or doublet front that would give undiminished angles thus mounted. The principle was described by me in the 'Quarterly Journal of Microscopical Science,' No. xii., July, 1855. Had this been suggested by *anyone else*, it would have been eagerly quoted against me in controversy, to show that angles beyond  $82^\circ$  could be got in balsam. This was a special adaptation for that very purpose; I have referred to it several times in evidence of my position, and called Mr. Mayall's attention to it particularly, but it is simply ignored. I here reproduce the diagram. The lens (nearly a hemisphere) is connected by Canada balsam to the covering glass of a balsam-mounted object situated in the centre at *a*. "It will be seen

\* "His (Mr. Wenham's) recent papers have drawn the attention of microscopists throughout Europe and America to the work of a brother optician, more effectually than anything else could have done, and have exhibited more conclusively the difficulties overcome, and illustrated more strongly the skill manifested in so overcoming them, than anything the other would have ventured to say for himself."—Charles Stodder, 'M. M. J.,' Feb. 1, 1874.

† "And now feel under great obligations to him for originating the discussion or controversy, which has done so much to bring into notice, both in America and Europe, the merits of American workmanship."—*Ibid.*, Dec. 1, 1875.

† "While the other (Mr. Tolles), not content with having the *splendid testimony* of Dr. Woodward and Professor Keith in his favour, must needs venture to speak in his own behalf, with almost disastrous effect to his own lucidity."—J. Mayall, 'M. M. J.,' Aug. 1875, page 93.



from the position of the object, that each ray of light passing from that point through the surface of the hemisphere will be transmitted in straight lines in a radial direction without undergoing any refraction; the consequence of this is that the full and undiminished aperture of the object-glass is made to bear upon the object."

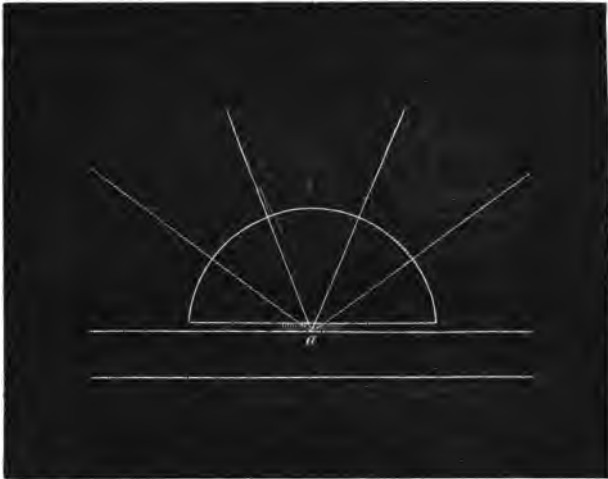

In this there is no need of abstruse calculations, or diagrams from high mathematical authorities; for such if they do not correspond with actual results only tend to confusion, for by this diagram it can be seen at a glance that *any* aperture existing in the back combination is directly transmitted to the object in balsam without loss from refraction. If the radius of the immersion front is lengthened or falls beyond the object, then the angle of the back combination being refracted by a flatter surface, will become diminished.

As it may be argued that this only suggests a principle and is not a practicable object-glass, inasmuch as the front lens even though set in place was not attached to the cell as part of the system, I have therefore just finished a cell-adaptor with a front lens of this description, applied to a combined immersion and dry  $\frac{1}{4}$ th of fine quality, and the result confirms the high opinion that I formed of it when the idea first occurred to me.\* When used as an ordinary water immersion object-glass, I have yet seen nothing that equals it on tests in balsam. It also acts perfectly as an immersion on objects mounted dry; and,

\* "When an object is seen under these circumstances, it at once shows the great increase of distinctness that is to be obtained in the structure of the more difficult diatomaceous tests when they are thus viewed in Canada balsam, with the full aperture of the object-glass: markings which in the neighbouring *dry* objects of the same character are scarcely discernible, are sharply and distinctly visible under the hemisphere with the same illumination."—'Quarterly Journal of Microscopical Science,' July 1855, No. xii., p. 304.



further, it is still quite achromatic, and performs as a dry or non-immersion objective in a highly satisfactory manner—of course, with suitable adjustment in each case.\*

I am, Sir, yours obediently,

www.libtool.com.cn

F. H. WENHAM.

ARE THE GLANDULAR BODIES DESCRIBED BY PROFESSOR BENNETT  
REALLY BENEATH THE CUTICLE?

To the Editor of the 'Monthly Microscopical Journal.'

OATLANDS VILLA, HARROGATE, January 12, 1876.

DEAR SIR,—I am ignorant of your regulations respecting the papers published in the 'M. M. J.,' but, if it be allowed, I should like to make a few remarks on a portion of Mr. Bennett's paper in the January number, with a view to their publication in the next.

It is there stated that on the leaves of *Callitriche verna* there are a number of glandular bodies, similar in many respects to those found on the leaves of *Drosera* and *Pinguicula*. They are said to be "nearly spherical, and distinctly quadripartite, each division being again filled with a yellowish-brown substance," and to be "entirely concealed beneath the surface,"—that is "beneath the cuticle."

Now I have often had these bodies under observation, and from what I have seen I am quite convinced that they are above the surface of the leaves, and are indeed epidermal structures. They are found not only on the leaves, both floating and submerged, but also on the stem. Many of them are "distinctly quadripartite," but others are as commonly met with in which the number of cells is larger—seven and eight-celled ones being especially frequent. In none of them do I discover any "yellowish-brown substance," even with a  $\frac{1}{4}$ th and  $\frac{1}{8}$ th Hartnack. Their contents have the appearance of ordinary protoplasm, though some of them seem empty. By *focussing downwards*, an inner and smaller circle becomes visible, which I take to be the line of union with the epidermis; and my observations seem to show that in some instances the cells separate at the apex, so as to form an opening into the interior, similar to that seen at the summit of the arche-gonia on the *prothallia* of Ferns.

\* It is due to Col. Woodward to state that I have received a most friendly letter from him disavowing all sympathy with the personalities of some who have written in this controversy, in a non-scientific spirit. I have more than once acknowledged that Mr. Tolles (though his interest lay in the construction of object-glasses) has maintained his good humour, and I believe has argued the point with an indefinite idea that he is right. I do not read the American journals, and anything appearing in them concerning myself must remain unanswered. A recent one has been sent to me by a friend, which contains an anonymous letter "from an eminent (so termed) microscopist of England who has written much on the subject to a friend in this country" (America). The person so sheltered to effect a stab in the dark, displays towards myself a petty malignity quite unparalleled, which I trust everyone else has been free from.

My reasons for regarding these bodies as epidermal appendages are:—1. They certainly appear naked and uncovered by any epidermal membrane, the focus for the epidermis being lower than that for the glands, but agreeing with that for the small inner circle referred to. 2. A favourable preparation will sometimes show them projecting over the edge of the section, and provided with a short peduncle. 3. On several occasions I have dissected out the growing point of a young bud, on which were leaves in different stages of development. On these I find a few projecting unicellular bodies, whose protoplasm was distinctly vacuolated, in a manner that seemed to foreshadow the subsequent division into two, four, or more cells.

If these observations are correct—and, having repeated them so often, I have no doubt that they are—it appears to me that Mr. Bennett's statements will require to be modified.

I may add further, that if the bodies under notice have any physiological relations with the glands of "insectivorous plants," with which they are compared, analogy would lead us to expect them *on*, rather than *beneath* the epidermis, as is the case with those of *Drosera*, *Dionæa*, *Pinguicula*, &c.

I am, Sir, yours most respectfully,

THOS. HICK, B.A., B.Sc.

## PROCEEDINGS OF SOCIETIES.

### ROYAL MICROSCOPICAL SOCIETY.

KING'S COLLEGE, February 2, 1876.

Anniversary Meeting.—H. C. Sorby, F.R.S., President, in the chair.

The minutes of the preceding meeting were read and confirmed.

A list of donations to the Society was read by the Secretary, and the thanks of the meeting were voted to the donors.

The Treasurer read his Annual Statement of the accounts of the Society for the past year, duly audited and found correct.

The President having put the motion from the chair, "That the report of the Treasurer be received and adopted," declared it to be unanimously carried.

The Secretary read the Annual Report of the Council, which was in like manner received and adopted by the meeting.

The Secretary said he had an announcement to make, which he felt sure would be received by the Fellows with great gratification. They had received from the President a very kind and handsome offer to give a soirée to the Fellows of the Society on the evening of Friday, the 21st of April. He thought this a very handsome offer on the part of the President, who had undertaken to defray the entire expense of

the entertainment (which they knew the Society itself could not afford to do), and he might add that the authorities of King's College had granted the use of the building for that occasion. He felt sure that all present would show their appreciation of this offer by expressing their hearty thanks to the President for his kindness. He wished also to remark that it was most desirable that as large a number of objects as possible should be exhibited by Fellows of the Society on that occasion. They would perhaps remember that at the old soirées of the Society they were chiefly indebted to the makers, but it was hoped they would personally exert themselves on the next occasion. The evening was that of the Friday in Easter week.

The cordial thanks of the meeting to the President for his liberal offer were then unanimously voted by acclamation.

Mr. Jas. Glaisher, F.R.S., said it gave him great pleasure to have the opportunity of moving the hearty thanks of the Society to the President and Officers of the Society for their services rendered to it during the past year. As an old officer of the Society, and one who had been intimately connected with its working in former times, as one who knew so well the qualifications of the gentleman who now presided over it, and as one who had so long known and worked with its honoured Secretary (Mr. Slack) and the genial gentleman to his right (Mr. C. Stewart), he felt that there was no better person in the room to make this motion than himself. When they considered the result of the Treasurer's report, and the position in which it showed the Society to be, that alone told them how faithful these gentlemen had been to the trust reposed in them, and it was only those who had similarly acted who could tell how much time and attention and care had been given for the Society's advantage. But it had been a painful thing to him to see in the Journal which contained their Proceedings the kind of correspondence which had lately appeared there, and of which he thought they might justly feel ashamed. In all parts of the country he had been spoken to about it, and it filled him with regret and pain that this should be the case. Were they not all searchers after truth? Were they not all fellow-workers for the same ends? And could they not, therefore, carry on their correspondence in a friendly and kindly way? Let him go where he would—to the British Association, or Royal Society, or elsewhere—this matter was spoken of to him with surprise and regret, and he would urge upon them as a Society that they should by any means, at any cost, keep from that Journal that bore their name every letter that showed the spirit which he had so deeply deplored. He would further only call to mind the many hours which the Council devoted to the Society's interests when he asked that their services might be remembered, and that the best and warmest thanks of the Fellows should be to their President, to their Secretaries, and to the Council generally for their conduct of the Society's affairs during the past year.

Mr. B. D. Jackson seconded the motion.

Mr. Glaisher having put it to the meeting, and declared it to be unanimously carried, expressed the great pleasure which he had

in presenting the cordial and unanimous thanks of the Society to the President and Council, and in offering his best wishes to them for the future.

The President said he had great pleasure in expressing on behalf of the Officers and Council, as well as for himself, their thanks to the Fellows for the kind way in which this vote of thanks had been received. He could only say that they were always happy to do all they could for the Society, and only wished that they could do more.

Mr. Suffolk and Mr. Palmer having been appointed scrutineers, proceeded to the ballot of Officers and Council for the ensuing year, and having handed in the result, the following gentlemen were declared by the President to be duly elected:

As *President*.—H. C. Sorby, Esq., F.R.S.

As *Vice-Presidents*.—Chas. Brooke, M.A., F.R.S.; W. B. Carpenter, M.D., F.R.S.; Rev. W. H. Dallinger; Hugh Powell, Esq.

As *Treasurer*.—J. W. Stephenson, F.R.A.S.

As *Secretaries*.—H. J. Slack, F.G.S.; Chas. Stewart, M.R.C.S., F.L.S.

As *Council*.—\*Robert Braithwaite, M.D., F.L.S.; Frank Crisp, LL.B., B.A.; John E. Ingpen, Esq.; \*Emanuel Wilkins Jones, F.R.A.S.; William T. Loy, Esq.; Henry Lawson, M.D.; \*John Millar, L.R.C.P.E., F.L.S.; \*John Rigden Mummery, F.L.S.; John Matthews, M.D.; Frederic H. Ward, M.R.C.S.; Francis H. Wenham, C.E.; Charles F. White, Esq.

The President then delivered the Annual Address to the Society, the subject of which was the probable limit of the powers of the microscope consequent upon the properties of light, considered with reference to the ultimate constitution of matter. The Address, which was of considerable length and deep interest, was listened to with close attention, the speaker being loudly applauded at its conclusion. (The Address is printed at p. 105.)

Mr. Charles Brooke felt sure that all present must have listened with great interest to the very extraordinary speculations which the President had brought under their notice. Many of them were speculations upon speculations, so that it was absolutely impossible in the present state of knowledge to arrive at any definite conclusion. It was only to be hoped that many persons might be induced to bring their attention to this subject. He begged to move a vote of thanks to the President for his Address, and to ask that it might be printed and circulated in the usual way.

Dr. Matthews said he had listened with the greatest interest to the address, in the course of which it appeared that they had been taken upon ground hitherto absolutely untrdden, and he did not suppose it possible that any living man could have gone much further. He had great pleasure in seconding the vote of thanks.

Mr. H. J. Slack believed that no Society had been favoured with an address of greater importance, from the interest of the facts and the wide range of the suggestions, than the one to which they had

\* Those with an asterisk before their names are new members.



## BOOKS PURCHASED.

Quarterly Journal of Microscopical Science.  
Annals of Natural History.  
Proceedings of the Royal Society.  
Micrographic Dictionary, Third Edition.  
Mycographia Icones Fungorum. Part 1.

## APPARATUS, SLIDES, &amp;C.

Turn-table, from C. F. Cox, Esq., U.S.A.  
Eight Slides.  
Box of Minerals, &c., from Mr. Hanks, of San Francisco.

A selection of these last objects have been beautifully mounted by W. T. Loy, Esq., and placed in the Society's cabinet.

## PAPERS OF THE SESSION 1875-6.

The papers read before the Society during the past year will by reason of their variety and importance bear favourable comparison with those of any previous period. Arranging them according to subjects, we find

*Natural History.*

"Further Researches into the Life History of the Monads," by W. H. Dallinger and J. Drysdale, M.D., read May 1st, and concluding the series commenced in 1873.

Paper on "Bog Mosses," by Dr. Braithwaite, finishing the series commenced in July, 1871, the whole supplying descriptions and figures of all the known European species.

"A Rotifer named *Melicerta* (Tyro)" was described and figured by Dr. Hudson, October 6th.

The imperfectly known "Entozoon *Bucephalus polymorphus*," was the subject of remarks by Mr. Badcock, in April, to which Mr. Slack appended notes translated from Von Baer and other observers; and Mr. Stewart contributed further information in the July number. The "Absorptive Glands of Carnivorous Plants" were described and figured by Professor A. W. Bennett, on December 1st.

"Perforating Proboscis Moths" were brought under the notice of the Society by Mr. Slack (on October 6th), calling attention to a paper read before the French Academy on certain Australian species, throwing light upon a slide presented to the Society in April, 1874, by Mr. McIntire, the first European observer of a perforating organ belonging to a lepidopter.

The "Markings of *Frustulia Saxonica*" formed the subject of a note by Dr. Woodward, read on November 3rd.

The "Variability of Form of the Foraminifera, and especially of the Crustaceans," was elaborately illustrated in a paper by Professor Rupert Jones, read on December 1st, and published in the 'M. M. J.' for February.

*Apparatus and Optics.*

The President (H. C. Sorby, Esq.) described "A New and Improved Microscope Spectrum Apparatus, and its Applications to

various purposes of Research;" on November 3rd, "A New Method of Measuring the Position of the Bands in Spectra," so as to secure uniformity of standard and accuracy of result.

"On the Principles of Testing Object-glasses by Miniatures of Illuminated Objects examined under the Microscope," by Dr. G. W. Royston-Pigott, F.R.S., November 3rd; by the same author, "On the Identical Characters of Chromatic and Spherical Aberrations," October 6th.

"On the Method of obtaining Oblique Vision of Surface Structure under the Highest Powers of the Microscope," by F. H. Wenham, March 3rd.

"On the Measurement of Angular Aperture," by J. W. Stephenson, June 2nd.

"On Angle of Aperture in Relation to Surface Markings," by H. J. Slack; and by the same, May 5th, "Notes on the Use of Mr. Wenham's Reflex Illuminator," June 2nd.

#### SCIENTIFIC EVENINGS.

During the past year the Society has held two Scientific Evenings, which have been well attended, and remarkable for the number of interesting objects exhibited. They have also been successful in promoting the friendly intercourse of Fellows.

Eleven gentlemen have been elected Fellows during the year, and the Society has to regret the loss of nine ordinary and one honorary Fellow by death.

#### OBITUARY.

DANIEL HANBURY, eldest son of Daniel Bell Hanbury, of the well-known firm of Allen, Hanburys, and Barry, was born Sept. 11, 1825. He was best known in connection with the Pharmaceutical and Linnean Societies, of which latter he was the treasurer at the time of his death, having performed the duties of that office for some years. As is well known, he had assiduously and successfully directed himself to the study of the various vegetable products used as drugs. No trouble, or expense, was thought by him too much to clear up the obscurity which did, and which still does, exist respecting the origin of many of these products. No less than sixty papers by him on such subjects are contained in the 'Pharmaceutical Journal.' His great work was the 'Pharmacographia,' written in conjunction with Professor Flückiger, published in 1874; but he was also the author of various other essays connected with his favourite subject. He was a valuable friend of the Pharmaceutical Society, and his exertions and example contributed effectively to the improvement of the education and status of chemists and druggists.

Mr. Hanbury made a very important collection of drugs and pharmaceutical preparations. He was acquainted with several European languages and skilful in water-colour drawing. He belonged to the Society of Friends. He was a Fellow of the Royal and Chemical



Societies, and was on the Council of the former at the time of his death, which took place at Clapham on the 4th March, 1875, from typhoid fever supervening on an attack of inflammation. He was elected a Fellow of this Society on the 12th June, 1867.

HENRY TURBERVILLE joined this Society on the 14th November, 1866, and died August, 1875. He devoted much time and money to the collection of object-glasses best adapted to display lined objects, and up to his death exhibited great interest in every optical contrivance likely to facilitate this result.

THOMAS HENRY HENNAH was the eldest son of Mr. Thomas Hennah, of the H.E.I.C., and was at the time of his death, January 8th, 1876, in his fiftieth year.

He took up his residence in Brighton about twenty-five years since, and turned his attention to photography, then in its infancy. After carrying on a series of experiments, he entered into partnership with Mr. Kent, and founded the firm of "Hennah and Kent," which from the excellence of their productions attained a European reputation. He was the first to introduce to Brighton the Talbotype process, and to improve upon it so much that at the request of the Photographic Society of London, of which he was a Council member, he detailed his improvements in printing. A small manual on the Negative Process, published by Mr. Hennah, is still a text-book. About twenty years ago he became a member of the Brighton and Sussex Natural History Society, and in 1861 was elected on the Committee, and in 1869 was made President of the Society; in accordance with the rules of the Society, on retiring from the Presidency he became a Vice-President, and held that office up to his death. The first paper communicated to that Society was in April, 1870, on "Soundings made by Sir Edward Parry in the Arctic Seas, in 1818." During his year of office, and mainly through his exertions, a Microscopical Section, "which should provide further study of objects connected with the use of the microscope," was added to the Society, and in September, 1870, it was determined to continue its meetings once a month, but as a part of the organization of the Society. (They have continued since, and the Society meetings are bi-monthly instead of monthly.) The inaugural address to the Microscopical Section was delivered by Mr. Hennah, May 26, 1870, on "Systematic recent Examinations with Moderate Powers." So long as health and strength would allow he was a regular attendant at the microscopical meetings, and read before the Society papers on the following subjects: "Gundlach's Lenses," Dec. 22, 1870; "Animal Parasites—Entozoa," Nov. 23, 1871; "Palates of Mollusca," Feb. 22, 1872; "Minute Crustaceans," June 27, 1872; "New Series of Lenses, by Wenham," Sept. 26, 1872; "Scales of Fish," April 24, 1873; "Illumination," March 26, 1874.

In addition to the foregoing papers, he gave practical lessons to the members in mounting and section cutting, and the preparation of objects for the microscope, and contributed to the Society's cabinet many fine preparations made and mounted by himself.

In conjunction with Dr. Addison, F.R.S., he formed, in 1860, a small Microscopical Club, the members of which met at each

other's houses for fourteen years, during which time many interesting subjects were discussed and worked out. His opinion on all matters relating to the microscope was held in such esteem that almost every one who had worked with that instrument in Brighton during the last twenty years is indebted to him for advice, assistance, or instruction, which he was always ready and willing to give, even though at times suffering from great physical debility, to the mere tyro equally with the advanced student. In private life all who came in contact with him speak of his uniformly affable and gentlemanly bearing, and of the genial way in which he conveyed information to others.

He was elected a Fellow of this Society on 13th June, 1866.

The Secretaries have not been able to obtain any biographical information concerning the following:

St. Thomas Baker, elected Dec. 11, 1867, died Oct. 14, 1875.  
 Frederick Barber, elected June 20, 1849, died ———.  
 Benjamin Miller, M.R.C.S., elected Dec. 11, 1867, died ———.  
 James Robinson, elected Jan. 10, 1866, died ———.  
 Robert S. Stedman, M.R.C.S., elected Jan. 14, 1857, died ———.  
 William Wright, elected May 11, 1864, died April 28, 1875.  
 M. Mouchet, elected an Hon. Fellow Jan. 12, 1870, died ———.

Donations to the Library since January 5, 1876:

Nature. Weekly .. .. .	From <i>The Editor.</i>
Athenæum. Weekly .. .. .	<i>Ditto.</i>
Society of Arts Journal .. .. .	<i>Society.</i>
Transactions of the Northumberland and Durham Natural History Society. Vol. V., Part 2 .. .. .	<i>Ditto.</i>
Journal of the Quekett Club. No. 30 .. .. .	<i>Club.</i>

The Rev. Lewis G. Mills, LL.D., was elected a Fellow of the Society.

WALTER W. REEVES,  
*Assist.-Secretary.*

[www.libtool.com.cn](http://www.libtool.com.cn)

Fig. 1.

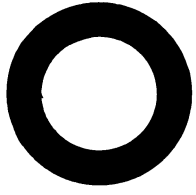

Fig. 2.



Fig. 3.



Fig. 5.

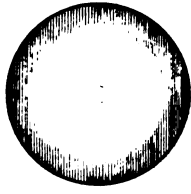

Fig. 4.

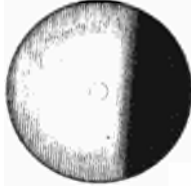

Fig. 7.

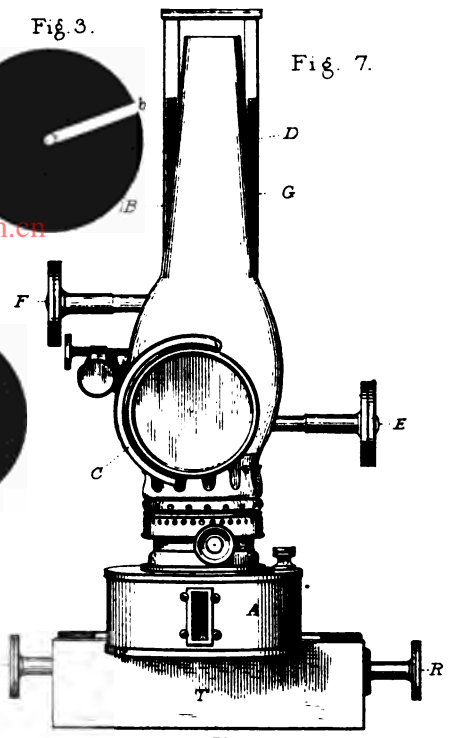
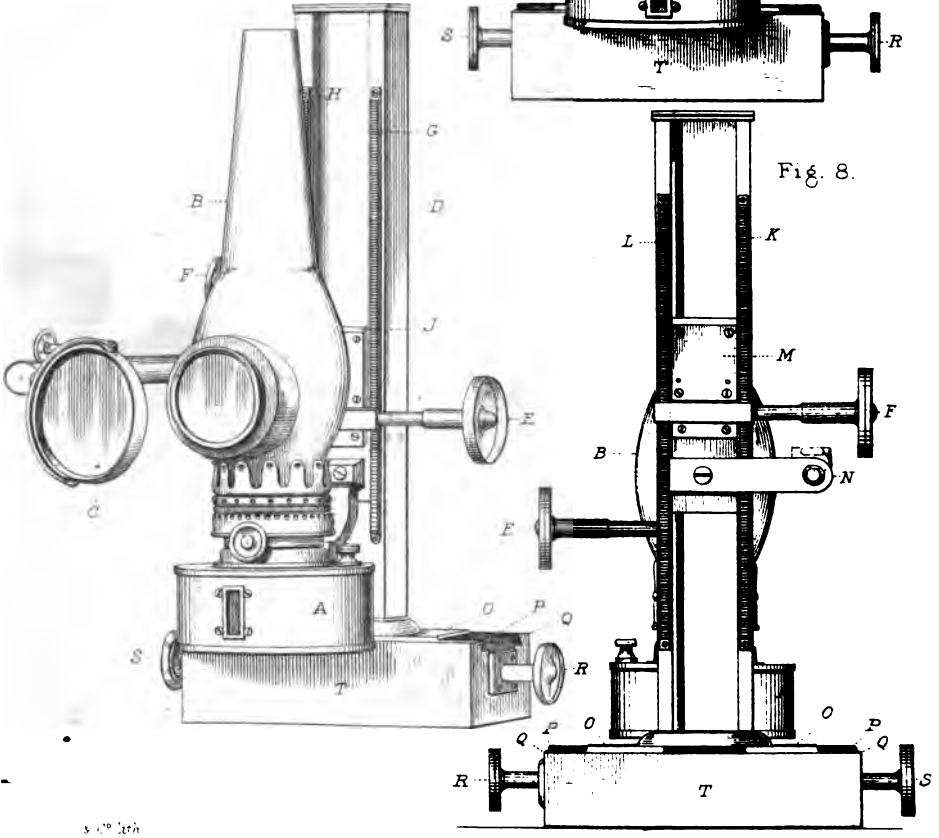

Fig. 6.



3 1/2 inch

M<sup>r</sup> Dallinger's new microscope lamp.

THE  
MONTHLY MICROSCOPICAL JOURNAL.

www.libtool.com APRIL 1, 1876.

I.—*On a New Arrangement for Illuminating and Centering with High Powers.* By Rev. W. H. DALLINGER, V.P.R.M.S.

(Read before the ROYAL MICROSCOPICAL SOCIETY, March 1, 1876.)

PLATE CXXXI.

ALL who have been engaged in prolonged research, with the highest powers at the present disposal of the microscopist, will have discovered the practical value, not only of a delicate adjustment of the illuminating pencil, but also of an *accurate* incidence of the axis of the sub-stage combination, employed as a condenser, with that of the object-glass itself. The value of this was very amply demonstrated to Dr. Drysdale and myself in our protracted employment of high powers in our Researches on the Monads.

On the subject of delicate centering, our best text-books say but little, and for powers beyond the  $\frac{1}{12}$ th the methods in common use appear to me to fail,—at least in obtaining the delicacy of result which we have found to be possible.

Of course the theory of “centering” is that the optical axis of the microscope should, by being prolonged, become accurately the optical axis of the condenser. For this, in the first place, when high powers are employed, there can be no “centering of the instrument” in preparation for the successive reception of two or three different powers. However delicate the workmanship, there is a displacement in the transfer of powers, which, although of no moment in the use of the  $\frac{1}{8}$ th,  $\frac{1}{10}$ th, or  $\frac{1}{12}$ th, is, in practice, when the best results are sought, of the utmost moment when a change is made from the  $\frac{1}{8}$ th to the  $\frac{1}{12}$ th, or from that to the  $\frac{1}{10}$ th. Each glass must be centered for itself.

For such centering, a simple cap pierced with a central hole of about the one-twentieth of an inch, and placed upon the optical combination of the condenser, is often employed. But it fails wholly to accomplish the desired end; while, as we shall presently see, the use of a “centering glass” can only result in the accomplishment of part of the end we know to be desirable, even if the apertures of the diaphragms be made small enough for the highest powers.

We now employ a very accurately centered diaphragm, under the optical combination of the condenser; this is pierced with great care centrally, the aperture having a diameter of not more than the

ninetieth or the hundredth of an inch. By means of the centering screws, this is brought carefully to the centre of the field of a moderate power. If the illuminating pencil be now carefully manipulated, and the  $\frac{1}{16}$ th objective put on, it will be found that the image of this aperture can be brought to a focus, presenting a central disk of light with a margin of the black diaphragm as seen in Fig. 1, Pl. CXXXI, which presents the aspect of the "field."\* This appears like centering, and is what we have been usually led to consider, from the methods employed, would be such.

Now with this very minute aperture in the field take off the  $\frac{1}{16}$ th objective, and put on a well-corrected  $\frac{1}{4}$ th. In all probability the disk of light will now be very eccentric, and it must be adjusted again to the centre. This being done, we are led again to suppose that the instrument is centered. But if now the mirror, or still better the rectangular prism be moved to a greater or less angle than that which gives a mere disk, a shaft of light will strike up in the opposite direction; and by changing the position of the mirror, the direction of this shaft will of course be changed as in Figs. 2 and 3, where the beam *a, b* is directed from opposite sides of the mirror. This pencil of light is of course at an angle with the plane of the diaphragm, but this effect is not readily produced in a drawing. Now if fortune favours, by some happy movement in the position of the lamp or prism, or both, we may change this beam or shaft of light into an exquisite illumination extending over half (or even more) of the field, as shown in Fig. 4; and we found, in some measure by accident, that this minute aperture could be made to illuminate the whole field. In this condition it presents the appearance of a minute intensely bright sun in the exact centre of the field, with an equal diffusion of rays all round, except that the intensity of the light grows uniformly less as it reaches the margin of the field. Fig. 5 is scarcely more than a diagrammatic rendering of the effect.

Now when we had obtained this light, and used it with the  $\frac{1}{8}$ th and  $\frac{1}{16}$ th, we were simply astonished at the beautiful results we obtained—results certainly not to be secured by any other means. It opened up structure, and displayed detail in the minute organisms we were studying in a way which gave us hope and pleasure.

For many of our purposes—such as working out the interior structure of a monad, or studying the changes in a nucleus, or discovering the earliest internal evidence of self-division—nothing was equal to this absolutely central illumination, which gave (properly managed) a wealth of light, a delicious field to work with, and simply incomparable results. We found that, however it was to be accounted for, we had fallen upon a fortunate method. But, alas!

\* Of course it will be understood that the centering screws will be brought again into requisition to perfectly centre the disk when the  $\frac{1}{16}$ th is put on.

its repetition was the difficulty. We had seen it—both of us—nay, we had spent hours in the enjoyment of the profit of the light it gave. But manipulate as we would, we could not repeat it. So we gave it up; and [then, by comparative accident, we secured it again! What could be the secret of its appearance? It was not the centering as usually employed, that was palpable; to all appearances it was not wholly dependent upon the angle of the mirror, for that was moved to every conceivable angle scores of times, and for hours together, on different occasions, without result. The amount of difficulty in securing this illumination may easily be tested. Some of the most accomplished microscopists, who have seen it, or to whom it has been described, have failed entirely by ordinary means to reproduce it. At length, however, we saw clearly that the whole secret was, after the ordinary centering was complete, dependent upon the position of the image of the flame upon the prism or mirror. We invariably use the flame edgeways to the instrument, and employ a broad wick, so as to get depth of flame; and the effect was always secured, although with great difficulty, by minute alterations in the height, or lateral position of the light, so that, as it appeared, a certain point in the image of the flame was *exactly under the optical axis of the condenser*. This was so manifest to both of us, that Dr. Drysdale devised a small piece of apparatus that would specially apply to our needs—but only to them. We had to work always with the instrument perpendicular; so he had a small plane silver speculum placed under the condenser at an angle of  $45^{\circ}$ , but so *narrow* that it was easy in comparison to direct the image of the flame to the right place. But this was nevertheless difficult of adjustment, and involved alteration every time; for even the different height of the wick, or the least change in the position of the lamp, was fatal to the result.

It was thus quite clear that what was needed was a lamp, *with delicate motions in all directions*; and such a lamp I have devised, with the most satisfactory results as to the accomplishment of the special end in view—the central illumination already described.

In Fig. 6 the lamp is figured so as to present its general aspect. A is the reservoir and lamp; B the chimney; C the bull's-eye condenser; D is the pillar which carries the lamp and condenser, separately, up and down, by means of the milled heads E, F (which are better seen in Fig. 7) and the racks. The racks are placed on either side of the pillar, back and front. The front ones are indicated at G and H, Fig. 6, and by means of these the lamp, which is fastened by an arm to a piece of metal J which works in grooves, is carried up and down by the milled head E. At the back of the pillar is another pair of racks, seen at K, L, Fig. 8, which by the milled head F carry up and down a piece of metal M, to which the arm of the bull's-eye N is attached. By



these means the lamp and condenser have separate vertical motions. But to accomplish the desired end we now want to be able to move the whole pillar, lamp, and condenser, from side to side. To accomplish this the pillar is fixed to a solid piece of metal O (Fig. 6), which fits accurately into the grooves P, Q in the solid base of the lamp T; and by means of an endless screw motion the entire pillar and lamp and condenser are carried horizontally to the right and left, by the milled heads R, S, precisely as the mechanical stage of a microscope is moved in the same directions. Thus a rectangular motion of a delicate kind is given to the source of light; and it is easy to find the spot on the prism or mirror where the image of the flame best secures the central illumination desired, and shown in Fig. 5; for the illuminating apparatus can be worked while the eyes are engaged with the microscope. Thus instead of the uncertainty and weariness, often ending at last in failure, of pushing the lamp from place to place, we can with comparative ease get the central light we need, which as a rule I find it best to get with the  $\frac{1}{4}$ th first, and then in putting on the  $\frac{1}{2}$ th or  $\frac{3}{4}$ th, a very slight readjustment secures with these powers the same result.

The drawing of the apparatus is made to a scale of one-fourth, and the letters in each point to identical parts of the instrument.

What the explanation of this illumination may be I do not attempt to consider. The fact that this light can be got, the fact that it can only be got with the utmost difficulty with an ordinary lamp, and the fact of the immense value of such light in *all* delicate biological investigations with high powers, every expert microscopist may demonstrate for himself.

The value of the method is not, however, confined to the use of absolutely central rays, although it is in this that its supreme value consists; but it has a demonstrable value when we use larger apertures, and the stops, for the resolution of test-objects. I have invariably secured the finest results with the most difficult tests by means of Powell and Lealand's supplementary stage and small plano-convex condenser, which sends in the beam at as large an angle as may be desired, only from one point; therefore securing shadows if they exist at all, or are within the compass of the power used. But if the usual condenser\* be centered and illuminated as before described, and then the stops and apertures be carefully employed, and the mirror gently manipulated, and at times the lamp altered the minutest fraction, as experience will teach, the very best attainable results may be secured. In this way I have resolved with Powell and Lealand's new immersion  $\frac{1}{4}$ th *Frustulia Saxonica*,† *Amphipleura pellucida*, *Navicula rhomboides* (the dots

\* It may be well to say that it is Powell and Lealand's sub-stage condenser that we have used throughout.

† Two specimens from Germany and two specimens supplied by Mr. Wheeler; but only the transverse striae were seen.

beautifully clear in the part best in focus, and cross lines all over the remainder), and *Surirella gemma* (the dots being sharply separated). These results are not given as extraordinary in themselves, as I believe they have been accomplished with the same power by ordinary methods. But so far as my own experience is concerned, the *ease* with which they are secured with this apparatus, is scarcely to be compared.

I have also found this lamp of great service in the use of that difficult piece of apparatus a *vertical illuminator* for opaque illumination with high powers, the command possessed over the position of the flame tending to give results not otherwise attainable. This is specially the case when examining dry bacteria or monads opaquely with a  $\frac{1}{12}$ th or  $\frac{1}{15}$ th.

The same to some extent will apply to the use of the *silver side reflector*. The power to dispose of the image of the flame as may be desirable, as easily as the position of the object on the stage of the instrument, greatly facilitates richness of illumination.

But it will be seen that all but the first result claimed for this piece of apparatus and the method of using it, are more matters of convenience or luxury than anything else. They can be accomplished without it. But to get the particular central illumination referred to, some such apparatus must be employed; and the *value* of that illumination, in minute investigations on organic structures with the highest powers, *cannot well be over-estimated*.

The instrument has been beautifully made, first for myself, and then for Dr. Drysdale, by Mr. G. S. Wood, of the firm of (late) Abraham and Co., Liverpool.

---

## II.—*The Identification of Liquid Carbonic Acid in Mineral Cavities.*

By WALTER NOEL HARTLEY, F.C.S. (King's College, London).

(Read before the ROYAL MICROSCOPICAL SOCIETY, March 1, 1876.)

### PLATE CXXXII.

IN 1822 Sir Humphry Davy\* investigated the contents of fluid cavities in rock-crystals from different localities. His researches showed that in almost every case the liquid was nearly pure water.

About four years ago I bought from Mr. Norman, of the City Road, a microscopic slide of quartz with fluid cavities. One good sized cavity was readily seen with a 2-inch objective; it exhibited when under the microscope the shape and appearance of Fig. 1, Pl. CXXXII. Its entire length was  $\frac{1}{8}$  of an inch, and its average breadth  $\frac{1}{30}$  inch. The liquid at once recognized is indicated by *b*.

Being acquainted with the experiments of Cagniard de la Tour, I resolved to repeat them with this specimen, and therefore, proceeding cautiously, warmed the slide over a lamp, until it was just too hot to be touched with comfort. On examination, the liquid, to my surprise, was not to be seen, and the cavity under these circumstances appeared like Fig. 2. As the temperature to which the fluid had been subjected was but little above that of boiling water, I concluded that it had escaped from some minute and invisible opening; continuing, however, to observe the object until it became cold, I was gratified to see a sort of flickering movement within the apparently empty space of the cavity, followed by the replacement of the liquid, as at first. The extremely low temperature at which only the substance assumes the liquid state, made me at once desirous of ascertaining the exact conditions under which the liquid is dissipated and reproduced; for the researches of Professor Andrews,† “On the Continuity of the Gaseous and Liquid States of Matter,” have told us that at a temperature of 88° F., or 30°·92 C., liquid carbonic acid becomes a gas, and a pressure of even 300 or 400 atmospheres will fail to condense it to liquidity. This temperature is called the critical point. To determine the critical point of the new fluid, immersing the slide in water of known temperature, removing, wiping it hastily, placing it on the microscope stage, and instantly examining it, seemed preferable to any other mode of operating, and although other more promising methods have been tried, the results obtained have been less accurate.

1st Experiment. The liquid in the two cavities had disappeared completely at 36° C.; the cavities appeared empty, but the liquid

\* ‘Phil. Trans.,’ 1822, p. 367.

† ‘Chem. Soc. Journ.,’ 1870, p. 74.

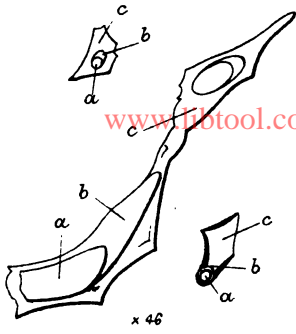

Fig. 1.

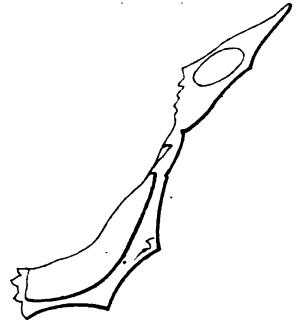

Fig. 2.

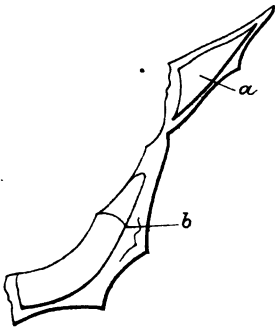

Fig. 3.

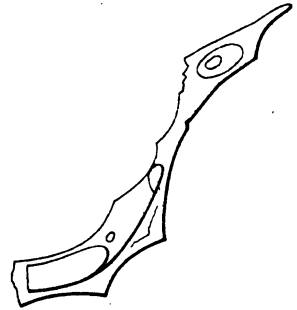

Fig. 4.

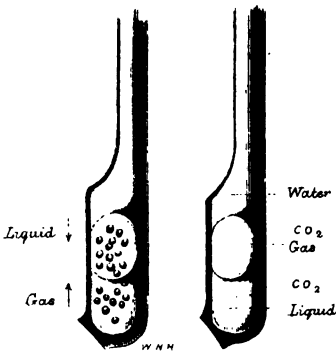

Fig. 6.

Fig. 5.

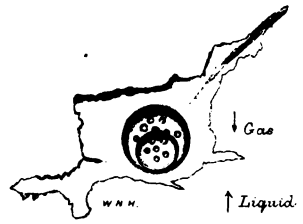

Fig. 7.

x 250

Liquid Carbonic acid in micral Cavities

[www.libtool.com.cn](http://www.libtool.com.cn)

returned after a short interval. 2nd. The liquid had totally disappeared at  $31^{\circ}\cdot5$ , and returned on cooling. 3rd. The liquid was invisible at  $31^{\circ}$ , but returned almost immediately after contact with the microscope stage. 4th. At  $31^{\circ}$  there was no liquid to be seen, but it was observed to be filling in immediately afterwards. 5th. Again at  $31^{\circ}$  did the liquid vanish. 6th. At  $30^{\circ}\cdot75$  the margin of the liquid was visible, but was not so sharply defined or so high up in the cavity as it afterwards became. 7th and 8th. On being warmed almost to  $31^{\circ}$ , the liquid was still visible, but the margin became more distinct immediately afterwards. 9th. At  $31^{\circ}\cdot5$ , liquid invisible. 10th. At  $31^{\circ}$ , upper portion of the liquid invisible; lower one not. 11th. The liquid invisible at  $31^{\circ}$ , in the upper cavity, but not in the lower. 12th. At  $30^{\circ}\cdot75$  the liquid was seen in the larger cavity; the quantity, however, increased to treble immediately afterwards. 13th. At  $31^{\circ}$  the upper cavity appeared empty; the lower one full. It is evident, then, that the critical point lies between  $30^{\circ}\cdot75$  and  $31^{\circ}$  C. The critical point of pure carbonic acid, as determined very precisely by Andrews, lies at  $30^{\circ}\cdot92$  C., or very nearly  $87^{\circ}\cdot7$  F. Hence I conclude that the identity of this liquid with carbonic acid is established in a most convincing manner. It was noticeable that in whatever position the slide was placed, the liquid generally condensed on the same spot. Varying the method of heating the liquid by applying a hot wire to the surface of the quartz, I discovered what was at first by no means apparent, namely, that the upper and lower cavities were connected by a small fissure, and that water occupied the intervening space; the upper cavity was then seen to have the shape drawn in Fig. 3, and marked *a*. This presence of water, no doubt, determined the place of condensation, so that no matter what the position of the specimen, the carbon dioxide always condensed on the surface of the water, because of its adhesion to this fluid being greater than to the quartz. The concavely curved surface of the carbon dioxide is due to adhesion to the moist sides of the cell; the convex curvature indicating where the two liquids are in contact is caused by the greater adhesion of the water to the same surface. Before the specimen had been heated in such a way as to drive the liquid from the smaller into the larger cavity, it contained more of the carbonic acid than has collected in it since, and it was noticed on two or three occasions, that the action of heat was to diminish the gas-bubble very rapidly, by expansion of the liquid, until it had the appearance shown in Fig. 4; the bubble then as quickly increased in size, by contraction of the liquid to its original dimensions, when the source of heat was removed; likewise, when the heat was continued, the gas-bubble increased by vaporization of the liquid, as in Fig. 2. The appearance caused by the expansion and contraction resembled the dilata-

tion and contraction of the pupil of the eye. Since the connection between the cavities has been made by excessive heating, the expansion and contraction cannot be shown; the liquid at once begins to vaporize, when warmed, and even boils, as is shown in Fig. 4. The following observation of Thilorier explains this. When a tube containing liquid carbonic acid is one-third full, at  $0^{\circ}$  C., it constitutes a *retrograde thermometer*, in which increase of temperature is shown by diminished volume, consequent on the vaporization of the liquid, and *vice versa*; while if the tube be two-thirds full, a *normal thermometer* of great sensitiveness is the result, the liquid expanding by heat in this case.\*

Very careful observation several times repeated has shown that on the approach of a warm substance, causing the liquid in the larger cavity to be vaporized gradually, the curvature of the surface in contact with the gas becomes reduced very much, and at the same time rendered less plainly visible, as shown by *b*, Fig. 3.

There was also noticed a faint flickering shadow in the point of the cavity, when the liquid was about to condense. Professor Andrews has noticed such effects during the vaporization and condensation of liquid carbonic acid. In the same section of quartz there were observed upwards of fourteen smaller cavities, containing liquid carbonic acid, together with water in different proportions. There are two such cavities shown in Fig. 1; in each case the space marked *a* contains carbonic acid as gas; *b*, the same substance liquefied and floating on the water, which, being indicated by *c*, is seen to be occupying the remaining space.

According to Thilorier, the specific gravity of liquid carbonic acid is 0.83 at  $0^{\circ}$  C., and 0.6 at  $30^{\circ}$  C., water being taken as unity. The constant position of this liquid in the cells being uppermost is in accordance with this.

Volatile fluids have been noticed in mineral cavities by Sir David Brewster,† by the late Mr. Alexander Bryson,‡ and by Messrs. Sorby and Butler, who came to the conclusion that the liquid in a particular cavity in a sapphire was really liquid carbonic acid, because it possessed a remarkable rate of expansion between  $0^{\circ}$  and  $30^{\circ}$  C. Thilorier has shown that the expansion of liquid carbon dioxide between  $0^{\circ}$  and  $30^{\circ}$  C. is such, that 100 volumes become 145. Sorby found that 100 volumes of the liquid he examined became 150 at  $30^{\circ}$  C., 174 at  $31^{\circ}$  C., and 217 at  $32^{\circ}$  C.§

Through the kindness of Mr. Butler, I have had the advantage of examining some of the best specimens from his unique collection of stones with fluid cavities, and I have no doubt that the con-

\* 'Ann. Chim. Phys.' [2], lx. 249.

† 'Trans. Royal Society of Edinburgh,' vol. x., p. 1, 1823.

‡ 'Proceedings of the Royal Society of Edinburgh,' 1860-1.

§ 'Proc. Royal Society,' vol. xvii., p. 299; also 'Transactions of the Royal Microscopical Society,' vol. i., p. 222.



clusion which he and Mr. Sorby arrived at was a just one. By a very simple contrivance I have been enabled to detect the presence of liquid carbonic acid in many very small cavities containing water. This consists of a glass tube about three-eighths of an inch in diameter and twelve inches long; it is drawn out to a jet at one end of about one-sixteenth of an inch aperture, the jet being bent at an obtuse angle. To prevent the glass being softened and bending when heated, it is covered for four inches in its central part by a piece of brass tube which slides on not too easily. The straight end of the tube is somewhat pointed, and passes through an india-rubber cork fitting into a universal joint upon a stand having a sliding motion in the upright so that it may be raised or lowered at will. This end of the glass tube which has passed through the cork has a piece of india-rubber tube slipped over it fifteen inches long, and to this is attached a ball syringe whereby air may be drawn in and discharged again. By heating the metal tube with a spirit lamp or Bunsen burner, the air discharged will be heated and may be directed on to the object while undergoing examination beneath the microscope without any displacement whatever, by which means a high power may be used for the examination of small cavities. By noticing the number of ballfuls of air necessary to vaporize a known specimen of carbonic acid, one may, if these be sufficient to vaporize the liquid in small cavities, be certain that the temperature is not greatly different. It is easy to demonstrate the presence of small quantities of carbonic acid mixed with water in cavities no larger than  $\frac{1}{1700}$  of an inch in their greatest diameter.

After carbonic acid has passed its critical temperature, if it be cooled suddenly it condenses with a motion resembling ebullition. This is best seen in deep cavities. Messrs. Sorby and Butler have observed this phenomenon.\* Having attentively studied it in different cavities, I have come to conclusions as to the meaning of it. When the gas is chilled, a sort of mist forms throughout the space; the individual spherules of this mist grow so large that they begin to touch each other, to coalesce, and to gravitate. They of course at the same time entangle gas, and as they descend to the lower part of the cavity the spherules of gas (bubbles) take an opposite direction; consequently when a portion of the liquid has collected at the lower end and gas at the upper, there are showers of liquid descending into and streams of bubbles rising out of the liquid. In two or three seconds the movements have ceased. In Figs. 5 and 6 are given representations of a fluid cavity in topaz belonging to Mr. James Bryson, of Edinburgh, to whom I am much indebted for allowing me to examine some of his valuable specimens. When at a temperature two or three degrees below the

\* 'Monthly Microscopical Journal,' vol. i., p. 222.

critical point, the liquid has the appearance seen in Fig. 5, but the boiling is shown in Fig. 6—the *spherules* called *gas* and *liquid* are passing in the direction of the arrows nearest them. The drawing, Fig. 7, represents a cavity seen in one of my specimens of quartz; the contents are undergoing the apparent boiling. The conditions favouring this singular mode of condensation seem to be, first, that the greater part of the carbonic acid shall be in the liquefied state at ordinary temperatures so that the liquid expands greatly on approaching the critical point; second, that the cooling shall be sudden.

Cavities containing liquefied carbonic acid may be divided into two classes, *wet* and *dry* cavities, according to the absence or presence of water. The appearance of the liquid in a dry cavity differs much from that in a wet one. Thus in a dry cavity the liquid presents a convexly curved surface to the gas, in a moist one a concave surface. While the carbonic acid in sapphires and rubies seems generally to be dry, that met with in quartz and other minerals is more frequently wet.

Another means of ascertaining the critical temperature of the liquid in fluid cavities was resorted to. It consisted in making a water-tight cell with glass sides, which would contain besides the mineral under examination the bulb of a small thermometer three inches in length and graduated into one-tenths of a degree Centigrade, between 29° and 35° C. An inlet and outlet tube of india-rubber conveyed a stream of warm water, forced through the cell from a small flask by means of the pressure of a large india-rubber finger-pump or syringe. The entrance and exit for air to and from the syringe was by valves in different branches of a T tube.

The walls of the cell were made by boring a hole an inch in diameter through an india-rubber cork of the diameter of 1½ inch. Two perforations one-eighth of an inch in diameter were made in the side of this to admit the water tubes, and a third for fixing the thermometer in. The glass slides placed top and bottom of the ring were firmly fixed by passing stout india-rubber bands over them. When the cell was placed on the microscope stage, a powerful Coddington lens was so arranged in position near the thermometer that without the slightest movement the cavities could be watched through the microscope with the left eye, and simultaneously the mercury in the thermometer with the right. The cavity under examination was so arranged that it appeared just upon the edge of the lens. Admirable though this arrangement seems, it does not answer quite so well as one might expect. The volume of water in the cell is so small, that it changes temperature more readily than the slowly conducting mineral.

My original plan of immersing the mineral in a considerable volume of water at temperatures just above and below the critical

point, may be improved upon by placing the specimen in a glass cell with parallel sides and immersing this in water of known temperature; on removing this for examination, the sides of the cell may be wiped dry without fear of the mineral losing an appreciable amount of heat. Being now engaged in the study of other rocks and minerals, details regarding these had better be left for another communication. I have elsewhere shown\* the nature of the chemical reaction which would most probably yield quartz crystals with carbonic acid cavities, but this explanation could not be applied to the formation of topaz and sapphire.

\* 'Journal of the Chemical Society,' February 1876.

---

III.—*On some Structures in Obsidian, Perlite, and Leucite.*

By FRANK RUTLEY, F.G.S. (H.M. Geological Survey).

(Read before the ROYAL MICROSCOPICAL SOCIETY, March 1, 1876.)

## PLATES CXXXIII. AND CXXXIV.

In this paper I shall endeavour to demonstrate certain peculiar structures in spherulitic obsidian and leucite which appear to be, in some respects, analogous; and an explanation will also be attempted of the spheroidal structure which characterizes the vitreous rocks known as Perlites.

So far back as 1857 your President, Mr. Sorby, was at work with his microscope upon the pitchstones of Arran. Since that time Vogelsang, Zirkel, Allport, and others have made very considerable additions to our knowledge of the minute structures which rocks of this class contain.

The section of obsidian which I am about to describe was cut from a specimen collected by my friend, Mr. J. W. Judd, from a lava flow in the Isle of Lipari. The mode of occurrence of this lava stream is described in his "Contributions to the Study of Volcanos," published in the 'Geological Magazine,' 1875. The specimen is a grey glass, but when seen in moderately thick pieces by reflected light it appears black. Through this glass run parallel bands of white spherules, which are often elongated, and in most cases have coalesced so as to form either continuous parallel-sided bands (approximately cylindrical) or moniliform strings. Isolated spherules also occur in the specimen, and sometimes adhere to the sides of the spherulitic bands, as shown in Fig. 8, Pl. CXXXIII. The isolated spherules have a distinctly radiate structure, which in the bands formed of coalesced spherules is almost absent. Both the isolated spherules and the spherulitic bands are surrounded by a broad external crust, which by transmitted light appears of a reddish-brown colour, and is but feebly translucent, while by reflected light it looks almost snow-white. Within this lies granular or crystalline, and in some cases radiately fibrous matter, which in many instances exhibits a reddish, rusty colour, both by reflected and by transmitted light; while in others, although rust-coloured by transmitted light, it appears white or greyish white when viewed as an opaque object. At times this inner substance is sharply separated from the cortical layer by a thin, transparent, vitreous band. In the spherulitic bands there are usually other innermost bands which are more translucent and less rusty in appearance than the intermediate ones, and along these inner cores there frequently run lines of almost opaque bodies, giving, as a rule,

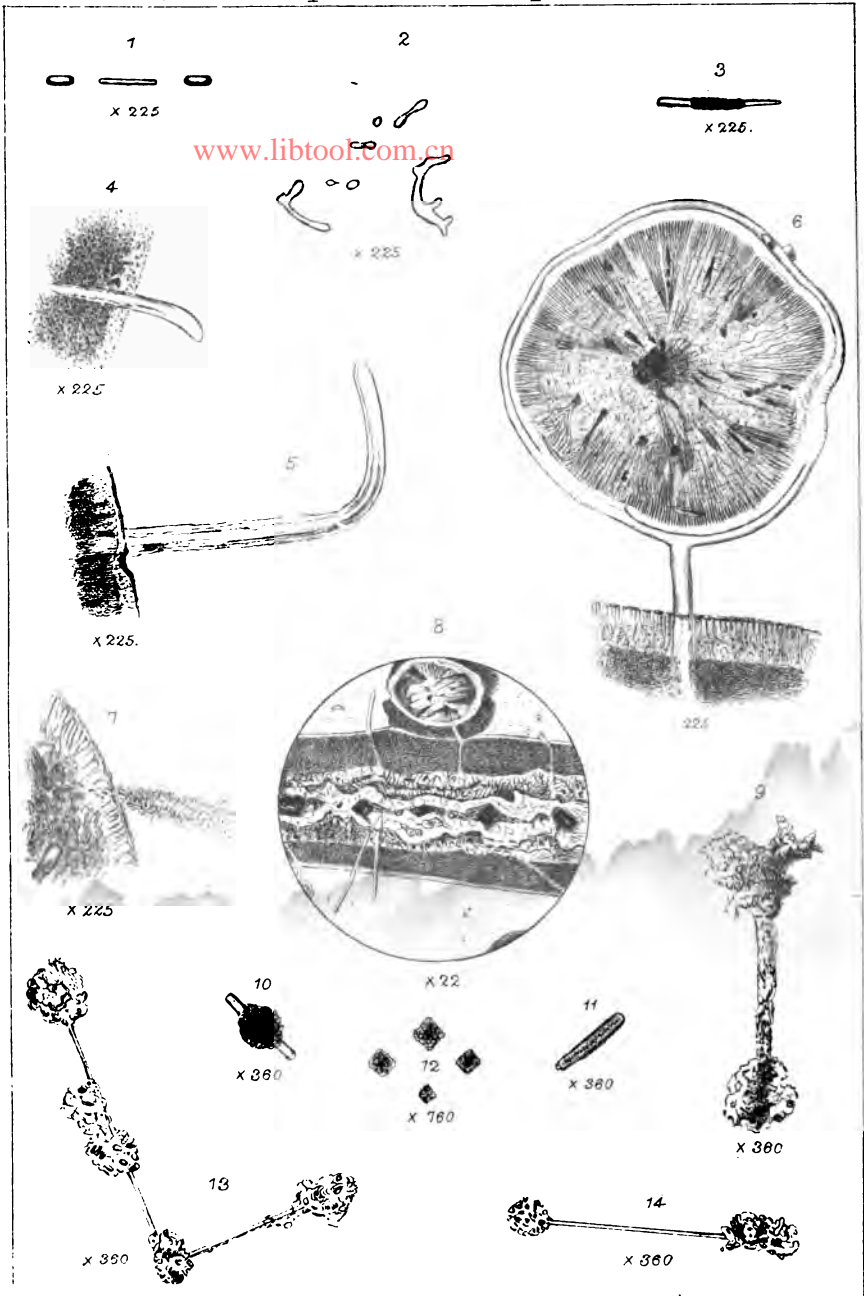

www.libtool.com.cn

Franklin & Co. del.

W. West & Co. sc.

Structures in Obsidian and Leucite.

[www.libtool.com.cn](http://www.libtool.com.cn)

[www.libtool.com.cn](http://www.libtool.com.cn)



*Perlite, etc.*

439

*Microscopical*

Structure in Perlite.



[www.libtool.com.cn](http://www.libtool.com.cn)

sections similar to those which an octahedron would yield (Fig. 8). They are often feebly translucent towards their margins. This probably results from peroxidation of the protoxide of iron which the mineral, if magnetite, would contain. I believe that these crystals are magnetite altered at their margins into limonite or possibly in some cases hematite. Lasaulx has noted the occurrence, in the altered lavas of Auvergne, of microscopic pseudomorphs of hydrated oxide of iron after magnetite, in distinct octahedra of a brownish-red colour and translucent.\* I merely record this point because, from the slight marginal translucency of these crystals, some doubt might be experienced as to whether or not they really represent magnetite. The hand specimen, from which the section was cut, attracts the magnetic needle, and seems, at certain spots, to repel it also to a very slight extent. Fig. 12 shows similar, but much smaller crystals, which are plentifully disseminated in the crystal of leucite, presently to be described, but they are so minute, as a rule, that unless magnified five or six hundred diameters they appear to be mere amorphous specks. At various points along the spherulitic bands in the obsidian, minute tube-like bodies may be seen under the microscope, with a quite low magnifying power (such as 20 diameters). The tube-like bodies appear to emanate from sometimes one, sometimes the other, of the inner layers of the spherulitic bands, pass through the outer zone, and protrude, often for a considerable distance, into the glassy, colourless obsidian. Sometimes they are seen to terminate in a rounded end, like the end of a test-tube (Figs. 4 and 5), but they are often cut off by the planes of section, which in some cases gives them the appearance of ending abruptly. After a careful examination of these forms, I have come to the conclusion that they are not tubes, but solid rods of glass. An inspection of the form shown in Fig. 6 may serve to render this point more apparent. Here, one of these rods is seen to pass through the cortical zone of a spherulitic band, and to completely surround an outlying, isolated spherule. Now there is no reason to doubt that this clear, glassy ring, which appears as a mere girdle in the section, is in reality a slice through a vitreous envelope which completely encased the spherule. Had this rod been a tube, and the envelope of the spherule merely a bulbous continuation of that tube, it is manifest that, whether vacuous or filled with a gas or a liquid, the enveloped spherule would infallibly have stripped out during the process of grinding the section; and even assuming that a vacuum existed between the cup and the piece of the spherule, and that by atmospheric pressure or by some accident it had remained *in situ*, there is little doubt but that some small amount of emery mud would have

\* 'Neues Jahrb. f. Min.,' 1870, p. 695.

worked into the line of contact, and thus attest the presence of a vacuity. Of this there is not the slightest trace, the cincture of the spherule being perfectly clear and glassy. Some of these glass rods issue at right angles from the spherulitic bands, others obliquely; some are more or less bent, occasionally almost at a right angle, as in Fig. 5. Here and there two rods may be seen to anastomose and pass out into the surrounding obsidian as a single rod. Fig. 7 represents a stream of granular matter projected through the cortical zone of a spherulitic band into the surrounding glass. Fig. 1 is a straight cylinder or elongated glass rod magnified 225 diameters. It has apparently been severed at two points equidistant from the ends, thus giving rise to three cylindrical forms, the two terminal ones being somewhat thicker than that in the middle. It is, however, possible that this supposition is incorrect, and that they are three elongated lacunæ of glass. If so, why do they lie in a perfectly straight line? a line parallel in direction with the larger spherulitic bands, i. e. in the direction of the lava flow. The tension in the direction of, and consequent upon, the flow of the molten matter, may even have sufficed to elongate and sever this rod. Has not this tension, coupled with strain necessarily more or less rectangularly situated to the direction of flow, also caused the cylindrical extrusions of glass from the spherulitic bands, or do the latter phenomena depend upon the contraction of the bands themselves, caused by an imperfect attempt at crystallization? Although, from the fact that these extruded glass rods are often curved in opposite directions, it may be assumed that they were uninfluenced by the direction of the lava flow, we must also bear in mind that they pass through the outer zones of the spherulitic bands in diverse directions, and consequently often issued more or less obliquely into the surrounding obsidian, and equal pressure upon an overlying surface would tend to curve them still more in the directions in which they respectively issued. It is probable that their solidification was very rapid. The innermost core in the spherulitic bands is usually doubly refracting; hence we may assume that devitrification was set up at certain points or along certain lines, these points being determined by the presence of some trifling impurity, such as a minute granule or crystal of magnetite. This devitrification results from the development of crystalline structure; the crystalline bands probably enveloped minute lacunæ of molten glass, and upon solidification contraction of the cryptocrystalline mass ensued, the outer crust of the bands became fissured, and the lacunæ of glass finding an outlet from the internal pressure of the band, escaped through the cracks in the rod-like forms in which we now see them. Finally, solidification of the magma ensued; but it is probable that these different processes took place almost syn-

chronously. This appears to me to be the most plausible way in which to account for the phenomena which occur in the section which we have been considering.

The following translation from Zirkel's 'Mikroskopische Beschaffenheit der Mineralien u. Gesteine' (p. 75) may here prove interesting, as indicating the existence of structures somewhat similar to those described, but due to a different cause:

"Some of the more rare enclosures of glass which occur within a glass mass are peculiar. They may be recognized from the fact that a tolerably concentric circle usually surrounds a dark, mostly spherical cavity, but lies at some distance around it, the intermediate part also consisting of glass which is as a rule identical with the surrounding glass; it is, however, at times clearer or darker. These glass enclosures in glass are probably due to a gas-bubble, surrounded by a thin envelope of molten matter, having broken loose from some spot and after reaching an adjacent part of the magma becoming fixed. That this is in fact the case, is proved by the circumstance that at times the matter surrounding the bubble has developed a finely fibrous structure to a certain extent around its zone of attachment in a somewhat radial manner."

A few points will now be noticed in connection with the microscopic structure so characteristic of Perlites: rocks which are closely related to pitchstone and obsidian. In these rocks a very peculiar, concentric, shaly structure exists, which has been described by Zirkel, Rosenbüsch, and other observers. In some perlites, microliths, trichites, crystals of magnesian mica and felspars, and also small spherules, very similar to those just described, occur. Some of the latter are surrounded by a clear girdle, like that shown in the Lipari obsidian, Fig. 6. It is possible that the glassy girdles of these isolated spherules may merely represent a structural differentiation, and that their union with the cylindrical processes may only be an accidental circumstance; their probably identical constitution and synchronous development having favoured their coalescence, so that no perceptible demarcation exists between them. Under the microscope a distinct fluxion texture is seen in many of the perlites, being rendered evident by granular matter and microliths lying in more or less continuous streams. These streams, which thus apparently represent fluxion planes, are traversed at all angles by fine fissures, which often intersect one another, and in thin sections I have not yet been able to find any instances in which these fissures traverse the perlitic spheroids, although the fluxion structure cuts across them in a very marked manner. On the contrary, I find that the spheroids are packed between these fissures, and there is even evidence that in places their forms have been affected or modified by the fissures, since they sometimes appear to be more or less compressed where they come in contact

with one of these cracks (Pl. CXXXIV.). Have we not here a structure analogous to the spheroidal structure sometimes seen in prisms of basalt? The divisional planes in the basalt, which by their intersections give rise to the prismatic forms, are assumed to result from shrinkage or contraction consequent upon solidification. These less regular little cracks in the perlitcs are unquestionably due to the same cause. In a paper, read the other day, by the Rev. T. G. Bonney, before the Geological Society, it was pointed out in a very clear manner that the spheroidal structure in basalt results also from contraction on cooling. Surely then if these spheroidal forms in basalt are not intersected by the planes which divide the basaltic prisms, but are enclosed by those planes, the prism-planes were the first formed, while the spheroidal structure resulted from subsequent cooling taking place along those planes. If this be a right interpretation, I believe that we have here, in these perlitcs, a clearly parallel case, and that the explanation of the spheroidal structure in basalt is equally applicable to this, hitherto unexplained, structure in perlite.

I shall now point out those structures which seem most worthy of remark in the section of a crystal of leucite which I have recently examined. It is imbedded in a somewhat opaque lava which also contains crystals of plagioclase, &c., and was procured from one of the lava streams of Vesuvius. Fig. 2 represents a few of many minute enclosures, some of which are of very irregular form; they have broad, dark margins, and seem to be devoid of bubbles, so that I think they may possibly be glass lacunæ. Fig. 3 is approximately a straight cylinder, and either contains a plug of granular matter or else is incrustated with it. Fig. 10 is a ball of granular matter apparently perforated by a microlith or small cylinder (similar figures are given in Zirkel's 'Mik. Beschaff. d. Min. u. Gest.,' p. 75). Fig. 11 is a similar cylinder free from granular matter. I speak of these bodies as cylinders, because I am uncertain whether they are hollow or solid, but I think that they are solid. Now the question arises whether Fig. 3 is simply a version of Fig. 11, but containing a plug of granular material, and if so, is Fig. 10 a similar cylinder to Fig. 3, but with a bulb blown in its centre, just as we might heat a piece of glass tubing and blow a bulb at that point? If merely an incrustation around a rod, why is it that the rod is not equally incrustated throughout its entire length? Fig. 10 is not an exceptional example, there are others precisely similar, lying close by it in the same section. If this be an instance of capricious incrustation, we need hardly be surprised at it, when we consider the singular way in which we sometimes find chlorite investing one particular face of a quartz crystal in preference to the others. Probably, however, there is no caprice in nature, and phenomena

of this class may be governed by laws or brought about by conditions of which we are yet ignorant. It may be that Fig. 10 represents an originally spherical cavity, around which granular matter segregated, and that, from pressure, the spherical cavity has become elongated and has been protruded through the granular envelope as a straight cylinder. Figs. 9, 13 and 14 are straight filiform cylinders, which have this peculiarity, that they appear invariably to terminate in little nodes of granular matter.\* In Fig. 9 this granular matter either lies within or incrusts the cylinder. Are these nodes of granular matter discharges which have taken place from the ends of the cylinders? (if so, the cylinders are hollow)—or are they merely segregations which have formed on the ends of the rods? I submit these questions to the members of this Society, in the hope that they may be able to solve them.

Having now described these structures, it may be well to sum up the conclusions to be derived from them.

i. That the cylindrical processes extruded from the spherulitic bands in the obsidian of Lipari are solid rods of glass.

ii. That the spherules in this obsidian have resulted from the development of imperfect crystallization around minute foreign bodies, such as granules of magnetite &c., causing devitrification of the otherwise clear glass of the obsidian.

iii. That upon the contraction of this cryptocrystalline mass pressure was exerted upon small lacunæ of molten glass which were enveloped in it, and that fissures, produced in the outer crust of the spherulitic bands by the same contractile force, afforded channels of egress for this still fluid matter which after extrusion rapidly solidified.

iv. That the main glassy magma of the obsidian solidified last, but that the interval which elapsed between crystallization around nuclei, extrusion of glass rods, and solidification of the magma, was a very brief one.

v. That in the crystal of leucite described, there are structures which bear some analogy to those in the spherulitic obsidian.

vi. That the zoned spheroids in perlite are never, so far as I have ascertained, traversed by any fissures of even microscopic importance, but that, on the contrary, the spheroids always lie between these planes of fission.

vii. That the foregoing fact indicates a close relationship between this structure and the spheroidal structure sometimes seen in basalt, and that the two structures are probably due to the same cause.

\* So much has already been done by Vom Rath, Wedding, Zirkel, Des Cloiseaux, and others, in the examination of leucite, that it is quite possible that they may have observed similar structures; but of this I have seen no record.

One or two analyses of obsidian and leucite are appended, together with a few remarks thereon.

## ANALYSIS OF OBSIDIAN FROM LIPARI.

Abich, Vulk. Ersch., 1841, 62 and 84.

Silica .. .. .	74·05
Alumina .. .. .	12·97
Sesquioxide of iron .. .. .	2·73
Protoxide of iron .. .. .	—
Lime .. .. .	0·12
Magnesia .. .. .	0·28
Potash .. .. .	5·11
Soda .. .. .	3·88
Water and loss .. .. .	0·22
Chlorine .. .. .	0·31
	99·67

Although this analysis indicates that protoxide of iron is absent, yet one of an Indian obsidian, by Damour, shows 10·52 of the protoxide, but an absence of sesquioxide of iron.

When we consider that the protoxide of iron present in magnetite does not amount to more than about 30 per cent., and when we also consider that the crystals in the spherulitic obsidian from Lipari are partly altered or entirely altered into peroxide, either as hematite or limonite, we need not be surprised that the above analysis yields no protoxide of iron; and even if the magnetite were only slightly decomposed, its sparse dissemination in this rock would render the presence of protoxide of iron merely discernible in traces.

## ANALYSES OF LEUCITE FROM VESUVIUS.

	Klaproth.	Bischof.
Silica .. .. .	53·75	57·84
Alumina .. .. .	24·62	22·85
Lime .. .. .	—	0·2
Soda .. .. .	—	6·04
Potash .. .. .	21·35	12·45
Sesquioxide of iron .. .. .	—	0·14
Water .. .. .	—	0·59

Comparing these with the foregoing analysis of obsidian, it will be seen that the chief constituents of leucite and of obsidian are the same, but that the mineral and the rock vary somewhat in their percentage composition. Surely this identity of qualitative composition may to some extent account for the similarity which appears to exist between the structures described in this paper.

Before we finally quit this subject, let me once more direct your attention to the section of spherulitic obsidian. To my mind, we have here not merely a microscopic section, but a geological section of considerable significance. Let us suppose that the cortical zone of our spherulitic band is about 25 miles in thickness;



let us suppose that the underlying cryptocrystalline layer represents a mass of granite or other rock matter, once in a state of fusion, and which upon solidification shrank nearly 10 per cent. of its original bulk, as Bischof has shown that trachytic rocks do in passing from a vitreous to a crystalline state; let us also imagine that the little lacunæ of molten vitreous matter enveloped within this cryptocrystalline mass represent reservoirs of molten matter of considerable size, and that the glass rods extruded through the cortical portion of the spherulitic crust are dykes, which have been forced through pre-existing fissures by the contractile force of matter passing from the molten to the solid state; and we have here a somewhat correct rendering, I believe, of the way in which many great geological phenomena have taken place. Nature makes no difference between the most colossal and the most minute portions of her work. The contraction which takes place upon the solidification of a cubic inch of rock from the molten state is but a fraction, which if multiplied, will give the contraction of cubic miles of similar rock solidifying under like circumstances. The cubic inch is but the cubic mile in miniature, and we may even hold within our hands a small fragment of stone whose minute structure represents more truly than books can tell, or than diagrams can depict, the nature of some of those changes which are ever going on beneath our feet; of which, indeed, we should know but little, save for volcanic eruptions and those hardened weather-beaten wrecks of once deep-seated molten masses of rock, which are now exposed by denudation and within the reach of our hammers.

---

IV.—*On the Aperture of Object-glasses.* By F. H. WENHAM.

THE number of degrees that include a pencil of light radiating from one single point from the focus of a microscope object-glass, represents the true angle of aperture.

In order to obtain accurate results, the light indicating the admitted degrees should be confined to a mere point or line situated in that focus.

In the diagram the angles are the result of ascertained dimensions from a known immersion object-glass, as follows:—Acting diameter of front lens,  $\cdot 033$ ; focal distance from the front surface,  $\cdot 025$ , with a width of field of  $\cdot 020$ , or  $\frac{1}{50}$  inch. With correction adjusted, the resulting angle from central focal point is  $66\frac{1}{2}^\circ$ , each ray giving a distinct image. In order to determine the direction of the outer rays by the usual sector method, a narrow slit must be set in the focus: the extreme light of the true aperture will pass through from *a*.

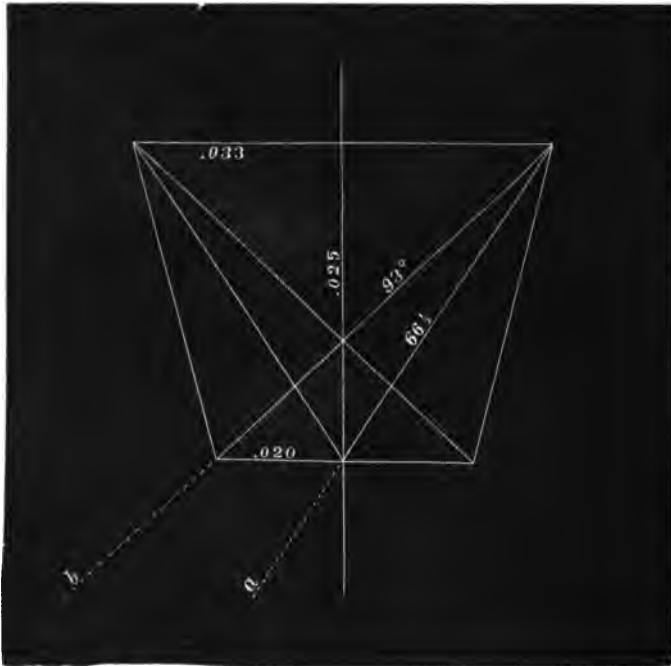

Let the slit now be opened out to  $\frac{1}{50}$  of an inch, so as to admit the effective oblique pencils embracing the entire field of view. Light will then enter from direction *b*. This ray will also show a distinct image, and an aperture of  $93^\circ$  will now be indicated instead

of the former  $66\frac{1}{2}$ . This excess of angle is a false quantity, because it does not come as a radiant from one single position in the axial focal point, but from other lateral rays of the marginal foci.

From this it may be inferred that unless precautions have been taken to exclude these lateral pencils, all measurements for ascertaining large apertures have hitherto been erroneous, and far in excess of the true pencil from a single radiant point; and this source of error will exist from the same cause, whether the measurement is taken by means of the usual convenient sector, or what may be termed the telescope method, of obtaining distinct distant images with a suitable eye-piece arrangement.

I disclaim invidious intentions in putting forth the expression, that the apertures of high-power object-glasses published in the lists of opticians are all wrong, and shall not quote any particular one as an example. If this is a scientific fact, let it be fairly discussed as such, without rancour or personality. The question is a simple one, and I cannot at present see that I am in error in a theory clearly proved by point of fact measurement.

The result may always be verified by the measurement of the focal distance (suitably corrected by the adjustment) and size of the working portion of the front lens, through which rays are admitted. Many will be surprised to find how small this portion is. In high powers it may be defined by screwing the object-glass in the place of the achromatic condenser, and the diameter of the spot measured with a micrometer, used with a low power. The front of the object-glass should have a drop of milk dried upon it to serve as a screen, or if the lens is flush with the setting, a piece of thin covering glass, greyed on one side, may be laid upon it, by means of which the proper light area can be determined having a definite margin.

---

V.—*On Zeiss'  $\frac{1}{5}$ th Immersion.* By W. J. HICKIE, M.A.

ABOUT the 18th of last October I obtained from Zeiss, of Jena, one of his  $\frac{1}{5}$ ths (No. 3 immersion), and during the first week in January the same maker forwarded two others, which he had completed only a few days before. On the evening of the same day all three were submitted to a trial of their capabilities. In the account I am about to give, I shall indicate the three  $\frac{1}{5}$ ths then examined by the letters A, B, C, where A denotes the objective first sent, while those sent in January are denoted by the letters B and C. As A had been in constant use for more than two months, I had had ample opportunity of making myself acquainted with all the peculiarities of this description of lens, as also with the

exact adjustment of the correction-screw required for a considerable number of the most trying tests. Having carefully compared these glasses, one with another, and likewise with Seibert's  $\frac{1}{4}$ th and Schieck's (so-called)  $\frac{1}{2}$ th, both immersions, I left off with a strong impression that the one I have called C was markedly superior to the other two, reserving the more rigid scrutiny for the following morning. As my habit is, when I have any task of this kind requiring more than ordinary carefulness, to work during the morning hours, and in a darkened room, it gave rise in this instance to a somewhat curious accident. Having arranged the lenses on a sideboard, and, as I thought, in the order in which I have named them, i. e. A, B, C, I renewed the examination of the preceding evening, but this time with the utmost care and exactness. On this occasion, however, to my great disgust, the decidedly best glass appeared to be B; and repeated trials only made its superiority more and more evident. Unwilling to believe that I could have been so maladroit the night before in a matter so straightforward as this, I proceeded to light a candle, and the mystery was solved at once. The glass I had taken up second on each occasion turned out to be C, which had somehow got placed second in order instead of third. As a matter of course, I tried them all again the morning after that; but the result remained the same, and C again proved itself to be the best glass all through. A came next in order of merit, and then, but at a considerable interval, B. It is therefore of C that I shall have to speak in this present paper, as the other two passed immediately afterwards into other hands. I may add, that the maker had himself compared them very carefully, and had been unable, as he declared to me, to detect any difference whatever. Before proceeding further, I will mention briefly the most salient features of this class of objective. The workmanship is conspicuous above all German objectives which I have seen for its extreme neatness, and may be examined all over with a hand-magnifier. There is no extravagant disparity between the breadth of the front lens and the breadth of the hindermost lens; upon which point I shall have something to say later on. Its working distance is remarkably great. But this is characteristic of all Zeiss' objectives. It has abundance of light, even with deep eye-pieces. This C now in my possession bears Ross' E eye-piece, with very little ill effect beyond becoming more difficult to manipulate. It also has complete flatness of field, and is wondrously sensitive to the slightest change of the correction-screw. The following instance will suffice to show this. On *Stauroneis spicula*, when placed vertical, and with the correction-screw set at  $11\frac{1}{2}$ , the transverse striæ are altogether invisible; but when the correction-screw is at  $12\frac{1}{2}$ , the same striæ are brought into view with perfect clearness! The screw-collar, instead of moving the front lens, as

is usually the case, moves the hindermost combination; in which arrangement there are certain advantages: it decentres the combinations much less, as is plainly apparent when this species of objective is compared with objectives on the old plan; the object also remains in sight while the adjustment is being altered, and there is at the same time less danger of smashing the covering glass of the slide. It is also well seen how carefully it has been corrected generally, and through all the divisions of the adjustment; from 5 to 16 inclusive; and that even at 15,—and I have only two slides (duplicates) that require so extravagant an adjustment,—its definition is both clear and beautiful. Beyond that it begins to show a little colour. This range, however, is amply sufficient for all reasonable purposes.

I must not omit to mention that certain mechanical alterations have been introduced into his objectives of this year, which did not appear in his earlier issues. The figures and division-lines connected with the correction-screw have been enlarged in size, to suit those who work by lamplight. In his earlier objectives these were so minute, as to make it often a difficult task to discover what was the precise adjustment one had fixed upon as best suited for the particular object under examination. The part containing the figuring and correction-screw has been slightly depressed, so as to keep it more out of the way of one's fingers; and the screw-collar itself has been made to move more stiffly. In his older objectives this part was sometimes so loose, that the proper adjustment often got shifted in handling, which made the glass appear to work badly. These alterations I cannot but regard as improvements, the more so as they were introduced at my suggestion.

I am here reminded of certain recent statements respecting the magnification of Zeiss' objectives, which seem to require some notice. Dr. Griffin\* states the magnification of Zeiss'  $\frac{1}{8}$  inch, with a B eye-piece, to be  $\times 640$ , and the magnification of his  $\frac{1}{4}$  inch (dry), with the same eye-piece, to be  $\times 875$ ; whereas, if we turn to Zeiss' catalogue, we find the magnification of the  $\frac{1}{8}$ th, with the second eye-piece, set down at  $\times 330$ , and that of his dry  $\frac{1}{4}$ th set down at  $\times 500$ . So, again, one writer in the 'M. M. J.' states the initial magnification of Zeiss'  $\frac{1}{8}$  inch to be  $\times 1250$ , and is contradicted by another, who appeals to Zeiss' own catalogue in proof that its initial magnification is only  $\times 680$ . In both cases

\* 'M. M. J.' No. lxxxvi., p. 96.

† I am sure so dispassionate a writer as Dr. Griffin will excuse me for reminding him, that to compare a dry lens with an immersion lens, is not usually considered a fair proceeding; and that he would have done better to have made the comparison with Zeiss' No. 2 immersion ( $\frac{1}{4}$  inch): not that I expect the result would have been much different, if the  $\frac{1}{8}$ th had been matched against so unique a glass as Powell and Lealand's new  $\frac{1}{8}$  inch, but it would have been a fairer course to adopt.

the statement has been made in good faith, and the contrariety is more seeming than real. Magnification is the product of objective, length of tube, and focal length of eye-piece. Now, Zeiss' figures are based on a length of tube of only 6 inches (while the length in England is about 10 inches), and on a focal length of eye-piece somewhat more than 2 inches, while our A eye-piece is, I believe, about  $1\frac{1}{2}$  inch focal length.

One quality in this glass (designated as C) which attracted my notice very strongly is its extraordinary resolving power. Its "grip" of an object is something enormous. And, as regards its definition, I may here briefly say, that I am perfectly contented with it; which is saying a good deal; as few are so hard to satisfy in this respect. This I infer from having observed the (in my opinion) very moderate performance which has satisfied my microscopical friends. Indeed, I have often been called upon to admire what (in my own work) I should call a failure. In this connection, a very singular remark is put forward by Otto Müller: \* "The resolving power of Zeiss' objectives is nothing specially great. On the other hand, their definition is surpassed by none of the objectives I have examined, and only equalled by few: the clearness and repose of the picture is a perfect pattern."

While accepting Müller's happily-chosen words "Klarheit" and "Ruhe," as exactly conveying my impression of the performance of my own glass (C), under which the object appears, as I have heard it described, like a sunlit landscape, with all the details vividly delineated, and the edge of the striæ, to the outermost margin, as sharp as a knife, I consider the former sentence so singularly in conflict with fact, that I must confess my inability to understand it as having been written by him, unless I am at liberty to suppose that he wanted to see how facts look when turned topsyturvy. Here in this country, if anyone were asked to mention the most noticeable feature in Zeiss' objectives, he would unhesitatingly single out precisely this resolving power, as the one that struck him most. Or may Müller's remark find its explanation in the fact, that he knew only Zeiss' older issues? He himself adds in his Preface: "I ought to mention further, that Zeiss' objectives have in these latest times [i. e. subsequently to the year 1870] been considerably improved, in consequence of which the results I have recorded no longer correspond to the present standard of performance of Zeiss' objectives." I notice also that his list mentions no higher power of Zeiss' than his  $\frac{1}{4}$  inch (dry). Some, indeed, among ourselves profess to have detected in Zeiss' objectives a lower scale of definition when compared with those of Hartnack; but, as they omit to mention what lenses of each maker were compared, the remark need not detain us. On one occasion I spent

\* 'Modern Objectives Compared,' p. 4.

the better part of a long summer's day at Hartnack's establishment in Potsdam, and that particular superiority in definition was just what I failed to discover! *Chacun a son gout*. But it is of this definition, and its supposed dependence on perfect centering, that I now wish to speak.

The popular persuasion with regard to definition would seem to be, that an objective's ability to bear deep eye-piecing is a sure proof of good definition; and, *vice versa*, that good definition is a sure proof of its ability to bear deep eye-piecing; and, that failure in these respects is a sure proof of bad centering; and this is the belief of many, of whose opinions I may not speak otherwise than with respect.

It may be briefly formulated as follows: "There can be no more certain test of good definition \* than that a glass bear deep eye-pieces exceedingly well."

These I believe to be the prevalent views with respect to the intimate connection between imperfect centering and imperfect definition; so that it becomes an interesting point to inquire "What are the real effects of bad centering?"

Let me first give an illustration. I have in my possession one of Gundlach's earliest  $\frac{1}{8}$ ths, brought out when he had his reputation still to make, the definition of which (with a low eye-piece) has always been greatly admired. Now, according to the above theory, this glass ought, by virtue of its excellent definition, to bear deep eye-piecing extremely well; whereas it breaks down utterly even under the light burden of a C eye-piece. Nor will the logic of results be bettered, if we say, that the inability of this glass to bear a C eye-piece is a plain proof that it can have no pretensions whatever to fine definition; for "facts are stubborn chieils, and winna ding."

If definition were possible only under the condition of absolutely perfect centering, then definition would be something still unknown to us; for absolute perfection in this respect is a physical impossibility.

Nägeli and Schwendener † have gone into this matter at some length.

They remark: "With regard to perfect centering, the highest that can be attained by the optician in this direction is at best only an approximation; and it is especially in the stronger objectives that he comes farther short of perfection."

"According to common opinion, exact centering is the condition of aplanatism; and this is the view taken by Harting and Mohl; and yet it is contradicted both by theory and observation."

\* Dr. Branwell expresses himself ('M. M. J.,' lxxxv., p. 43) more cautiously: "Deep eye-piecing is, above all, the surest test of correction."

† 'Das Mikroskop,' p. 69.



"Let us then inquire what will be the effect of a slight displacement of the combinations, whereby these, though remaining in the same plane, are pushed aside laterally in any direction."

The reader will see on pp. 70-74 of the work referred to how the editors have carried out their demonstration.

They further remark: "With every increase of displacement a corresponding marginal portion of the object is effaced, until at length the entire margin suffers more or less, leaving only a central portion of the field still retaining its original clearness, which portion, however, may take any eccentric position."

Their final summing up is: "That imperfect centering does, indeed, exert an injurious effect upon the optical image, but that this injurious effect limits itself (if we except the case where the axes of the combinations are not coincident with the axis of the tube), to the margin of the field, and only reaches the centre when the defects of centering are abnormally excessive."

Therefore the effects of imperfect centering are "to limit the area of definition," not to materially affect its absolute quality.

But this perfect centering is the product of several factors, and depends upon the fulfilment of more conditions than one. Granted that the axes of all the combinations are exactly coincident, there will still remain the exact coincidence of these with the axis of the tube,—which may be affected by the form of the tube itself, or even by the screw of the adapters,—and next, the coincidence of all the above with the axis of the eye-piece employed,—which latter, again, may be affected by looseness of fit or indifferent workmanship.

It may, indeed, happen that displacement in one direction is balanced by displacement in another direction; but these are elements that cannot generally be taken into account. Where the second defect comes into operation the injurious effects increase proportionately with the lengthening of the tube. As this defect sets the optical axes of the combinations at a slight angle with the axis of the tube, its immediate result is to introduce "want of parallelism," which is infinitely more destructive of good definition than imperfect centering. Anyone may demonstrate this to himself by looking at an object with a hand-magnifier, and holding the instrument slightly tilted. It will be noticed that I have omitted a case of possible occurrence; that is, where the lenses themselves are tilted in the setting. This, however, is not what is commonly included in the popular idea of "bad centering," but approximates to "want of parallelism." What is tested, then, by deep eye-piecing is "want of parallelism" *plus* chromatic and spherical aberration. Nägeli and Schwendener (p. 139) remark, in reference to this, that "coarse, blurred outlines, and coloured rims, which do not belong to the object, invariably point to defective correction of chromatic and spherical aberration;" and that "defective centering is betrayed

by the shifting position of the object when the objective is turned round" (p. 163). This operation, however, as it depends for its success upon the precision of the brasswork and the accuracy of the screw of the adapters, is seldom to be relied on. But the common practice of turning round the eye-piece in the tube is altogether illusory.

These considerations have suggested to me that possibly, where a foreign objective is tested on a microscope for which it was not constructed, and gets suspected of imperfect centering, the blame may be more justly apportioned between the maker of the microscope and the maker of the adapter. The chances, then, of perfect centering, as the phrase is popularly understood, are something infinitesimally small; and the generality of French and German opticians do not seem to distress themselves to any great extent about its attainment. Their *modus operandi* is pretty much as follows:—The back combinations are fixtures, put together and placed as fairly as is compatible with a moderate expenditure of labour. The workman then addresses himself to what he regards as the real business of the day, that is, to "marrying lenses," as he calls it. In other words, he tries on front after front, taken almost at random out of a great number, till he hits upon that one which exactly accommodates itself to the previous combinations, these fronts being, as an optician expressed himself to me, "made in bushels; yes, sir; made in bushels by girls." I could give, if it were desirable to do so, a goodly list of French and German opticians who follow this facile plan of manufacturing "first-class objectives." On the other hand, I could only mention two with any confidence, who, to judge by their workmanship, appear to follow a better advised method, and these two are Zeiss and Seibert. Glasses made on the first plan are easily recognized. Let the intending purchaser only hold them up to the light, and he cannot fail to notice the enormous disproportion between the breadth of the front lens and the breadth of the hindermost lens. There is, of course, a trick in this. As spherical aberration turns upon the fact that the focus of the peripheral rays is always shorter\* than that of the central rays, which disparity increases, *pari passu*, with the distance from the axis,† it is quite conceivable that the adaptation of an extremely minute front lens to wide back combinations may shorten the labour of correction very considerably. Such glasses, when used with a low eye-piece, sometimes exhibit very brilliant definition; but then it is only within a certain limited range of the correction-screw. They will also generally be found, in spite of their good definition, to

\* Thus, if we divide the periphery into a number of zones, the rays of the outer zone will have a shorter focus than those of the next zone, and the rays of the second zone a shorter focus than those of the third zone. See Nägeli, *l. c.*

† Nägeli and Schwendener, p. 43.

break down under deep eye-pieces, which popular theory says they ought not to do, and are further characterized by having almost no working distance, while their real magnification is always vastly below the nominal amount.

I propose to give now a tabular statement of the estimated performance of the three lenses I have mentioned; namely, Zeiss'  $\frac{1}{8}$  inch (C), Seibert's  $\frac{1}{8}$  inch, and Schieck's  $\frac{1}{10}$  inch. My manner of procedure has been as follows: I have taken 1000 as the highest number of marks that could be assigned to any objective for its performance, and have made my estimate in each case with this number as the maximum. In some instances I have given the average of three different trials.

<i>Stauroneis spicula</i> (horizontal).		
OBJECTIVES COMPARED.		MARKS.
Zeiss' $\frac{1}{8}$ inch	.. .. .	900
Seibert's $\frac{1}{8}$ inch	.. .. .	730
Schieck's $\frac{1}{10}$ inch	.. .. .	650
<i>Stauroneis spicula</i> (vertical).		
Zeiss' $\frac{1}{8}$ inch	.. .. .	600
Seibert's $\frac{1}{8}$ inch	.. .. .	0
Schieck's $\frac{1}{10}$ inch	.. .. .	0
<i>Frustulia Saxonica</i> (transverse lines).		
Zeiss' $\frac{1}{8}$ inch	.. .. .	970
Seibert's $\frac{1}{8}$ inch	.. .. .	450
Schieck's $\frac{1}{10}$ inch	.. .. .	800
<i>Frustulia Saxonica</i> (longitudinal lines).		
Zeiss' $\frac{1}{8}$ inch	.. .. .	800
Seibert's $\frac{1}{8}$ inch	.. .. .	200
Schieck's $\frac{1}{10}$ inch	.. .. .	430
<i>Navicula crassinervis</i> A (transverse lines).		
Zeiss' $\frac{1}{8}$ inch	.. .. .	950
Seibert's $\frac{1}{8}$ inch	.. .. .	750
Schieck's $\frac{1}{10}$ inch	.. .. .	700
<i>Navicula crassinervis</i> B (transverse lines).		
Zeiss' $\frac{1}{8}$ inch	.. .. .	960
Seibert's $\frac{1}{8}$ inch	.. .. .	600
Schieck's $\frac{1}{10}$ inch	.. .. .	520

Two of these were examined, the second somewhat finer than the first.

*Amphipleura pellucida* (transverse lines).

Zeiss' $\frac{1}{8}$ inch	.. .. .	600
Seibert's $\frac{1}{8}$ inch	.. .. .	540
Schieck's $\frac{1}{10}$ inch	.. .. .	500

Lamplight was employed on each occasion.

One word here about testing objectives. I have repeatedly heard it asserted, that the only proper course to pursue is to try them all, whatever their number be, under conditions exactly the same; that is, on the same object and with precisely the same

kind of illumination; and at first sight such a course appears to recommend itself to the judgment of all. But it will require no great amount of consideration to convince any reasonable being that no method could be more unfair or more productive of false results. Every high power has its own peculiar idiosyncrasy, has its own particular way in which alone it can be induced to do its best; and the illumination which is admirably suited for one glass may be very unsuitable for another. Or are we to expect all objectives to do equally well under all possible conditions of illumination? for that is pretty much what it amounts to, seeing that almost every microscopist has his own pet mode of illumination. To take an instance from the objectives in my own possession: Schieck's (so-called)  $\frac{1}{10}$  inch immersion works best with an Abraham's prism, brought up as close as possible to the stage, the top edge of the prism being half an inch higher than the object, and set at a particular angle. Zeiss'  $\frac{1}{15}$ th (C) is at its best when the angle formed by a line drawn from the object and one drawn along the bar of the mirror is exactly two degrees less than a right angle; and it shows itself very sensitive to any departure from this precise arrangement. Seibert's  $\frac{1}{14}$ th, again, exhibits its best performance when the above-mentioned angle is some three degrees greater than a right angle. My plan therefore has been to find out under what conditions each lens performs best, and to let each be tried in its own way, and then to estimate the results: a troublesome plan, no doubt, but, as I think, the only fair one.

I may now briefly state what I have been able to do with this C lens.

(1) Resolved Möller's (so-called) *Nitzschia curvula* into dots, and that too with the greatest prominence.

(2) Resolved every three out of five frustules of *Amphipleura pellucida*.

(3) Resolved the transverse lines of *Stauroneis spicula*, with the frustule lying vertical; that is, with the lines in the same direction as the illumination.

The first, I dare say, does not amount to much; and the second, perhaps, is not more than people usually expect from a first-class objective; but that there are many glasses able to do the third, and with the same means, is what I shall believe—when I see them do it.

I wish also to have it distinctly understood, that by "resolved" I do not mean "a wheen o' skarts" dimly visible through a dirty mist, but a complete resolution.

In doing the second I employed a silver mirror, with bright sunlight modified by blue glass. For the first and third I had merely a Bockett lamp, with a silver mirror assisted by certain paper shutters.

On the evening of the 7th of March I also saw with this lens, clearly and distinctly, the *longitudinal* lines of *Nav. crassinervis*, for the first time in my life. Did the same again on the 13th.

It will be inferred from the prominent place I have given to *Stauroneis spicula* throughout this trial, that I attach very great value to it as a test for high powers. And such, indeed, is the case. Of its extreme flatness, which recommends it for use with objectives of the very finest and most delicate construction, I need say little. There are other specialities connected with it. While a good  $\frac{1}{8}$ th may be able to show the striæ pretty fairly, a still better  $\frac{1}{8}$ th will reveal still more; and the best glass now in existence will probably leave something, either in matter or degree, to be shown by the still better objectives which may be used by our aftercomers. Or to put it thus: if a person possess half-a-dozen  $\frac{1}{8}$ ths, such that the second surpass the first, and the third the second, and so on, each surpassing its predecessor by a specific degree of excellence, and he try them upon it in the ascending order, beginning with the lowest, he will hardly, when he has tried his last and best glass upon it, rise up with the persuasion that he has completely *exhausted* his test. To be sure, the same might be said, in a certain sense, of almost any test, but of none so truly, so emphatically as of the one here mentioned.

But after all it really does not matter very much what the particular test is, if the operator only observe these three conditions: (1) that the test employed be one that ought to be just within the capacity of the class of objective he is trying; (2) that the operator be sufficiently exacting as to what constitutes the best possible image; (3) that he recollect with sufficient keenness what that best possible image is.

---

#### Corrections in the President's Address.

By some unaccountable oversight, in copying out the data for calculating the number of molecules in liquid water, the factor expressing the specific gravity of the vapour of water was omitted, and afterwards overlooked. The number of atoms of a gas should

really be multiplied by  $\frac{2}{3} \times 770 \times \frac{1}{.6239} \times \frac{1}{3} = 617$ . But,

moreover, on reflecting on the relative reliability of the determinations by the various authors of the number of the atoms in gases, it appears that in taking the mean, greater weight ought to be allowed to that by Clerk-Maxwell, since founded on more recent and accurate data. If his results be considered to be equal in value to those of Stoney and Thomson combined, the mean would be

reduced to so nearly the same extent as the number of the molecules of liquid water is increased by the above-named correction, that the numbers given in the Address may be considered to be as good an approximation to the truth as can be determined in the present state of the question, and all the general conclusions need not be in any way modified.

In order to avoid any misunderstanding, it may however be well to give the corrected numbers, which are as follows:

The contraction of the vapour of water in condensing into a liquid should be to  $\frac{1}{1334}$ .

The number of atoms and molecules in a cubic  $\frac{1}{1000}$  inch should be—

In a gas .. .. .	6,000,000,000,000
In liquid water .. .. .	3,700,000,000,000,000
In horn .. .. .	65,000,000,000,000
In living albumen—	
Albumen .. .. .	17,000,000,000,000
Water in molecular combination ..	923,000,000,000,000
	<hr/>
	940,000,000,000,000
In a sphere of $\frac{1}{1000}$ inch diameter—	
Albumen .. .. .	10,000,000,000,000
Water in molecular combination ..	490,000,000,000,000
	<hr/>
	500,000,000,000,000

In the length of  $\frac{1}{80000}$  inch there would be about 2000 molecules of water and 500 of albumen, which were the numbers previously adopted, so that the general conclusions are not at all modified by the corrections.

## PROGRESS OF MICROSCOPICAL SCIENCE.

---

*The Development of Hæmatococcus lacustris.*—An account of researches upon this microscopic plant, and upon the foundations of a natural classification of the Chlorosporous Algæ, are just published by Rostafinski—lately a pupil of De Bary—in the ‘Memoirs of the Academy of Sciences of Cherbourg,’\* which are thus abstracted by Professor Asa Gray in ‘Silliman’s American Journal’:—The identity of Protococcus, Hæmatococcus, or *Chlamydicoccus nivalis* and *pluvialis* is made out; at least it is shown that the latter can live upon snow and ice, and that the development is identical. For the generic name of the Red-snow plant, &c., Agardh’s name of Hæmatococcus is preferred, on good grounds: the specific name adopted is *lacustris*, Girod-Chantrons having well investigated the plant and figured and described it, under the name of *Volvox lacustris*, so long ago as the end of the last and the beginning of the present century (1797, 1802). Hæmatococcus propagates by two kinds of zoospores; i. e. sometimes by large and ordinary ones, resulting from the division of the contents of the cell or plant into four daughter-cells, each of which is transformed into a zoospore of somewhat complicated structure; while other individuals transform their contents into about thirty-two microzoospores. The development of both kinds of zoospores into the plant has been observed by Rostafinski. The development is non-sexual. Velter’s supposed discovery of the copulation of the large zoospores is discredited and explained away. Rostafinski concludes that Hæmatococcus is devoid of sexual reproduction. Following up Decaisne’s early hint that the reproductive organs of Algæ should furnish the characters for their natural arrangement, he indicates the principal groups or tribes of the Chlorosporæ which have thus far been made out, by De Bary and others, with some reorganization. Thus, after the Conjugatæ, in which fecundation takes place by the conjunction of two immobile cells of the same value (i. e. with no distinction of male or female), he proposes to place a parallel tribe, Isosporeæ, in which there is a copulation of zoospores, the sex of which is equally indeterminate (Hydrodictyon, Botrydium, &c.). The third is Oophoræ of De Bary (Sphæroplea, Vaucheria, CEdogonium, &c., to which Rostafinski adds *Volvox* and *Eudorina*); here the fecundation is by antherozoids and oospores. And he is disposed to take Hæmatococcus as the type of a fourth tribe, Agameæ, propagating non-sexually by spores.

*New Colouring Agents in the Examination of the Tissues.*—In a memoir devoted to the subject of amyloid degeneration of the kidney, liver, and spleen, which appears in a recent part of the ‘Archives de Physiologie,’ M. Cornil, of La Charité, gives the results of his experiments with several new colouring matters. Two of these, according to the ‘Lancet,’ were methyl-anilin violets discovered by M. Lauth, the third was a violet discovered by M. Hoffmann, of Berlin. The

\* Tom. xix., pp. 137-154, 8vo, 1875.



preparations can be stained with these violets either when fresh or after being hardened in spirit (Müller's fluid or picric acid); and the colouring agents have this peculiarity, that certain tissues, as cartilage, decompose them into a violet-red and a blue-violet, each of which becomes fixed in **different elements of the tissue**; the hyaline matrix, for example, assuming a red colour, whilst the nuclei and cellules, as well as the cartilaginous capsules, become of a blue-violet tint. The normal tissues of the liver, kidney, and spleen, however, do not decompose the violets, but when amyloid degeneration is present, the degenerated and semi-transparent parts resembling colloid become of a violet-red, whilst the normal elements are tinted of a violet-blue, and thus a means equal, if not superior, to that of iodine, is afforded by which the changes may be followed.

## NOTES AND MEMORANDA.

**An Improved Method of Numbering Objectives.**—The 'American Journal of Microscopy'—a new venture—states that two methods have been hitherto in use for numbering objectives—that is to say, for expressing their focal value. The custom adopted on the continent of Europe is to use an arbitrary series of letters or numbers, the different series adopted by various makers having entirely independent values. In England and in this country, the general practice is to state the focal value of the objectives in parts of an inch; thus a  $\frac{1}{4}$ -inch objective is supposed to be equivalent to a simple lens of one-fourth of an inch focus. This is a very simple, obvious, and accurate method, provided the makers adhere strictly to it. But it frequently happens that a  $\frac{1}{4}$ th is more nearly a  $\frac{1}{5}$ th or  $\frac{1}{6}$ th than a  $\frac{1}{4}$ th. A celebrated so-called  $\frac{1}{10}$ th is in reality more nearly a  $\frac{1}{8}$ th, while a famous  $\frac{1}{8}$ th of a well-known English firm is rated by our best microscopists as a  $\frac{1}{7}$ th. Mr. George Wale (U.S.A.), whose objectives are deservedly attaining great favour, has adopted the system of marking his objectives and eye-pieces with their magnifying power, taken at the standard distance of ten inches. Thus a  $\frac{1}{4}$ th is rated at 40 diameters, and a  $\frac{1}{10}$ th at 120 diameters. Two important advantages result from this. In the first place, the owner of the microscope is enabled to calculate accurately the exact magnifying power of every combination of the different parts of his instrument; and secondly, objectives may in this way be *accurately* rated, which is sometimes difficult, or rather inconvenient, on the other systems. Thus it would be awkward to assign to a lens magnifying 113 diameters, its exact focal value, but 113 diameters is not a very unmanageable number.

**Best Cement with Glycerine.**—Mr. W. H. Walmsley, of Philadelphia, writes to 'Science Gossip' of February, to say that he has used glycerine for many years in the mounting of vegetable and insect preparations, and has very rarely lost a slide from leakage. "I have used every description of cement with which I am acquainted that

could be employed with such a medium, and have found the white zinc cement, when properly prepared, to be by all odds the most satisfactory, on account of the facility with which it can be used, and its permanence. I usually keep a supply of cells ready made, with one or more coats of the cement, according to the thickness of the specimen to be mounted. A thin coat of the zinc is then to be applied by means of the tin table, the cell filled with glycerine, and the object placed therein as usual; the cover is then applied at one edge to the ring of cement, and gently loosened until it touches all around its circumference, when, being slightly pressed, it will be found to adhere quite firmly. A delicate spring compress is then to be applied, to prevent possible displacement of the cover, and the whole slide thoroughly washed in cold water with a brush, to remove every trace of glycerine. Then remove the compressor, and replace upon the tin table, and apply a thin coat of the cement to the edge of the cover, to be repeated until the slide is finished. The same process is applicable to deep glass cells."

**A Growing Cell adapted for supplying Moist Air.**—A cell of this kind, which promises to be of use in experiments on living fungi, has just been described by Drs. Lewis and Cunningham in their recently published work on the fungus disease of India. It consists of an ordinary glass slide 3"  $\times$  1", with a ring of beeswax (softened by the addition of a little oil) pressed on its surface towards the middle. Intervening between the wax and slide—clamped by it—is a narrow slip of blotting-paper; and above the wax a thin cover-glass is placed with a drop of fluid containing the spore or germ to be watched. The preparation will now be hermetically sealed except at the spot where the blotting-paper is inserted, the latter serving as an excellent channel for the air and moisture necessary to the perfect growth of the object under cultivation. There is no danger of dust being introduced, and the gases which the nutritive fluid may generate can readily escape.

**New Formula Objectives of Seibert.**—The editor of the 'Cincinnati Medical News' says, in his February number, that "several months ago we noticed in the 'Medical News' an objective, No. 5 ( $\frac{1}{4}$ th) immersion made by Seibert, of Seibert and Krafft, of Germany. We spoke of it as a fine glass, comparing very favourably with the work of the best English makes. Quite recently we have received from the same firm two other objectives, a No. 5 and a No. 6 immersions, made on a new formula, either one of which is very superior to the No. 5 we before described. We have subjected them to the severest tests, and have always found their performance admirable. We do not like to make invidious comparisons, but we will state that in comparing them with a recent  $\frac{1}{10}$ th by R. and J. Beck, we invariably found their resolving power quite superior, and so markedly so as to preclude any doubt."

---

---

## CORRESPONDENCE.

[www.libtool.com.cn](http://www.libtool.com.cn)

## MR. WENHAM'S CRITICISM ON PROFESSOR KEITH'S DIAGRAM AND COMPUTATION.

*To the Editor of the 'Monthly Microscopical Journal.'*

ALEXANDRIA, VIRGINIA, January 15, 1876.

SIR,—It seems to me desirable to reply to some of Mr. Wenham's remarks\* in relation to my computation of the angular aperture of the Museum  $\frac{1}{10}$ th, lest his errors should prevent some from seeing the full force of the result.

With regard to Mr. Crisp's  $\frac{1}{8}$ th, it was perfectly immaterial to me which of the objectives, having the aperture ridiculed by Mr. Wenham, was taken up. And I am now perfectly willing to take up Mr. Crisp's, if anyone desires it, and have no doubt that it would also illustrate the same statement, viz. "that the so-called theoretical limit" to the amount of light that can pass out of glass into air, has nothing whatever to do with the aperture of immersion lenses.

My diagram, which Mr. Wenham dismisses in a sentence quoted by Mr. Mayall, jun., represents correctly (as stated in the papers accompanying it) the lenses of the Museum  $\frac{1}{10}$ th, an objective which is not known at the Museum to have been surpassed by any other of the same power. Mr. Wenham's guess, that it could not be focussed upon a dry object, is directly contrary to Dr. Woodward's statement in his accompanying paper,† viz. "it performs admirably as a dry lens." The diagram further represents the path of a ray of light, which is of course "drawn in accordance with the computed results." It however fails to satisfy Mr. Wenham for the very curious reason that it "suits the proposition," whatever that may mean. The result of the computation is sufficient evidence that the curves, distances, and refractive indices were correctly given by the maker, otherwise, the objective could not have been found free from spherical aberration. But in addition to this the lenses were unscrewed by Dr. Woodward and myself and the maker's elements verified by measurement, as far as it was possible to do so, before the computation was undertaken.

The fact that the diagram represents correctly the well-known Museum  $\frac{1}{10}$ th, the photographs taken by which have given such general satisfaction, adds interest to the paper. But if elements had been guessed out, free from spherical aberration, the force of the result would have been the same.

Mr. Wenham's attempt to fix the limit of mathematical computation is quite as amusing as his attempt to fix the limit of aperture. I can assure him that it is perfectly possible to compute the spherical aberration of any combination of lenses however complicated and with

\* 'M. M. J.,' Nov. 1874, p. 221.

† 'M. M. J.,' Sept. 1874, p. 127.

any degree of accuracy, and not only possible but not difficult. Mr. Wenham's remark is the more amusing in that it comes from one who professes to measure on paper the variation due to chromatic dispersion!

www.libtool.com.cn

Respectfully, &c.,

R. KEITH.

## NOTES ON PROF. RUPERT JONES'S MEMOIR ON THE VARIABILITY OF FORAMINIFERA.

To the Editor of the 'Monthly Microscopical Journal.'

YORKTOWN, SURREY, February 23, 1876.

DEAR SIR,—Permit me to point out a few *corrigenda* in my paper "On the Variability of Foraminifera," in the 'Monthly Microscopical Journal' for February, No. lxxxvi., p. 61, &c.

1. My friend, Mr. H. B. Brady, whose works are quoted in the memoir, reminds me that, with regard to *Squamulina*, described by Schultze as calcareous and pore-less, and arranged in the Table, at p. 89, as a "porcellaneous" form, Mr. H. J. Carter has referred two "arenaceous" species to this genus; one monothalamous or sub-multilocular, the other polythalamous. See his memoir "On Two New Species of the Foraminiferous Genus *Squamulina*," &c.\*

2. Mr. Brady also assures me that the quadriserial arrangement of the chambers in *Tetrataxis* (Table, p. 89) is not sufficient to distinguish it from *Valvulina*. He can only say that in the Carboniferous strata there are more quadriserial than triserial *Valvulina*, and *vice versa* in the Tertiary deposits and recent seas.

3. He adds that *Ellipsoidina* (see the Table, p. 90) has its nearest ally in *Chilostomella*, and both should closely follow *Polymorphina*, though almost as much related to *Bulimina*; and that *Allomorphina* goes with the first two in Reuss's group of the "Cryptostegia."

4. *Archæospharina* (in Table, p. 92) is now regarded by Dr. Dawson as being probably separated germ-like portions of the acervuline variety of *Eozoön*.†

5. *Errata et Addenda*. Page 62, line 34, for 18 read 20.

P. 65, first footnote, add Dr. Wallich also has figured a similar *Planorbulina* (?) with symmetrically perforated chamber-walls, in 'The North-Atlantic Sea-bed,' 1862, pl. 6, f. 20; and in his memoir entitled 'Deep-sea Researches on the Biology of Globigerina,' 1876, fig. 20.

P. 73, last line, for procure read produce.

P. 87, third line from bottom, for 2-6 read 2-5.

P. 88, line 8, for 7 read 6.

P. 89, line 32, for Gryroporella read Gyroporella.

Pp. 90 and 91, *Ataxophragmium* and *Plecanium* occur twice over on account of the double character (both sandy and smooth) of the types to which they belong.

\* 'Ann. Mag. Nat. Hist.,' ser. 4, vol. v., pp. 309-326, pl. 4 and 5.

† See 'Quart. Journ. Geol. Soc.,' vol. xxxii., p. 73.

Lastly, observing that varieties among Foraminifera are of equal value to species and even genera in higher animals, as far as concerns bathymetrical and geographical distribution, I would refer the reader to Dr. Carpenter's "Researches on the Foraminifera," 'Phil. Trans.' for 1860, p. 584, &c., for valuable remarks on the Variability and Persistence of Foraminifera. See also Lyell's 'Antiquity of Man,' 4th edit., p. 494, &c.

I am yours truly,

T. RUPERT JONES.

P.S.—With regard to the spicular contents of *Carpenteria* and *Polytrema*, mentioned at p. 65 (fifth line), Mr. H. J. Carter has convinced himself by extended and close observation that the Sponge spicules found in these Foraminifera have been chiefly taken in by the sarcode during life, together with diatoms and other organic particles. In some instances the broken walls have allowed the entrance of such strange bodies into the cavities; and sometimes parasitic Sponges wholly or partially invest the shells. Occasionally the spicules are incorporated in the wall-tissue. Lastly, Mr. Carter recognizes a close similarity in structure and features between *Carpenteria* and *Polytrema*, leading him to combine the two under the latter (older) name. See his memoir "On the *Polytremata*," &c., 'Ann. Mag. N. H.,' ser. 4, vol. xvii., March 1876, p. 185, &c., pl. 13.—T. R. J., March 11, 1876.

#### CHROMATIC AND SPHERICAL ABERRATION.

To the Editor of the 'Monthly Microscopical Journal.'

16, FITZROY SQUARE, W., March 10, 1876.

SIR,—In p. 232 of your November issue, Dr. Royston-Pigott states that the spherical aberration of a monochromatic ray "is for convenience called chromatic aberration," of which I maintain a *monochromatic* ray to be destitute.

In p. 129 of your last issue he admits that "in standard works on Optics, chromatic aberration and spherical are treated for convenience as distinct things." When we are in possession of Dr. Royston-Pigott's "standard work on Optics," in which, I presume, these optical conditions will be treated as identical, we shall be enabled to form an opinion on the relative convenience of these very opposite modes of treating the subject.

In your February number he expresses a hope that I and others who have addressed to you our dissent from his opinions, will on further reflection regret having done so. I can only assure him that I do not, nor am I likely to, regret this or any other steps that I may have taken in furtherance of the logical accuracy of scientific nomenclature.

I remain yours faithfully,

CHAS. BROOKE.

## CHROMATIC AND SPHERICAL ABERRATION.

To the Editor of the 'Monthly Microscopical Journal.'

[www.libtool.com.cn](http://www.libtool.com.cn)

CHISLEHURST, March 15, 1876.

SIR,—May I, as a very old member of the Microscopical Society, be permitted a few remarks on the two papers by Dr. Royston-Pigott which appeared in the 'M. M. J.,' No. lxxxiii., p. 232, and No. lxxxvii., p. 128, which in my opinion are highly pernicious, as being calculated to produce in the minds of the uninformed a hopeless confusion of ideas between two things utterly distinct, and which the author himself incidentally shows to be distinct in the course of his illustrations.

I would premise, that in mathematical attainments I do not presume for one moment to compare myself with this gentleman; but as a veteran worker with the microscope, who believes that an intimate acquaintance with the theoretical and practical construction of all the optical parts of the instrument is a *necessity* to an accurate observer, I have for over five-and-thirty years studied the science of optics with a special view to its practical application; and I trust that I may, without offence, express my strong dissent from the conclusions at which Dr. Royston-Pigott appears to have arrived, and to express my conviction that, from some unexplained cause, he applies another meaning to the term "chromatic aberration" than that generally accepted.

At p. 131, No. lxxxvii., of the 'M. M. J.,' some well-known experiments illustrative of chromatic and spherical aberrations are described; but oddly enough, instead of pointing out that the differing positions of the foci of the *red* and *violet* images of the sun, as formed by the marginal rays only, or by the central rays only, illustrate the chromatic aberration, and *nothing else*, the author dilates upon the fact, that the different positions of the foci for the *red* image of the sun when formed by the marginal or central part of the lens respectively, and the same with the violet image, show, that both the red and violet rays are subject to spherical aberration; and the foot-note in p. 132 of the same number is to the same effect.

But this is a fact about which, so far as I know, there has never been any dispute. Of course the rays of light of all colours are *subject* to spherical aberration when transmitted through lenses with spherical surfaces; but that has nothing whatever to do with chromatic aberration, which arises solely from the various degrees of refrangibility of the differently coloured rays. In point of fact, *chromatic aberration* is due to the compound character of the light employed, and has no existence with homogeneous light; while *spherical aberration* is due only to the *form* of the lens employed, whether the light is simple or compound; and these facts are abundantly demonstrated by the experiments detailed by Dr. Royston-Pigott himself.

"Chromatic aberration" requires for its correction the use of at least two refracting media (besides the air) of varying dispersive powers, and cannot exist with monochromatic light. "Spherical aberration" *can* be corrected or balanced for monochromatic light

with two lenses of the same refracting medium, by combining a bi-convex and a meniscus lens, as shown by Herschel.

Lastly, a reflecting telescope has its principal reflector worked to a parabolic curve, to avoid the spherical aberration that would be introduced were the reflecting surface spherical; but though compound light is used, there is no chromatic aberration to correct, whether the reflecting surface is spherical or parabolic in its curve. How then these two errors can be regarded as "identical in character," is to me simply incomprehensible.

Dr. Royston-Pigott complains, and with reason, of the scant courtesy of tone in some of the correspondence which has appeared in this Journal upon optical questions; but surely he should not include in his condemnation the letter of our old friend Mr. Chas. Brooke which appeared in No. lxxxv., p. 45, in which I can perceive nothing but a temperate and legitimate protest against what the writer regards as erroneous doctrine upon a scientific matter.

I shall be very sorry if Dr. Royston-Pigott regards my letter in the same light, as nothing can be farther from my thoughts than offering him any offence; but unless adverse criticism of novel theories can be freely indulged, scientific progress must be impeded.

I am, Sir, your obedient servant,

GEO. SHADBOLT.

## PROCEEDINGS OF SOCIETIES.

### ROYAL MICROSCOPICAL SOCIETY.

KING'S COLLEGE, *March 1, 1876.*

H. C. Sorby, Esq., President, in the chair.

The minutes of the preceding meeting were read and confirmed.

A list of donations to the Society was read by the Secretary, and the thanks of the meeting were voted to the donors.

The Secretary said they had received a paper "On the Measurements of the Diatoms of Möller's Probe-Platten," by Professor Morley, which would be printed in the Journal. The paper was accompanied by a number of tables, copies of which had also been sent for distribution amongst the Fellows present.

Mr. W. N. Hartley, F.C.S., read a paper "On the Identification of Liquid Carbonic Acid in Mineral Cavities," illustrating the subject by drawings upon the slate, and by specimens exhibited under the microscopes in the room. Two specimens were so arranged that a jet of hot air could be impinged upon them whilst under observation, and the sudden vaporization and subsequent condensation of the liquid enclosed in the cavities was in this manner clearly demonstrated. An ingenious contrivance was also exhibited by means of which the critical point of a liquid could be readily determined.

The President felt sure that the Fellows would give a very hearty vote of thanks to Mr. Hartley for the very interesting paper which he had just read to them. He was very much gratified to find that



Mr. Butler's experiments led up to the same results as those which had been arrived at by Mr. Hartley. At the time his own experiments were made, it was not known that liquid carbonic acid occupied any place in the mineral world; but from the conclusive observations which had been made since that date, they could not now doubt its existence there as a natural product. Mr. Hartley had enjoyed the advantage of the experiments of Professor Andrews upon the subject, which of course he (the President) had not the opportunity of referring to at the time his own experiments were made. At the present time an observer knew exactly what to look for, and they knew very well how much more easy it was to find a thing when we knew just exactly what it was that we ought to look for. Some of the effects which had been mentioned by Mr. Hartley were very remarkable; the peculiar effect at the time of boiling was very so, but then it was so quickly done and the changes took place so rapidly that it was quite a matter of astonishment to anyone seeing the experiment for the first time. In sapphires he could never detect any water in the cavities; they appeared in all cases to be filled purely with carbonic acid; and he believed that it was a fact that the sapphire was always found in connection with limestone. Any gentleman who had not yet seen these effects would be very much surprised at them. In their bearing upon theoretical geology they were of course of very great importance.

Mr. Hartley said he had observed in the case of nearly all his specimens that the surface of the fluid in the cavities had a concave curvature, showing that the sides were wet, and thus indicating the presence of water as well as carbonic acid; but in the specimens of sapphire the curvature of the surface of the contained fluid was convex, and the sides seemed to be perfectly dry, from which he judged that the fluid in these instances was pure carbonic acid.

The President said that it gave him much pleasure to announce that Mr. Butler had kindly promised to exhibit his specimens at their approaching conversazione. Mr. Hartley also signified his willingness to exhibit his apparatus, &c., on that occasion.

Mr. Rutley mentioned that the President had referred to the circumstance of the sapphire being usually found in limestone; there was, however, an instance occurring in some mines in Carolina, U.S.A., in which corundum occurred in gneissic rock.

The President said that the cavities were very rare in the case of the ruby; Mr. Butler had only found one or two specimens containing liquid, out of many hundreds which he had examined.

The Secretary said they had received a paper from Mr. Dallinger, one of their Vice-Presidents, "On a New Arrangement for Illuminating and Centering with High Powers." The paper was too technical to be readily understood unless it were in the hands of every Fellow. Mr. Dallinger had found that the precise position of the lamp was of great importance as well as the exact centering of the illuminating apparatus, and he had devised a lamp for the purpose with a screw motion, by means of which the exact position required could be obtained. The paper without the diagrams would, he feared, be quite unintelligible to the meeting; it would therefore be "taken as read,"

and would be printed in the next number of the Journal, together with the illustrations.

The thanks of the Society were unanimously voted to Mr. Dallinger for his communication.

Mr. F. Rutley read a paper "On the Structure of certain Rocks—Obsidian and Leucite, with Notes on the Spheroidal Structure of Perlite." The paper was illustrated by a number of coloured diagrams and by specimens exhibited in the room.

The President felt sure it would be the pleasure of the Fellows to return their best thanks to Mr. Rutley for his paper, for papers of this kind were extremely rare, and were of great interest and value. Microscopists who did not know the wonderful things to be found in rocks, would be greatly astonished at what was to be seen there, if they would take up the examination as a study. Even in slags which had without any question been melted, they might find things which they would be sure to say at first sight were organic, and when they came to the study of the minute crystals found in some of these rocks, it was surprising to find how very little there appeared to be of the ordinary character of crystals about them. They would often meet with structures which were extremely curious, and suggested many of the ideas which they usually connected with living bodies. He mentioned this as showing that they should be very cautious in coming to conclusions upon mere resemblances. He quite agreed with Mr. Rutley that the structure of the cavities was very remarkable. He had not examined the Perlites, but fully agreed with Mr. Rutley that the facts were exceedingly curious, and that they represented on a small scale what went on in nature on a large one.

The Rev. T. W. Freckelton was introduced by the Secretary as a new Fellow, and formally admitted by the President.

The President reminded the Fellows of the Society that the conversazione to which reference had been made at the previous meeting would be held on the 21st of April, and asked that all would assist in bringing objects of interest on that occasion. The Council had formed themselves into a committee to carry out the arrangements, and they were very anxious to bring together a good collection of objects of real interest.

The proceedings then terminated, the meeting standing adjourned to April.

Donations to the Library since February 2, 1876 :

Nature. Weekly .. .. .	From
Athenæum. Weekly .. .. .	<i>The Editor.</i>
Society of Arts Journal .. .. .	<i>Ditto.</i>
Quarterly Journal of the Geological Society. No. 125 ..	<i>Society.</i>
Journal of the Linnean Society .. .. .	<i>Ditto.</i>
The Cincinnati Medical News.	<i>Ditto.</i>
Bulletin de la Société Botanique de France. Two parts ..	<i>Author.</i>
El Microscopio en Litología. Par Don Francisco Q. G. Rodriguez	
Dioptrica Nova: a Treatise of Dioptricks. In two parts.	
By William Molyneux, Esq., F.R.S. . . . .	<i>B. D. Jackson, Esq.</i>

Dr. Thomas Partridge was elected a Fellow of the Society.

WALTER W. REEVES,  
Assist.-Secretary.

## QUEKETT MICROSCOPICAL CLUB.

Ordinary Meeting, December 17, 1875.—Dr. Matthews, F.R.M.S., President, in the chair.

Mr. Ingpen gave a description of the various methods employed from time to time for measuring the angular apertures of objectives. Commencing with that of Mr. Lister, which was the only one in general use prior to 1854, he gave a detailed account of the improvements effected by Mr. Wenham, Mr. Gillett, Dr. Robinson, and others; and concluded with some remarks upon angular aperture generally, with reference to the various opinions held upon this somewhat vexed subject.

Ordinary Meeting, January 28, 1876.—Dr. Matthews, F.R.M.S., President, in the chair.

Mr. Ingpen described a portable binocular microscope recently constructed by Mr. Swift. This instrument not only packed in an extremely small space, but also comprised several contrivances of great convenience. The binocular body, when not in use, could be turned in front, so as to be quite out of the way. The rack was of sufficient range for the lowest powers. The stage was extremely thin, and had a countersunk rotating ring, into which an extra selenite or mica film could be introduced, or it could be used for the examination of diatoms, &c., by oblique light. The compound achromatic condenser was focussed by means of a diagonal slot instead of rack-work; and the analysing prism moved in a slot above the binocular prism, and was thus always ready for use. These and sundry other arrangements made the instrument very complete and effective as well as extremely portable.

Mr. T. Curties read a paper by Mr. Henry Davis, F.R.M.S., "On a Larval Cirripede," a specimen of which was found by him on a feather of a sea bird shot about 500 miles N.W. of the Cape of Good Hope. It was at first supposed to be the egg of a parasite, but closer examination proved it to be a crustacean, an advanced larval form of *Lepas pectinata*. The paper contained a minute description, and details of the development of this interesting Cirripede, and was illustrated by drawings and specimens.

Mr. A. Hammond read a paper "On a Comparison of the Metamorphoses of the Crane-fly and the Blow-fly," in which he endeavoured to show that the former insect forms an exception to the rule enunciated by Dr. Weismann, wherein he expresses his belief that "in all those insects in which the anterior larval segments are unprovided with appendages (legs) the head and thorax of the imago are entirely re-developed." Mr. Hammond stated his belief that in this insect the imaginal disks, if such they were entitled to be called, were to be regarded rather as invaginations of the newly forming pupa skin than as independent centres of growth, commencing in separate closed capsules. He described eight pairs of these disks as occurring in the crane-fly, and particularly adverted to the superior pro-thoracic disks as being concerned in the formation of corresponding appendages,

whose development, though arrested in the imago, was very conspicuous in the preceding pupal stage; and from thence passed to the corresponding disks and appendages in the blow-fly, to the observation of which he had been led by the study of the former insect. The disks in question, which Mr. Lowne had somewhat doubtfully located in front of the supra-oesophageal ganglia, were described as surrounding the anterior terminations of the tracheæ of the larva. After some allusion to the apparently anomalous situation of the posterior leg disks of the blow-fly, as being attached to the tracheæ instead of the nerve centres, as is the case with the anterior and intermediate legs, Mr. Hammond concluded by contrasting the mode of development of the tissues in the two insects; calling attention to the complete and sudden character of the changes in the blow-fly, as compared with the more gradual processes followed in the development of the crane-fly.

#### SOUTH LONDON MICROSCOPICAL AND NATURAL HISTORY CLUB.

An ordinary meeting of this club was held on October 19, 1875, at the Angell Town Institution, Brixton. Charles Stewart, Esq., M.R.C.S., F.L.S., presided.

An address was delivered by Mr. James Reeves, on "Oysters." The lecturer commenced by describing the oyster-beds, and then gave an account of the spawn of oysters. Tracing the growth of the young oyster from its birth, when it is lively and swims about the surface of the water, to the time when, as it becomes heavier, it sinks to the bottom of the sea, Mr. Reeves gave a long account of the various enemies of the oyster; the sea-anemone, the "borer," the dog-whelk, and the star-fish, attacking the oyster in turn. The various kinds of oysters were then described; "Natives," "Channel" oysters, "Jersey" oysters, and many other varieties. The Report of the Commissioners appointed to inquire into the oyster fisheries was then criticised, and the theory that oysters were rendered scarce by over-dredging was confuted. The important points—how to catch, how to keep, how to open, and how to eat oysters—were then considered; and various specimens of oysters were exhibited in illustration of the last two points.

A discussion ensued, in which Messrs. Stewart, Hovenden, and Reeves took part.

At the ordinary meeting held on November 16, a paper was read by Mr. G. F. Linney, of Croydon, on "Conchology." After describing the method of prosecuting the search for shells, and the necessary equipments, Mr. Linney gave an account of the method of killing the animals, cleansing the specimens, storing them, and arranging them for exhibition. The classification of the *Mollusca* was next considered, and the various families of the classes *Conchifera* and *Gasteropoda* described in detail. Mr. Linney then gave various instances of the peculiar localization of certain shells, and of the effect of heat, weather, &c., upon their growth. In conclusion, the microscopical examination of some of the animals was described, their

digestion and respiration being easily observed; and the *Zonites nitidulus* was mentioned as an especially good specimen.

An interesting discussion followed the reading of this paper, and the President then gave an account of the reproduction and development of snails. [www.libtool.com.cn](http://www.libtool.com.cn)

A meeting of the club was held on December 21, which was somewhat special, ladies being admitted, and a large number of microscopes exhibited. An address was delivered by William Carruthers, Esq., F.R.S., F.L.S., F.G.S., on "The Earliest Fruit Remains of the Earth." The lecturer restricted his remarks to the vegetation of the Palæozoic or primary rocks, and described in detail the gymnospermous plants found in these rocks, and also the coniferous trunks found in sandstone beds near Edinburgh, a specimen of which, 4 feet in diameter, and 40 feet in length, is preserved at the British Museum. Fruits found in the quartzose rocks at St. Etienne, near Paris, were also described; these belong to the Taxineous group of trees, and are allied to the fruit of the *Salisburia adiantumfolium*—a tree common in London, but a native of Japan. Passing now to the consideration of the cryptogamous plants found in the coal-measures, Mr. Carruthers described the cones which are the fruit of a tree called *Lepidodendron*, and compared them, by the aid of diagrams, with the *Lycopodium* and *Selaginella* of the present day. Other fossil cones were compared with the *Equisetum*, or horse-tails, to which they are allied in structure. The ferns found in the coal-measures were then described, and Mr. Carruthers alluded to his discovery of a specimen exhibiting the peculiar structure of the fruit. The fossil ferns were compared with the modern Polypody and the Tunbridge filmy fern. In conclusion, the lecturer gave an account of a fern found by Professor Edward Forbes in the Devonian rocks of Ireland, which agrees exactly with living ferns.

The address of Mr. Carruthers was throughout listened to with the closest attention; and at its close the audience displayed great interest in the various objects illustrative of the subject, which were arranged systematically and exhibited under the microscopes of the members.

---

[www.libtool.com.cn](http://www.libtool.com.cn)

www.libtool.com.cn

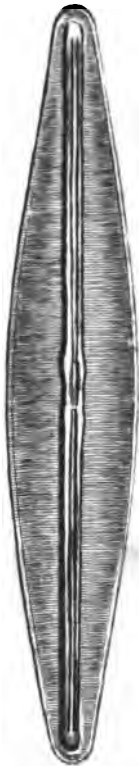

A  
*N. Rhomboides.*  
x 580

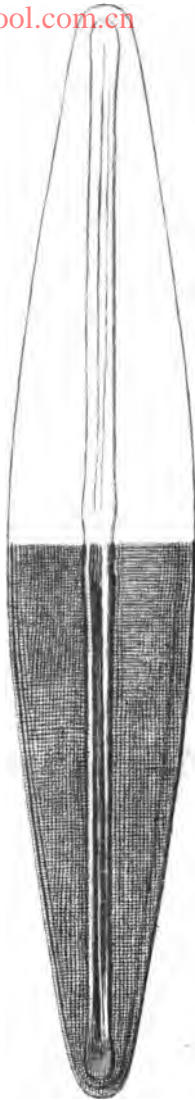

C  
*N. Rhomboides.*  
x 870



B  
*N. Rhomboides.*  
x 580



x  
*N. Crassinervis.*  
x 580

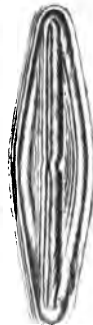

x  
*N. Crassinervis.*  
x 580



[www.libtool.com.cn](http://www.libtool.com.cn)

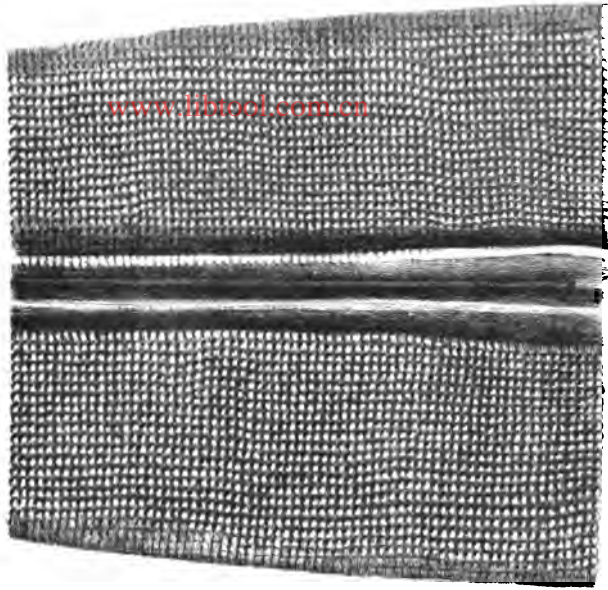

E  
*N. Rhomboides.*  
x 8700

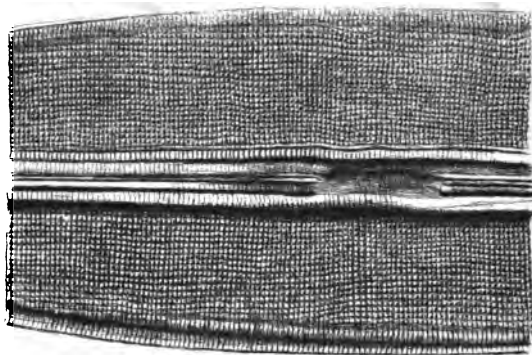

D  
*N. Rhomboides.*  
x 1550

THE  
MONTHLY MICROSCOPICAL JOURNAL.

www.libtool.com.cn

MAY 1, 1876.

---

I.—*Note on the Markings of Navicula Rhomboides.*

By Dr. J. J. WOODWARD, U. S. Army,

(Read before the ROYAL MICROSCOPICAL SOCIETY, April 5, 1876.)

PLATES CXXXV. AND CXXXVI.

MR. HICKIE'S reply to my "Note on the Markings of *Frustulia Saxonica*"\* was unfortunately crowded out of the February number of the Journal, and I will therefore postpone any discussion of the views I am informed he has expressed until I see his paper. I have, however, received through the politeness of Mr. John Mayall, jun., copies of Herr Seibert's photographs, which Mr. Hickie exhibited as photographs of *Frustulia Saxonica* at the meeting of the Royal Microscopical Society, January 5, 1876, and I desire to offer a few remarks with regard to them.

In the first place, I must compliment Herr Seibert on his success in photographing what he saw; and his willingness to exhibit the photographs is a proof of his sincerity. Next, I desire to point out the convenience and accuracy of photography for the purpose of such a discussion as this. Without it I should have been unable to form any definite opinion as to what Herr Seibert had seen. Lastly, I must express my conviction that the remark attributed to Mr. Mayall in the report of the proceedings of the meeting mentioned,† that the diatom photographed by Herr Seibert was "a coarse form of *Rhomboides*," is quite correct.

This conviction is forced upon me by a consideration of the distance of the striæ apart, in connection with the size and shape of the diatom as shown in Herr Seibert's photographs. These make the diatom four inches long. The length of *Frustulia Saxonica* varies from  $\cdot 0012$  to  $\cdot 0030$  of an inch. (On a slide labelled *Frustulia Saxonica*, loaned by Mr. Hickie to Mr. Mayall as authentic—to which I assented—and loaned by Mr. Mayall to me, I found none any longer than  $\cdot 003$  of an inch.) If, then, Herr Seibert has photographed even the coarsest of these forms, his pictures are taken with over thirteen hundred and thirty diameters. But his photograph of the transverse markings gives 110 lines to

\* 'Monthly Microscopical Journal,' Dec. 1875, p. 274.

† Ibid., Feb. 1876, p. 103.

the inch. The original diatom then must have had over 146 transverse striæ to the  $\frac{1}{1000}$  of an English inch, and it is not reflecting on their skill as microscopists to assert that neither Herr Seibert nor Mr. Hickie could have even glimpsed striæ so fine as this, for the objectives which would enable anyone to do so have yet to be constructed.

It is quite evident, then, that Herr Seibert must have photographed some diatom much larger than *Frustulia Saxonica*, and that this larger diatom was a coarse specimen of *Navicula Rhomboidea*, I hope to convince those who will examine the accompanying photographs marked A and B [or their representations in the accompanying Plates].

On the Möller's type-plate (specially arranged) belonging to the Army Medical Museum, there is a specimen of *Navicula Rhomboidea* .0069 of an inch long, with 60 "transverse striæ" (really rows of beads) to the  $\frac{1}{1000}$  of an inch. When this is photographed so as to give an image of the same size as the diatom photographed by Herr Seibert, it appears so similar to it in form, and, when the light is suitably managed, in the character and fineness of the striæ, as to leave no reasonable doubt that it is of the same species and very nearly of the same size.

In order to approximate as closely as possible to the conditions indicated by Herr Seibert's photographs, I used an immersion No. 9 of Hartnack, and throwing the light lengthwise to the frustule, obtained the photograph marked A, showing the transverse striæ. I intended to make my picture of the frustule the same size as Herr Seibert's; and, in fact, on my negative it is the same size, as on the print from his in my possession; but as prints spread more or less when rolled, and shrink sometimes when not rolled, of course the frustule on my negative is not *precisely* of the same size as on his, though it must be very nearly so. My negative proved to be magnified 580 diameters, and the striæ counted 103 to the inch on the negative—(on the paper prints they vary of course). Next, throwing the light transversely to the length of the scale I obtained the photograph marked B, which shows the longitudinal lines quite like those in Herr Seibert's second picture.

I think no candid observer who compares these pictures with Herr Seibert's, will hesitate to admit that the two diatoms represented are very similar frustules of the same species. The small difference in the number of striæ might have been somewhat reduced had I been able to make the diatom in my pictures of exactly the same size as that in Herr Seibert's; and the resemblance would have been still further increased if I had stopped out the background with some opaque paint, as he has done. Instead, I preferred to stop it out with tissue paper, which, while giving prominence to the central diatom, permits all the other objects in

the field to print. Among these objects are several other diatoms, of which the one indicated with a cross (thus  $\times$ ) is described by Möller, in the catalogue accompanying the Museum plate, as "*Navicula crassinervis*"; in its size, the character of its markings, and all essential points, it resembles the specimens of *Frustulia Saxonica*, which are represented as seen with a higher power in the photographs accompanying my former paper. A comparison of these pictures with those is therefore respectfully solicited.

Thus far to convince those who examine these pictures that I have really before me substantially what Herr Seibert's pictures represent. But I have next to observe that, even with the Continental lenses which I suppose that gentleman to have used, he ought to have been able both to see and to photograph the hemispherical heads which are the true markings of this diatom. I retract the error into which I fell when, misled by the imperfect descriptions of Mr. Hickie, I supposed the longitudinal lines photographed by Herr Seibert to be diffraction phenomena. They are merely the result of imperfect definition. I send herewith a photograph of the same frustule, marked C, magnified 870 diameters by the same Hartnack immersion 9. I have simply increased the distance from the object to the screen to gain the increased power, and taken a little more care with the adjustments than in the former picture. The true markings are, however, much more brilliantly shown by a good English or American immersion objective. I send herewith a photograph (marked D) of a part of the same frustule, magnified 1550 diam. by Powell and Lealand's immersion  $\frac{1}{16}$ th, without eye-piece; and another (marked E) of the same, magnified 2700 diameters by the same objective with eye-piece, which may serve to demonstrate the truth of this statement.

In conclusion, I may remark that while Mr. Hickie argues that there are valid distinctions between *F. Saxonica* and *N. crassinervis*, several gentlemen with whom I am acquainted go to the other extreme, and hold not only that there are none between these two, but even that there is none between them and *Navicula Rhomboides*. I prefer not to discuss either of these points at present; but may, perhaps, do so after I have read Mr. Hickie's paper.

---

II.—*Some Results of a Microscopical Study of the Belgian Plutonic Rocks.* By A. RÉNARD, S.J.

(Read before the ROYAL MICROSCOPICAL SOCIETY, April 5, 1876.)

PLATE CXXXVII.

THIS paper is a very brief and comprehensive statement of a few of the results obtained by applying the microscope to the study of some Belgian rocks; they are developed more at length in the *Mémoire* which I made together with the Prof. de la Vallée Poussin.\*

The most important of the Belgian plutonic rocks is the quartziferous diorite, found at Lessines and Quenast in the Silurian layers of Brabant. Delesse, who has made a chemical study of it, considered the base of that rock as a *residue* from crystallization, i. e. as a silicate whose variable elements are silicic acid, and all the bases which are found in the various minerals porphyrically developed in this rock. This eminent lithologist extended therefore to the rock in question his opinion concerning the constitution of the base of porphyries in general. But the microscope enables us to see that in the rock of Lessines and Quenast the base is composed of grains of quartz and feldspar forming a micro-granitoid agglomeration. As for the oligoclase which, together with quartz and more or less altered hornblende, makes up the essential elements of this rock, it presents a structure already observed in the plagioclases of trachytes and andesites. This structure is remarked in lines which are parallel to the outlines of the crystals. With ordinary light, these lines are of a feeble brownish colour; their

EXPLANATION OF PLATE CXXXVII.

- FIG. 1.—Oligoclase in the diorite of Quenast, showing a concentric structure. Polarized light.  $\times 40$ .
- " 2.—Epidote and calcspar, Quenast,  $\times 40$ .
- " 3.—Liquid cavities containing crystals of Na Cl enclosed in quartz, Quenast. The prismatic crystals are tourmaline.  $\times 450$ .
- " 4.—Crystal of labrador fractured and bent by *fluidal structure* in gabbro, Hozémont,  $\times 40$ .
- " 5.—Diallage in gabbro, Hozémont, showing the cleavages of that mineral,  $\times 25$ .
- " 6.—Diallage surrounded by fibrous hornblende,  $\times 40$ .
- " 7 and 8.—Ilmenite, covered in some parts by its characteristic white coating, in gabbro of Hozémont,  $\times 25$ .
- " 9.—Fragments of crystals of plagioclase and quartz, surrounded by Sericite in the elastic Porphyroid of Pitet. Polarized light.  $\times 120$ .

\* "Mém. sur les Caractères Minéralogiques et Stratigraphiques des Roches dites Plutoniques de la Belgique et de l'Ardenne Française," par Ch. de la Vallée Poussin et A. Rénard, S.J., t. xi. des "Mém. Couronnés de l'Académie de Belgique." This work, which is now in the Press, will soon appear.



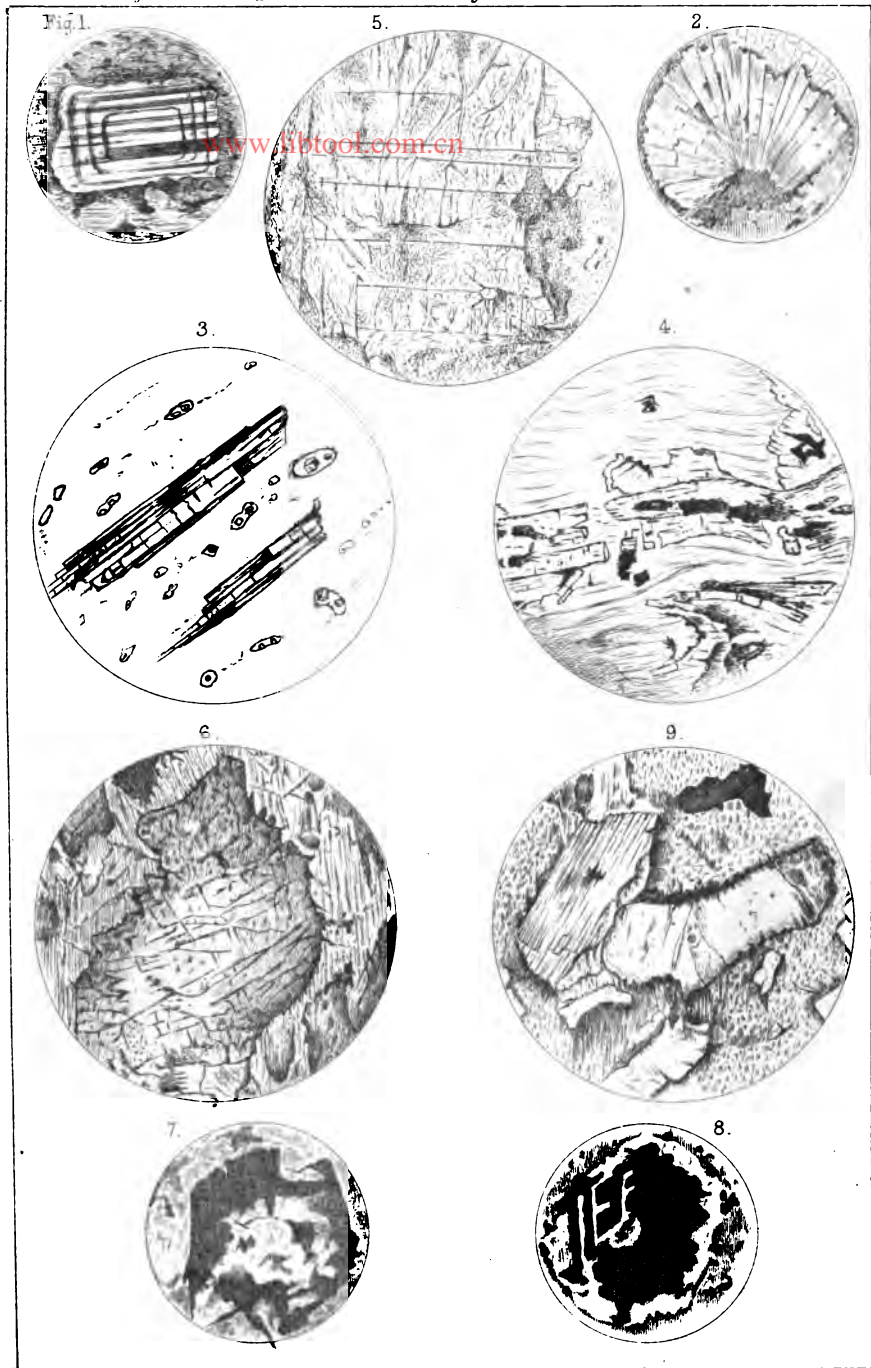



[www.libtool.com.cn](http://www.libtool.com.cn)

angles are not perfectly sharp; and, what is very remarkable, the lines which lie perpendicular to the polysynthetic lamellæ run clear through, without any break at the point where they intersect the striæ (Fig. 1).

In this diorit the microscope has enabled us to prove the presence of orthoklas, a result to which we have been led by the phenomena of polarized light, just as is observed in the twin crystals of Carlsbad. We need not stop to describe the microscopic details of the hornblende, which is generally much altered and often surrounded by an opaque zone in a state of decomposition, which has also obliterated the cleavages. This mineral often contains apatite, and this we consider to have been formed simultaneously with the hornblende; it is also intimately associated with chlorite, ilmenite, magnetic iron, biotite, epidote (Fig. 2), calcspar, and quartz; minerals which we believe to have been formed for the most part by the decomposition of the hornblende. Notwithstanding its state of decomposition, the sections of this mineral are still dichroic. We have also found in this rock uralite, augite, and diallage; and by means of the microscope we have proved the presence of crystals of apatite and ilmenite. These two minerals, which play an important part in the Belgian plutonic rocks, are always of microscopical dimensions, and had not been remarked in that country before we examined them under the microscope.

The microscopic study of the quartz of this rock is of the greatest interest, since it allows us to determine to a certain point the conditions in which this diorit was formed. Mineralogists have long been engaged in the study of the numerous minerals contained in quartz, and of the liquids enclosed in the cavities of this mineral; but it is especially Sorby, who by opening the way to a new method in petrography, has shown the geological importance of these phenomena. Following his example, and relying on the facts revealed by the microscope in the cavities of the quartz of this rock, we will endeavour to determine the temperature and the pressure at the moment of the crystallization of this rock.

The sections of the quartz of Quenast are rich in liquid cavities, but many of them, besides the bubble and the liquid, contain little cubic crystals (Fig. 3). An ellipsoidal cavity has enabled us to measure with great precision by means of the micrometer the dimensions of the cavity, those of the bubble and of the cubic crystal.

Major axis of the cavity .. .. .	0,mm00964
Minor axis of the cavity .. .. .	0,00660
Side of the cube .. .. .	0,00214
Diameter of the bubble .. .. .	0,00187

Of all the rocks subjected to microscopic examination, that of Quenast is perhaps, after the syenite of Laurvig, the one which

presents the greatest number of cavities with these little cubic crystals, whose faces are sometimes covered with parallel striations answering to the cleavage  $p (\infty 0 \infty)$ : It would be easy to prove that these cavities were formed and filled with the substances now found in them at the very moment of the crystallization of the quartz. By raising the temperature to about  $100^{\circ}$  C. we did not succeed in expanding the liquid; so that it is not liquid carbonic acid, but rather a saturated aqueous solution, as Sorby showed. The little cubic crystals gave rise naturally to the idea that the cavities are filled with a supersaturated solution of sodium chloride; their form and the parallel striæ which cover their faces call at once to mind the crystals of this same salt.

Following the example of Zirkel, Vogelsang, and Behrens, we investigated the nature of these microscopic crystals by spectral analysis. We carefully removed from the grains of quartz extracted from the diorite all the feldspar which could possibly remain attached to them. They were hardly put in the Bunsen flame when they slightly decrepitated, the cavities broke open, and the ray D appeared; this experiment repeated several times always gave us the same result. However, in order to be more assured of the exactness of our research, we wished to confirm it by an entirely different method. Some fragments of quartz reduced to a fine powder were put in a test tube of distilled water; when the grains of quartz had subsided we poured in a few drops of silver nitrate, the water became slightly milky, and presented the opalescent tint which characterizes the silver chloride.

Thus we think we can affirm that our experiments demonstrate that these cubes are crystals of sodium chloride, and the liquid in the cavities is a saturated aqueous solution of this salt. This result is not astonishing, if we reflect upon the analogy existing between the plutonic and volcanic rocks. The latter almost always, as is well known, show traces of this salt, and often are impregnated with it. We will now endeavour to find the temperature at which this water was enclosed, and therefore that of the rock at the very moment of its crystallization. We take as the ground of our calculation the experiments made on the solubility of sodium chloride in water. It has been observed that the solubility of this salt increases directly as the temperature. The cubic crystals contained in the cavity having been deposited by the liquid while it was cooling.

The micrometric measurements of the cavity, of which we have just spoken, furnished the elements for our calculation. The volume of the water was found 0,0000002198687 mm., that of the salt 0,00000098003. We had then only to ascertain to what temperature we should raise the volume of water to make it dissolve this volume of salt. On calculation we obtained for our

result a temperature of 307° C.\* By studying the rate of expansion of the liquid, Sorby concluded that the quartz in the trachyte of Ponza must have been formed at about 356° C., which may be looked upon as a very similar temperature. The number

\* The volume of the liquid cavity (an ellipsoid of revolution) is  $\frac{4}{3} \pi a b^2$ .

$$a = 0,mm,00482$$

$$b = 0,mm,00330$$

$$b^2 = 0,00001089$$

$$a b^2 = 0,0000000524898$$

$$\frac{4}{3} \pi = 4,1887901$$

$$E = \frac{4}{3} \pi a b^2 = 0mmc,0000002198687$$

$$\text{Bubble formula, } \frac{4}{3} \pi r^3$$

$$r = 0,00093$$

$$L = \frac{4}{3} \pi r^3 = 0mmc,000000003429$$

$$\text{Volume of the cube, } c = 0mmc,0000000098003$$

For the relation of the weight to the volume, we have the following formula: Water,  $P = V \times 1000$ ; for any given body,  $P = V \times 1000 \times \text{specific gravity}$ . In these formulæ, when V represents cubic mètres, P denotes kilogrammes. Consequently if V denotes cubic millimètres, P represents thousandths of milligrammes. Hence

$$V = \frac{P}{1000 \times \text{specific weight}}$$

$p$  denoting the weight of water contained in the cavity,  $\omega$  the weight of the salt (without the cube), we have at the temperature of these micrometric determinations, and admitting that in the solution of salt there is neither augmentation nor diminution of the total volume,

$$\frac{p}{1000} + \frac{\omega}{1000 + 2,26} = E - (L + C) = 0,000000206644 \quad [a]$$

2,26 is the density of salt at 0°; at 20°, the temperature at which the micrometric measurements were made, this density is less than the zero-value by some thousandths. We have neglected this slight variation. A similar allowance must also be made for the water. According to Regnault ('Chimie,' t. i. p. 456, table), at 0°, 100 grammes of water contain, when saturated, 35,5 grammes of salt; at 120°, 100 grammes of water, when saturated, 40,5 grammes of salt.

Moreover, the solubility increases in proportion to the variation of temperature; this gives an increase of  $\frac{1}{10}$  grammes of salt for a variation of 1°. Consequently, at 20°, 100 grammes of water contain 35,5 grammes of salt +  $\frac{1}{10}$ ; that is, 36,35 grammes.

We have then the equation,

$$\frac{\omega}{p} = \frac{36,35}{100} \quad [b]$$

By representing the weight of the cube by  $q$ , and the temperature at which the cavity was formed by  $t$ ,

$$\frac{\omega + q}{p} = \frac{35,5 + \frac{t}{24}}{100} \quad [c]$$

The

307° C. would be exact if the law of solubility of salt in water already referred to, was well established for high temperatures. Unfortunately experiments are wanted here. The law of solubility of sodic chloride remains constant to 120° C.; above this we are ignorant of its behaviour. Considering that superheated water becomes a powerful dissolvent of artificial glass in the experiments of M.M. Daubrée and Sorby, we are led to believe that its action upon sodic chloride is greatly augmented at 200° or 300°. The doubt upon this fundamental point permits us to assign to our number 307° only an approximative value. Accepting this as such, we will continue our examination of the physical conditions under which the crystallization of this rock has taken place. This is an example of calculation which will hereafter doubtless give results on which we can confidently rely. Knowing the temperature at which the cavity was formed, we can determine the pressure necessary to prevent, at this temperature, the complete evaporation of the water. It suffices to apply the formula of M. Roche.\*

---

The equation [a] gives  $p + \frac{\omega}{2,26} = 0,000206644$   
 " [b] "  $\omega = 0,3633 p$   
 " [c] "  $t = 24 \left\{ \frac{100(\omega + q)}{p} - 35,5 \right\}$   
 $p = 0,000178$   
 $\omega = 0,000064$   
 $q = 0,000022$   
 $\frac{\omega + q}{d} = 0,483.$

Hence  $t = 24(48,3 - 35,5) = 24 \times 12,8$   
 $t = 307°.$

\* The theoretical formula of M. Roche is the same as that found by Clapeyron, August, De Vrede, Holtzmann. "This formula," says M. Regnault, "represents the elastic force of aqueous vapour for a great extent of temperature with remarkable accuracy; it, indeed, between 100° and 220°, gives a result for the elastic force too great, but the greatest error only amounts to 35 millimètres. It is applicable perfectly to the vapour of water, and also to the vapours of alcohol and ether." M. Roche's formula is as follows:

$$F = a a^{\frac{x}{1+m x}}$$

In this formula  $x$  represents  $t + 20°$ ,  $t$  being the Centigrade temperature counted from the melting point of ice as zero, and according to Regnault's calculations:

$$m = 0,004884085$$

$$\log. a = 0,0386182275$$

$$\log. a = \bar{1},9590414$$

We obtain for our result a pressure of 66291 mm., or 87 atmospheres.

Another very interesting rock on account of its microscopical constitution is that which was designated by Dumont as hypersthénite of **Hozémont**; having found that it contains diallage instead of hypersthène, this rock should be called Gabbro. Chemical analysis has demonstrated that here the feldspar is labrador feldspar. In certain cases the thin sections of this gabbro show us the crystals of labrador broken; the broken parts are slightly separated from one another; and, what is important for our interpretation, the surrounding minerals and the base present the aspect of a mass bent, as is seen in the rocks of true volcanic character which have a fluidal structure (Fig. 4). The diallage such as we have found here should not be confounded with hypersthène, on account of its want of dichroism and because we find frequently the cleavage corresponding to  $h^1$  ( $\infty P \infty$ ) associated with another cleavage perpendicular to the former. This second cleavage is indicated merely by irregular and interrupted striae which correspond to the plan  $g^1$  ( $\infty P \infty$ ) (Fig. 5). This second cleavage, as is well known, is less easy than the other. Hence we never have the regular reticulated structure which should be found in augite. This diallage is frequently surrounded by little fibres of hornblende 0,3 mm. in length (Fig. 6). This fibrous hornblende is colourless, perfectly transparent, and dichroic. The minerals which constitute this rock are imbedded in a greenish substance, which under the Nicol prisms appears in some places monorefringent, and in others presents a sky-blue colour. Upon close examination this substance is found to be of a fibrous structure and offers an irregular network similar to that which is well known in the case of serpentine; although we have not met with olivine whose decomposition would have given the explanation of the presence of serpentine. Besides apatite we have also detected ilmenite, remarkable on account of its decomposition products, and which we will now briefly describe.

The sections of this titanite are surrounded and covered in some cases with coatings of an opaline substance perfectly homo-

$$\text{for } t = 307 \quad 1 + m x = 2,597095795$$

$$\frac{m}{1 + m x} = 120,91$$

$$\log. F = \log. a + \frac{x}{1 + m x} \log. a$$

$$\begin{aligned} \log. F &= \bar{1},9590414 + 125,91 \times 0,38618275 \\ &= \bar{1},9590414 + 4,86241700 \\ &= 4,82145840 \end{aligned}$$

$$F = 66291m = 87 \text{ atmospheres.}$$

geneous, which seems a result of the decomposition of ilmenite. The first stage of this decomposition is represented by the appearance of whitish veins running through the mineral; a second stage exhibits it enclosed in the opaline substance; finally, the metamorphosis can be pushed so far that nothing more is visible except a few black specks (Figs. 7 and 8). Its chemical composition has not been determined, but we have ascertained that it is unalterable by the action of hydrochloric acid, and therefore it is not carbonate of iron, as has been taught by some. We are, however, persuaded that the opinion of Gumbel, who admits that it is not a decomposition product, cannot be sustained.

In the Cambrian and Silurian beds of Belgium and of the Ardennes we meet with feldspathic rocks having at the same time a schistoid and a porphyritic texture, and which appear to be regularly imbedded in quartzites, slates, and schists. Dumont interpreted this feldspathic rocks as so many dykes injected between the adjacent layers; other geologists have admitted that these schisto-porphyric rocks were the result of a metamorphic action exerted at certain points. The stratigraphic study of these rocks in the Silurian of Brabant and their examination both with the naked eye and under the microscope have led us to admit for them an elastic origin. The microscopic characters on which we rely to demonstrate this fact are that the numerous feldspars in the thin sections are all without distinction broken or their angles blunted, and present at both extremities the appearance of fracture. In the same way the grains of quartz are not terminated by crystalline lines which have their regular form (Fig. 9). However, in other places in the same schisto-porphyric rocks we found indications that a part of the quartz has crystallized *in situ*. This latter mineral with sericite and triclinic feldspar constitute the essential elements of this rock. Hence we arrive at the same conclusion as Sorby, who considers some sericitschiefer of the neighbourhood of Wiesbaden as elastic, and we know besides that the rocks of which we are now speaking have the same identical schisto-porphyric structure and the same composition as those described by Sorby.

---



[www.libtool.com.cn](http://www.libtool.com.cn)

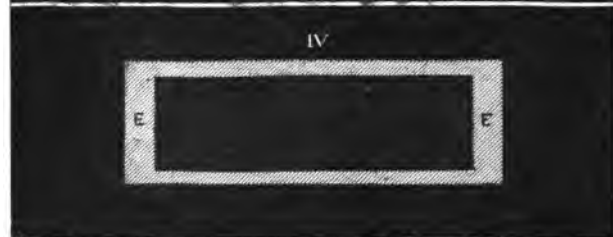
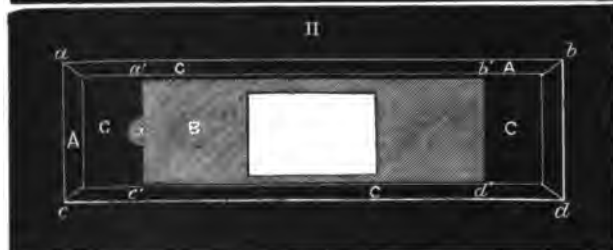
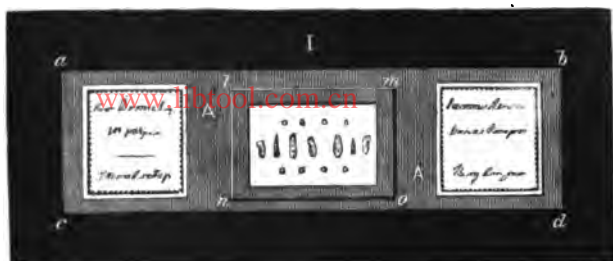

III.—*A New Microscopic Slide.* By M. ERNEST VANDEN BROECK.

Communicated by Professor RUPERT JONES, F.R.S.

(Read before the ROYAL MICROSCOPICAL SOCIETY, April 5, 1876.)

PLATE CXXXVIII.

THE great inconvenience with the ordinary slides is that in general there is no possibility, without breaking or squeezing the preparations, or at least damaging the label and glass cover, of adding to the mounted specimens or altering the preparation at all.

With the slides uncovered with glass there are the inconveniences of dust and damage to the specimens.

For good results the observer ought to be able to study the preparation by both transmitted and reflected light, and to be able to apply the object-glass at very short distances.

The following plan of preparing slides meets these difficulties.

Seen from above (Fig. I.), the new slide does not differ from ordinary slides; but turned over (Fig. V.) it shows a different principle of construction altogether.

Figure II. represents a piece of cardboard, or thin wood, B, of the size *a, b, c, d*, perforated in the middle. On the edges of this opening (which may be either round or square) is gummed a glass cover (Fig. I., *l, m, n, o*), and over its edge is gummed a strip of paper (red or blue), A, which is folded over below, Fig. II. Underneath the card B is gummed the card C, with its opening *a', b', c', d'*, Fig. II. Slips of ordinary microscopic glass are cut a little smaller than the opening *a', b', c', d'*; see Fig. III., D. With a little brush I then coat the glass slips with a thin layer of gum-arabic mucilage mixed with a little glycerine. Afterwards I cover the glass D with the paper D', which has an opening corresponding with that of the glass cover. (The frame of paper D' is to prevent the glass D sticking to the surface B when the glass slide is placed, with its Foraminifera, or other objects fixed on D, in the cavity *a', b', c', d'*, of Fig. II.) Then I have little oblong frames of very thin paper, gummed, Fig. IV., E, which are to fasten down the glass D, and keep it in the cavity *a', b', c', d'*, and exclude dust. When finished, the slide has the appearance of Fig. I. above, and Fig. V. on its under side; and it can be used with either transmitted or reflected light under different circumstances. For extra-large specimens, the perforated cardboard or wooden slips B may be doubled. To rearrange or add to the specimens, wet with a small brush the thin silver or tissue paper E, which is then readily detached. With the nail, for which a notch is left at *x* in Fig. II., the glass can then be lifted, and changes made in the preparation;

after which, by replacing the glass D in its cavity  $a'$ ,  $b'$ ,  $c'$ ,  $d'$ , and gumming on a new frame of thin paper, the slide is renewed, by this really simple, though apparently complex method.

The pieces of cardboard and wood, as well as the little frames of thin paper, can be obtained ready made, and already gummed as far as necessary, so that numbers may be put together in a little time.

---

IV.—*Measurements of Möller's Diatomaceen-Probe-Platten.*

By EDWARD W. MORLEY, Hudson, Ohio, U.S.A.

(Read before the ROYAL MICROSCOPICAL SOCIETY, March 1, 1876.)

SINCE Möller's Diatomaceen-Probe-Platte has to some extent become a standard of reference among microscopists, an estimate of the variability of the fineness of striation on its series of diatoms may have a certain interest for those who own or who have occasion to use the Probe-Platte.

It is obvious that the fineness of striation on an individual frustule of a given species of diatom mounted in balsam is by no means the only circumstance which influences the ease of its resolution with a given optical power and a given manipulative skill. Even if the same frustule be supposed to be remounted under different circumstances, differences in the refractive power of the balsam used may occasion slight differences in what may be called *absolute* resolvability; and different thicknesses of covering glass and of overlying balsam, by permitting a given objective to work under circumstances more or less favourable to its best performance, may occasion slight differences in *relative* resolvability. Further, if two frustules of the same species and of the same fineness of striation are compared under the same circumstances, their resolvability may be greatly affected by differences in the abruptness of the elevations and depressions which appear as striæ. The effect of causes like those now mentioned is obviously little capable of numerical statement.

Another cause which affects the resolvability of a given diatom by a given optical power, is the variation in the fineness of striation of different frustules of the same species. In the case of preparations like the one under consideration, where the refracting power of the balsam used may be assumed to be the same, where the thickness of the covering glass and overlying balsam is found to vary but slightly, and where it may be fairly assumed that the frustules of the same species on different Platten are selected from a somewhat homogeneous stock possessed of common characteristics and differing chiefly in the size obtained before growth was stopped, the difference in the fineness of striation will correspond tolerably with differences in the distinctness of individual striæ, and will be a better index of relative resolvability than if diatoms from widely different sources were compared.

For these reasons, as well as for the reason that the fineness of striation of the diatoms under consideration has a certain intrinsic interest, the writer has measured the striæ on the diatoms of ten of Möller's Probe-Platten. The measurements were all made with

the same objective; they were made as nearly as was convenient under the same circumstances; corresponding parts of the different frustules of the same species were selected for measurement; and the part selected was noted, so that, if the matter were worth the trouble, reference could be again made to the identical frustule and the identical part of it which was the subject of the present measurement. The objective used was an immersion  $\frac{1}{8}$ th made by Tolles; when used under the conditions of these measurements, its focal length was found to be sixty-two thousandths of an inch. The micrometer used was a cobweb micrometer by Troughton and Sims, of London; the value of a revolution under the conditions obtaining during these measurements was determined by the mean of twenty-seven comparisons with a millimeter divided into a hundred parts by Hartnack, and by a larger number of comparisons with a Paris line divided into a hundred parts whose author is not known. Care was taken to make the comparisons include the whole line and the whole millimeter in such a way as to eliminate the effect of inequalities in division.

For the first thirteen diatoms of the Probe-Platte, lamplight was employed except for Platte No. 258; for Platten Nos. 481, 535, 572, 586, and for the unnumbered Platte marked A, lamplight was also employed for diatom No. 14; for all others, sunlight was reflected by a heliostat through cobalt glass upon the concave mirror of the microscope. In measuring Platte No. 258, the micrometer was almost always in the tube of the microscope; with Platten A and 572, it was always mounted in a separate holder so that the micrometer could be manipulated without communicating tremors to the image of the object measured; in the case of the rest, the micrometer was mounted separately whenever sunlight was used for the illumination. When the micrometer was in the tube of the microscope, its wires were made to coincide with two striæ and the number intervening was counted two or three times; when it was in a separate holder, the wires were commonly made to coincide with the same stria, and one of them was then moved over a certain number of striæ which were thus counted.

Of the somewhat more than five hundred measurements thus made, three have been suppressed because they did not agree with other concordant results; some measurements it seemed superfluous to communicate, in which case the extremes have been given.

In the case of the diatoms from No. 2 to No. 10 inclusive, measurements were made on two specified parts of each frustule. It is thought that these measurements are mostly correct to within one or two units in the first decimal place. In the case of the remaining diatoms, two or more measurements were made as nearly

in the same place as was permitted by the fact that the number of striæ counted was usually varied. Here the variations in the numbers given for the same diatom frustule are mostly due to errors of observation. These errors were kept as small as seemed necessary for the purpose; that they could be made much smaller if required was proved by the result of extra care taken with diatoms Nos. 19 and 20 on Platte No. 258, where the variations from the mean were all very small. More time was taken for these two than for any others of the whole two hundred; an hour and a half of lamplight and an hour of sunlight were commonly sufficient for measuring the diatoms of one Platte.

In the table following, the first column gives the name of the diatom with its number; the second describes briefly the part of the diatom where the measurement was made; at the end of the table certain notes specify this part more accurately in certain cases. The other columns give the measurements for the Platten named at the head of each column; the first number gives the number of striæ counted in that measurement, and the second gives the number of striæ in the thousandth of an English inch. Under the names of the diatoms in this table are given the extremes for each one of the twenty in the series. In this statement of the extremes, it is assumed that the measurements for Nos. 1 and 2 are trustworthy to a unit in the first decimal place, those for the diatoms from No. 3 to No. 9 inclusive are considered trustworthy to half a unit; for the remaining diatoms the whole numbers corresponding most nearly to the fractional results of measurement are given with no expression of opinion as to the limit within which they are trustworthy. It may be stated that the widely divergent result for *Cymatopleura elliptica* on Platte A is not due to error; the result was re-examined after it was noticed that it was thus divergent.

Of course the amount of variation shown by these measurements is no index of the extreme variation in diatoms of any one of these species from different sources. But the variations found may be fairly assumed to show the order of magnitude of the variation to be expected among diatoms selected with care from the same source. It may be expected, for example, that samples of *Amphipectura pellucida*, carefully selected from the same stock, may vary as the numbers 92 and 95; while it could not fairly be expected that under these conditions there should be any such variation as from 80 to 110 or 120. The results to be obtained by the use of those diatoms on the Platte which are shown by the table to vary least when selected as Möller selects them, may be compared with no very wide limits of error, as far as such results depend on the fineness of striation of the diatoms in question.



	258	266	321	481	£35	572	586	A	B	C
1. <i>Triceratium foveus</i> ..	4 3·06 4 3·08	4 3·70 5 3·70	4 3·72 5 3·75	4 3·24 5 3·26	4 3·53 5 3·50	3 3·52 4 3·51	6 3·63 5 3·76	3 3·20 4 3·22	4 3·32 5 3·34	4 3·97 5 3·97
2. <i>Pinnularia nobilis</i> ..	15 12·5 14 12·1	20 13·0 18 11·8	13 12·9 14 13·8	15 13·5 13 12·8	13 12·4 13 12·4	11 12·0 12 12·9	16 13·1 15 12·4	13 13·7 12 12·5	11 11·7 12 12·6	14 13·6 15 14·0
3. <i>Nanicula lyra</i> , var. 14½ to 18	.. 24 16·3 25 17·1 ..	12 14·7 13 16·5 15 17·9 14 17·3	18 14·4 21 16·2 21 16·7 19 14·8	17 17·9 19 19·3 18 18·4 17 17·1	15 15·3 16 16·0 18 16·9 16 16·3	14 16·6 16 17·7 15 16·8 14 15·9	20 15·2 23 17·1 21 16·6 ..	15 15·8 15 16·6 15 16·4 14 15·1	16 15·8 17 17·0 16 15·8 15 14·9	17 15·8 18 17·0 16 16·0 15 14·5
4. <i>Nanicula lyra</i> ..	..	19 27·9	40 30·5	22 23·2	22 23·0	26 29·9	26 23·9	26 30·1	28 27·5	24 23·6
23 to 30½	36 25·0	19 26·6	20 27·6	24 24·3	19 25·2	20 22·9	31 25·1	22 25·3	25 24·7	26 24·8
5. <i>Pinnularia interrupta</i> ..	20 26·8	17 26·0	19 26·7	27 27·2	15 28·7	12 27·5	18 26·7	13 28·4	20 26·4	20 26·5
25½ to 29½	19 25·5	18 27·1	16 27·8	25 29·3	15 27·9	11 26·5	17 25·1	12 26·1	20 27·5	20 25·7
6. <i>Stauroneis phaeocentron</i> 31 to 36½	41 31·1	21 35·0	26 32·9	26 33·9	36 36·4	20 34·4	32 34·6	17 36·5	27 35·5	28 36·1
7. <i>Grammatophora marina</i> 36 to 39	..	20 34·0	26 33·7	27 35·5	35 35·4	20 33·9	32 34·5	17 36·6	26 34·1	27 35·2
8. <i>Pleurosigma Balticum</i> ..	57 36·3	22 36·5	33 36·8	29 38·2	29 37·7	20 38·8	38 38·4	25 37·4	38 37·7	29 37·5
32½ to 37	..	24 36·6	26 36·1	38 38·0	37 37·8	30 37·9	27 38·4	30 37·8	33 37·8	36 36·7
9. <i>Pleurosigma acuminatum</i> 41½ to 46½	50 34·3	27 35·9	25 34·8	35 35·2	25 33·7	30 33·2	37 33·1	25 34·1	37 37·0	36 36·6
43 to 49	..	27 36·0	23 32·4	28 36·8	36 33·9	30 35·8	33 33·1	25 33·2	37 36·9	36 36·6
10. <i>Nitzschia amphioxys</i> ..	52 42·7	31 41·7	25 41·4	34 45·5	23 41·8	25 42·8	40 46·3	25 41·7	43 43·3	34 43·5
43 to 49	..	31 43·8	25 41·4	23 44·5	24 42·8	25 42·5	25 46·6	25 41·7	32 42·1	33 42·8
11. <i>Pleurosigma angulatum</i> 44 to 49	46 42·9	33 45·8	29 48·7	24 46·0	25 46·4	25 48·5	34 49·2	20 47·3	34 48·0	37 47·8
60 to 67	..	28 48·2	27 47·5	37 48·8	25 47·1	20 46·5	28 49·3	20 45·1	33 47·0	37 48·2
12. <i>Grammatophora oceanica</i> 43 to 54	47 43·8	26 45·8	25 46·1	26 46·9	30 44·0	20 45·1	28 46·8	20 46·7	36 48·4	36 46·6
43 to 49	..	31 45·1	27 45·1	35 46·6	23 44·9	20 45·2	24 47·1	30 46·6	31 48·5	31 46·7
13. <i>Surirella gemma</i> ..	58 61·7	37 62·5	36 61·4	32 62·6	36 62·1	20 62·6	39 61·5	20 59·8	50 67·3	46 61·4
43 to 54	80 61·2	32 62·0	42 61·1	37 62·5	43 62·4	30 60·0	27 61·9	30 60·7	39 66·8	43 61·8
Upper edge	48 51·4	38 51·9	48 52·8	39 53·5	31 50·6	20 51·4	34 53·0	20 43·5	38 51·6	39 53·3
..	..	33 50·9	53 53·1	36 53·8	29 50·7	30 50·0	21 53·8	30 44·1	33 51·2	40 53·1
..	..	42 52·3	..	..	..	..	21 53·8	..	..	..

14. <i>Nitzschia sigmoides</i> 61 to 64	Near centre	63 63.0	64 63.8	47 62.5	46 61.2	37 62.2	20 60.4	37 61.9	30 62.8	47 62.2	48 62.4
15. <i>Pleurosigma fasciola</i> 55 to 58	"	46 56.5	21 57.0	20 55.7	25 56.5	30 54.7	20 55.3	20 57.8	30 55.6	20 56.2	20 54.6
16. <i>Sarrillea gemma</i> 64 to 69	"	42 56.2	21 57.1	20 54.8	21 55.8	30 54.5	30 55.3	17 58.2	20 54.5	20 54.9	30 55.2
17. <i>Cynatopleura elliptica</i> 55 to 81	Upper edge	40 55.5	22 57.5	40 55.2	20 56.1	20 55.2	..	..	..	30 55.6	40 55.8
18. <i>Navicula crassinervis</i> 78 to 87	Near centre	16 64.2	20 64.5	20 68.1	20 65.0	20 69.0	20 66.6	22 66.9	20 67.9	20 65.0	20 67.4
19. <i>Nitzschia curvata</i> 88 to 90	"	20 63.0	30 66.9	20 67.4	20 65.0	20 69.0	25 66.6	13 67.3	30 67.9	20 65.8	30 67.7
20. <i>Amphipleura peitucida</i> 92 to 95	"	20 64.4	40 62.1	20 68.2	20 65.0	20 69.5	20 66.6	..	..	..	30 68.2
	Upper edge	35 63.3	20 63.0	20 64.2	20 64.7	30 63.3	20 65.3	34 63.0	20 82.7	20 55.1	20 61.4
	Near centre	31 65.1	30 62.8	20 63.7	20 64.3	20 63.3	30 64.5	38 63.1	20 80.2	25 56.7	20 62.8
	"	26 62.7	..	..	..	..	..	..	20 78.5	25 54.9	..
	"	47 80.4	20 79.5	20 82.2	20 88.5	20 80.2	20 80.5	31 86.2	20 77.9	20 85.2	20 82.7
	"	24 79.3	20 78.8	20 82.0	20 85.2	20 82.0	20 80.6	22 86.2	31 78.9	40 85.2	40 82.8
	"	37 77.6	20 78.6	20 81.9	20 86.4	30 83.4	25 79.7	..	..	60 85.1	20 82.5
	"	..	..	..	..	20 83.4	..	..	..	..	40 81.5
	"	50 84.7	20 88.0	20 92.7	20 84.8	20 85.4	20 86.9	29 90.1	20 81.4	20 89.7	20 86.7
	"	25 84.5	20 83.3	20 89.2	20 84.0	20 86.9	40 86.2	26 89.8	20 82.2	40 89.7	40 91.7
	"	..	20 88.5	20 88.7	30 85.4	20 86.0	..	..	30 82.2	..	..
	"	..	..	20 89.7	40 84.9	20 85.9	..	..	..	..	..
	"	42 92.9	20 92.6	25 93.5	20 92.7	20 93.3	20 92.2	30 93.4	20 92.6	20 95.9	20 92.9
	"	43 92.7	20 93.8	20 94.8	30 94.1	20 93.5	30 93.1	17 96.1	20 94.6	30 93.6	40 92.9
	"	..	30 92.9	..	40 95.3	..	..	23 96.0	20 94.6	40 93.5	60 91.7
	"	..	..	..	..	..	..	27 95.3	..	50 95.1	20 91.7

NOTES OF EXPLANATION.

The figures at the head of the columns are the numbers etched by Möller on the Platten. Of the latter Platten which bear no number, that marked A is one lent to me by the Hon. P. H. Watson of Ashabula, Ohio; that marked B was lent me by Mr. K. B. Tolles, of Boston, Massachusetts, and that had the letter B written on it with a diamond; that marked C bears a label with the name of S. Wells, and was furnished me by Mr. Tolles.

The first of each pair of columns gives the number of striae on which the measurement was made, the second gives the number of striae to the thousandth of an English inch. The following notes explain more specifically the part of each diatom at which the measurement was made. The Platten was so placed that *Tricocerosium favus* appeared at the left hand.

1. Second or third row from margin.

2 and 6. Where the striae are most nearly at right angles with the margin.

3. First and fourth measurements at outer ends of striae, the others at inner ends.

4. Upper and lower ends of striae on upper half of frustule.

6. Inner ends of striae, near centre of frustule.

8. Some were measured midway between ends of frustule, some a little to the left.

10. On No. 886 both measurements were made at the lower edge.

11 and 16. As near the centre as was convenient.—Except where otherwise specified, all measurements were made midway between the ends of the frustule.

## PROGRESS OF MICROSCOPICAL SCIENCE.

*A New Mode of Colouring Sections of the Nervous System.*—M. Mathias Duval describes the following method recently pursued by himself, detailed in M. Robin's 'Journal de l'Anatomie' (February 1876). He states that whilst it is generally applicable, it is especially so with sections of the cerebro-spinal axis. The process consists of two methods, one of which is very old. It is, in fact, the addition of the blue coloration of aniline to the red colour of carmine, from which there results a violet tint more or less intense, and according to the nature of the parts of very varying degrees of tinting. Sections thus prepared should be mounted in Canada balsam or dammar resin. This is how the author proceeds: The section is at first coloured with carmine, according to the ordinary process; it should then, to be dehydrated, be submitted to the successive action of alcohol of thirty-six degrees, and of absolute alcohol. After the action of the latter it is plunged for a few minutes (from five to twenty minutes) into an alcoholic solution of aniline blue (aniline blue soluble in alcohol). In taking it from this bath it is placed in turpentine to be mounted in the ordinary way. Thus obtained, the pieces present a fine violet colour, which one would think too deep, but which present an extreme transparency beneath the microscope. The nerve-cells and axis-cylinders are indicated with the most marvellous distinctness. In fact, the author characterizes this method as compared with the simple preparation with carmine, by stating that the new preparation is compared with the old as a neat water-colour painting is as contrasted with a badly worked lithograph. The principal advantages of this method may be judged by what the author says may be seen in the sections: (1) The nerve-cells and axis-cylinders are of a violet, bordering on red. (2) The vessels are of a violet, bordering on blue, and are very distinct. (3) The envelopes (pia mater) which proceed from the pia mater and penetrate into the nervous centres, are all coloured a pure blue, so that they are readily distinguished from the rest. The author promises, in a future number, to express more at length the great advantages of this method.

*Relations of Nerves to Ganglia.*—A note on this subject has been recently presented to the French Academy by M. Ranvier, who states that minute experiments made by the writer have demonstrated to him that almost all the nerve-tubes which set out from the ganglion-cells, instead of preserving their individuality in directing themselves towards the centre or towards the periphery, presented T-shaped anastomoses with the tubes coming from the posterior roots.

*Structure of the Pancreatic Cells, observed during Digestion.*—It is said in a paper by Herr A. Heidenhain, which appears in Pflüger's 'Archiv' (vol. x.), that the following appearances were successively presented by the cells of the pancreas at the different stages of digestion:—1. During hunger the granular inner zone occupies the larger, the homogeneous

outer zone the smaller part of the cells. 2. In the first period of digestion, during which a plentiful secretion occurs, there is diminution of the entire cells by using up of the granular inner zone, then addition of new materials to the outer zone, so that this becomes enlarged. 3. In the second period of digestion, during which the secretion diminishes and comes to a standstill, there is a new formation of the granular inner zone at the expense of the homogeneous outer zone, most pronounced diminution of the latter, increase of all the cells. 4. With long-continued hunger there is gradual increase of the latter to their original dimensions, and therewith slight diminution of the inner zone. During the state of physiological activity there is a continual change in the cells—metamorphosis internally, addition of matters externally. Internally there is conversion of the granules into secretory constituents, externally employment of the nutrient materials for the formation of the homogeneous substance, which again becomes converted into granular masses. The average appearance of the cells depends upon the relative rapidity with which this process occurs. In the first period of change there is a more rapid consumption internally and more rapid addition externally: in the second period, the most rapid changes occur at the limit between the outer and inner zones, in that the substance of the former becomes converted into that of the latter.

*The Development and Succession of the Poison-fangs of Snakes.*—A paper was read at a late meeting of the Royal Society which had been written by Mr. Charles S. Tomes, M.A., and which is published in the following abstract in the last number of 'Proceedings of the Royal Society.'

At the conclusion of a paper upon the development of the teeth of Ophidia, published in the first part of the 'Philosophical Transactions' for 1875, I noted that there were peculiarities, which I had not then been able to understand, in the succession and development of the poison-fangs. Having reviewed the literature of the subject in that and in a preceding paper on the development of Amphibian teeth, I will pass at once to the description of the special features which distinguish the development of poison-fangs. Poisonous snakes are divided into two groups—those which have a shortened movable maxillary bone, which carries the poison-fang and another tooth; and those which have the maxillary bone longer, immovable, and often carrying other teeth behind the poison-fang.

In the former, or viperine poisonous snakes, the poison-fang is very long, and, when out of use, lies recumbent; in the latter, or colubrine poisonous snakes, it is, from the maxillary bone being fixed, constantly erect.\*

As fresh specimens are indispensable for a complete investigation of developmental peculiarities, I have only been able to examine one of the colubrine group, viz. the Indian cobra.

Of it one may say, roughly speaking, that the poison-fangs are developed just like any other Ophidian teeth, for a description of which I must refer to my former paper, save only that the tooth-germs are necessarily individually modified so as to produce the characteristic canalculated poison-tooth.

\* Günther's 'Reptiles of British India,' p. 165.

But in all the viperine poisonous snakes which I have examined, a strikingly different arrangement is displayed. Upon the movable maxillary bone there is room for two poison-fangs, side by side; and in a macerated skull the tooth in use occupies an extreme position, sometimes on one side, sometimes on the other. In sections displaying all the soft part *in situ*, the remaining space is generally occupied by a tooth which is in process of becoming attached; and, in whatever part of the area of tooth-development the section be taken, the successional teeth are arranged in pairs, in two parallel series. Thus there will be a right-hand series, consisting of the tooth in place and of four successors, and a left-hand series, consisting of the tooth next about to be in place and four successors.

When a tooth of the right-hand series has finished its period of work and is about to be shed, it is succeeded by a tooth of the left-hand series, which comes up by its side, and *vice versa*. A septum of connective tissue separates the two parallel series, and is continued out into the pouch, which conceals the poison-fangs when at rest, as a free hanging fold: its use appears to be to keep the long axis of the tooth in the right direction prior to its becoming firmly attached, and to prevent a right-hand tooth from getting into the place of one of the left-hand series, and *vice versa*.

It is obvious that this manner of succession is well adapted to avoid loss of time in the changing of the poison-fangs, for much can be done towards the fixation of a new tooth before the old one is detached. That the succession is both rapid and regular would appear to be indicated by the fact that the successional tooth-sacs are very numerous (often as many as ten), and that they are arranged in pairs, the two being almost absolutely alike in size and stage of development. Now as any given tooth of the one series is succeeded or preceded by its fellow in the other series, one might expect, if any great interval of time were to elapse, that the one would be materially more advanced than the other. When such is not the case, one is led to the inference that the succession is rapid and also regular.

In the cobra, the new tooth has to come into place and become attached after the loss of the old one; and this, it may be inferred, would take much more time. May this not be the explanation of the feat performed by Indian jugglers with the cobra, and their selection of this snake for such purposes? A cobra disarmed would remain harmless for some considerable period; a rattlesnake similarly treated would be furnished with a new weapon very speedily.

I have examined specimens in spirit of a few other colubrine snakes; and although such examinations are less satisfactory than the methods which may be pursued with fresh specimens, I believe it will be found to hold good that in those snakes which have a movable maxilla carrying but one tooth, the successional teeth are developed in two parallel series, this being the highest specialization of the poison apparatus.

On the other hand, in the colubrine poisonous snakes, approximating more nearly to the harmless snakes in having a fixed maxilla, sometimes carrying other teeth in addition to the poison-fang, the



successional poison-fangs are developed in a single series, like any other Ophidian teeth.

The development of the individual tooth-germ presents one feature of very great interest. A poison-fang tooth-germ is first formed, like any other, of an extinguisher-shaped enamel-organ (derived from an ingrowth of epithelium, which winds in and out amongst the tooth-sacs) and of a simple conical dentine-pulp.

As it elongates, a groove appears on one side, which, by deepening and by the approximation of its lips, becomes ultimately converted into the poison-canal. The enamel-organ, with its characteristic enamel-cells, passes without break or alteration into this groove; but still lower down is the tooth-germ, where the groove has become very deep; instead of the prismatic enamel-cells constituting a regular pavement epithelium, we have a reticulum of stellate cells, just like that gelatinous stellate tissue which forms so large a part of a mammalian enamel-organ. That the stellate reticulum is a non-essential structure I have previously shown; but the occurrence of such a tissue within the poison-canal, which it wholly occupies, and in which it represents the prismatic enamel-cells found higher up, strongly suggests the idea that it is a sort of retrograde metamorphosis of an active enamel-forming tissue into one which simply fills up a void.

It need hardly be added that a thin layer of enamel is developed upon the outside of the poison-fang; but none is formed on the interior of the poison-canal.

The base of a poison-fang is fluted (this is not the case with other Ophidian teeth), the dentine being convoluted as it is in the base of the tooth of *Varanus*, or in a labyrinthodont tooth; and it is attached to the bone through the medium of an opaque, ill-defined, calcified material, beyond which again comes a coarse bone. The fixation of a tooth is effected (alike in cobra and in viperine snakes) by a sort of scaffolding of coarse-textured bone, which is very rapidly thrown out from the surface of its finer textural maxillary bone. This "bone of attachment," met with, as I have elsewhere pointed out, in greater or less quantity wherever teeth are attached by ankylosis, is entirely removed with the fall of a tooth, and is developed afresh for its successor.

*Nerve-supply to the Thyroid Gland.*—In the last published part of the volume for 1875, of Robin's 'Journal de l'Anatomie,' M. Poincaré states that he has been struck with the great richness of this gland in nervous filaments of all sizes. This is the more curious, since the gland presents no remarkable indications either of sensibility or motility. No doubt the gland contains a large number of vessels, which require, consequently, many vaso-motor fibres, but the nervous supply is out of proportion to what may be supposed requisite for this purpose, and M. Poincaré thinks this peculiarity accounts in some measure for the close relationship known to exist between the thyroid gland and the generative organs, and believes that many of them are of a sensory nature. The nerves form close plexuses surrounding small islets of the substance of the gland, and the branches passing to and from the gland stand (as he expresses it) in the relation of

telegraphic cables between the thyroidean colony and the metropolitan cerebro-spinal axis. To continue the simile, the colony has itself an autonomous system of telegraphy, the stations being represented by numerous microscopic ganglia, with connecting branches which do not pass outside the gland. The best means of examining the nerves of the gland he finds to be, not hardening agents such as osmic acid, but softening and disintegrating agents, and he has obtained good results from maceration in water acidulated with acetic acid, and slightly coloured with fuchsine.

*The Minute Anatomy of the Thyroid Gland* has been very carefully worked out by Dr. E. C. Baber, who has been carrying on investigations on this subject in Dr. Klein's laboratory. It seems from an abstract of his paper, published in the 'Proceedings of the Royal Society,' No. 166, that on injecting the lymphatics of this organ with Berlin blue, by the method of puncture, they present the following characters: Traversing the gland, chiefly in a longitudinal direction, are large *lymphatic vessels* provided with valves. In direct connection with these, and permeating the gland in all directions, is a dense meshwork of *lymphatic tubes* and *spaces*. The smaller lymphatic tubes run between individual gland-vesicles, the larger between groups of the same. They accommodate themselves accurately to the intervals left between the vesicles, and where the intervals are larger they expand into irregularly shaped lymphatic spaces. They present no appearance of terminating in blind extremities, as stated by some authors. Injections with nitrate of silver show the lymphatic vessels, tubes, and spaces to be all lined with a continuous layer of endothelial plates. During this investigation it became necessary to study more carefully the interalveolar tissues. This led to the discovery in them of a tissue which does not appear to have yet been described. This tissue, which is designated by the author by the name of "*parenchyma*," consists of large rounded cells, each provided with an oval nucleus, found either singly or in groups amongst the epithelial cells. From appearances presented by the parenchymatous cells, the author concludes that they originate external to the vesicles by exerting pressure on the epithelial wall of the vesicles; they then produce a flattening and absorption of the same, and finally make their way through it into the interior of the vesicle.

*The Structure and Development of Antedon rosaceus*.—A very splendid memoir on the anatomy and physiology of this Echinoderm has been contributed to the Royal Society by Dr. Carpenter, and must be referred to now by our readers, from the utter impossibility of abstracting it without the plates which accompany the paper.\* The paragraph on the mode in which its food is digested may, however, be given. Dr. Carpenter says that the food of *Antedon* consists, not of the large bodies grasped and swallowed by ordinary Starfish, but of minute and even microscopic organisms; and that the so-called "tentacles" are entirely destitute of prehensile power was long since affirmed by

\* 'Proceedings of the Royal Society,' Jan. 20.



Dujardin, on the basis of observation of the habits of the living animal and of microscopic examination of the matters ejected from the vent.

"These statements are entirely borne out by my own careful observation of the actions of the brachial and tentacular apparatus, alike in the Pentacrinoid and in the adult condition, and by the microscopic examination I have repeatedly made of the contents of the alimentary canal. These consist of minute Entomostraca, diatoms, spores of algæ, &c., but especially, in my Lamlash specimens, of *Peridinium tripos* (Ehr.), which was usually very abundant in that locality. A powerful indraught current towards the mouth is maintained by the action of the large cilia that fringe the villous folds of the alimentary canal; but this does not extend to any considerable distance; and it is clear that minute particles are transmitted from the peripheral extremities of the arms and pinnules, along the brachial furrows and the radial furrows of the disk, to the neighbourhood of the mouth, where they come within the reach of the oral indraught. This I have repeatedly seen when I have had young Pentacrinoids alive under the microscope; and although I have been prevented, by the peculiarity of their position, from detecting the cilia to which the transmission is attributable, I can scarcely doubt that they belong to the epithelial floor of the furrows. And when I have detached small pieces of the soft parts from the arms of the living adult, I have found currents to be produced in the water surrounding them, which could only be accounted for by ciliary action. Thus the brachial apparatus may be regarded, in the first place, as an extended food-trap."

*Blood-globules in Typhoid Fever.*—M. Cornil has found, in the blood of the spleen of patients who have died in the third week of typhoid fever, large numbers of white globules, enclosing red globules to the number of five, six, or even more in a single cell. Other cells enclosed granules of hæmotosine. Although the existence in the blood of these large cells containing red globules is nothing new, nevertheless Cornil is the first to insist upon their multiplication in typhoid fever. The mesenteric glands, according to Cornil, are always inflamed in typhoid fever, in a manner analogous to the acute or sub-acute inflammation due to suppurative lymphangitis.

*Course of the Fibres in the Spinal Chord.*—Dr. Schieffendecker gives the following summary in Schultze's 'Archiv,' Band x. Heft 4:

I. Fibres passing out in different directions from the white substance into the grey regions.

A. Fibres, which originate at the same point, and pass over into the grey substance at different heights.

B. Fibres, which originate at different points of the white substance, and pass over, at the same point, into the grey substance.

C. Fibres, which belong to the same vertically extending bundles, and which, at the same height, bend over to the grey substance, often divide during their horizontal course in the white substance, towards the right and left, terminating in the grey substance, as bundles of different character.

II. Fibres passing in different directions, through the grey substance, for the purpose of connecting fibres.

A. Simple networks, *ea sunt*: 1, primary networks at the border of the white substance, combining the single bundles which have passed out; or 2, secondary networks, which, situated more in the middle parts of the grey substance, combine those bundles of fibres which have formed networks once before.

B. Courses of fibres which combine different large parts of the chord; these are:

I. The fibres of the posterior and the anterior commissures which combine the two halves of the chord.

II. The vertically running fibres of the grey substance which combine parts of different heights in the course of the chord.

III. Peculiar formations, probably for the purpose of connecting fibres of different character: the ganglion-cells with the delicate network involving the same.

*The Structure of the Stomach.*—Mr. H. Watney gives the following summary of his researches, which will soon be published in the 'Philosophical Transactions.' It relates to the anatomy of the pyloric end.

1. The surface is seen to present somewhat parallel folds; the stomach-tubes opening on the summits of these folds are longer than those which open in the depressions between the folds.

2. The epithelium is described as being closed during inanition, but open at its free extremity during secretion.

3. The germination of the epithelium is next described. The conclusions arrived at are:—that the epithelial cells divide; that the small rounded cells (other than the lymph-corpuscles) are the products of their division; that these small cells, increasing in size, rise up among the older cells, push them to one side and become short broad cells; that the short broad cells divide longitudinally, and form groups of two or three, or even more cells, which the author calls "epithelial buds."

4. A reticulum among the epithelial cells is described; it is found to be very delicate, and does not extend to the surface.

5. The membrana propria is found to be composed of large cells.

6. The muscle-endings in the plicæ villosæ are similar to those in the colon of the rabbit, already described.

7. Perivascular spaces are found in the upper part of the plicæ villosæ; these spaces are bordered by endothelial cells: the membrana propria forms the upper wall of the space.

8. The proper gland-tubes. A fine reticulum is described as occurring among the epithelium of these glands. The nuclei are found usually as flattened disks lying at the base of the cells. The nuclei are, however, during digestion occasionally found to be spherical in form. A third kind of nucleus was also found, which was possibly intermediate between the two other forms.

*Lignin in Plants.*—Herr A. Burgenstein contributed a paper on this subject to the Academy of Vienna. He states that experiments

were made with aniline sulphate, by which he determined the absence of lignin in fungi and algæ. It is found in a very few plant-hairs, in all wood-cells, but never in cambium. Many bast-cells have considerable lignin, but the sieve-cells hardly any. The most curious observation was that the walls of pith-cells in many plants are lignified, and the medullary rays also.\*

*The Roots of the Spinal Nerves in Elasmobranch Fishes.*—This subject, which is one of great difficulty, has been lately worked out by Mr. F. M. Balfour, B.A. It seems that the posterior and anterior roots of the spinal nerves arise as independent outgrowths from the involuted epiblast of the neural canal. The outgrowths for the two roots are at first quite independent of each other, and only unite at a late period of development. The posterior roots are the first to develop. An outgrowth arises on each side from the dorsal summit of the neural canal, which the author believes to be unbroken throughout its whole length. The outgrowths on the two sides are at first in contact with each other; and from each there springs a series of processes equal in number to the muscle-plates.

These processes are the rudiments of the posterior nerve-roots. They grow ventralwards in contact with the side of the spinal chord.

After the formation of the posterior rudiments, the original outgrowths from the spinal chord cease to be attached to it along its whole length, and remain in connection with it at a series of points only, each of which corresponds to a posterior root.

The result of these changes is the formation of a series of nerve-roots, each attached to the dorsal summit of the neural canal, and all of them united together dorsally by a continuous commissure, which is the remnant of the primitive outgrowth from the summit of the neural canal.

Subsequently the points of attachment of the posterior roots travel down the sides of the spinal chord, and finally remain fixed at about one-third of the distance from its dorsal summit.†

*The Placentation of Hyrax.*—On account of the differences of opinion which have been expressed on this point, the subject has been minutely investigated by Professor W. Turner, who, in a paper presented to the Royal Society in December last, goes minutely into the anatomy of this organ. He concludes that as "the placenta of Hyrax, both in the form of its villi and in the mode in which they are interlocked between the intraplacental maternal laminae, so closely resembles that of the domestic cat, and as these laminae remain *in situ* after the membrane, which I have named the serotina, is peeled off the placenta, there can be no doubt that they are shed at the time of separation of the placenta. Hence Hyrax, in its placentation, is one of the Decidua. Whether the membrane just referred to is also shed during parturition is more difficult to say. The fact that it peels off the uterus along with the placenta, when they are artificially

\* Vide 'Sitzungsber. der kaiser. Akad. der Wissen.,' lxx. i.

† See 'Proceedings of the Royal Society,' No. 165.

separated, is not of itself sufficient evidence. In the cat the whole thickness of the mucosa in the placental zone peels off along with the placenta when that organ is artificially separated; whilst in normal parturition the deeper part of the connective tissue of the mucosa, with the remains of the blood-vessels and tubular glands, persists as a covering for the muscular coat, and forms a non-deciduous serotina. It may be that in Hyrax, as in the cat, only the superficial part of this membrane is shed with the placenta, whilst the rest remains on the zone of the uterus; but this can only be determined by the examination of a uterus immediately after parturition."

*The Rotifer within the Volvox.*—The following observations are taken from a new American periodical devoted to microscopical science. The writer says that having watched the above phenomenon on one or two occasions, "and being desirous of keeping a few volvoes for future examination, and having formerly had very poor luck with such attempts, I took especial pains this time. I scalded two bottles thoroughly, and partially filled them with boiled water. When quite cold I placed a dozen volvoes in one bottle, taking them up with as little of the original fluid as possible. After an hour or two I transferred them, one by one, from the first bottle to the second, where they are now probably alone, and are thus far doing well. I examined each one carefully when first caught, and what was my astonishment to find several with rotifers in their interior, the rotifers being apparently very busy making a meal. That the inhabitants of these volvoes were rotifers, there can be no doubt. Carpenter describes the presence of amœbæ in the volvox, and explains it by stating that the endochrome-mass of one of the ordinary cells has assumed this condition. The phenomena which I have just seen certainly cannot be thus explained, and I feel puzzled to know how the rotifer got inside the volvox, while the latter appears to be unbroken and continues to swim about in the usual manner, carrying the strange 'entozoon' with it. That the rotifer is inside is easily shown by focussing down through the volvox. First we see the upper surface of the volvox, then the rotifer, and lastly the under surface of the globe."

*How to Measure the Angular Aperture of Object-glasses.*—There are many who possess the microscope with most of its accessories to whom the above question would prove a very formidable one indeed. We think therefore that the following condensed account, which has been given by Mr. Ingpen in the 'Journal of the Quekett Club' (January), which very briefly and clearly defines the various methods employed will not be without interest:—Down to the year 1854 the method of measuring angular apertures devised by Mr. Lister seems to have been the only one employed. This is described in the 'Phil. Trans.,' vol. cxxi., p. 191, and will be found in 'Quekett on the Microscope,' ed. 1855, p. 497. The microscope, with its objective and eye-piece as in ordinary use, is placed horizontally, a candle is set on a level with it, a few yards distant; the microscope is then turned, till, on looking through the eye-piece, the field of view is bisected,

half being light and half dark. The microscope is then turned round, with the focus of the objective as a pivot, until the opposite half of the field is illuminated. The angle can be measured by lines drawn on a suitable part of the instrument, or, preferably, by a divided semicircle. This method answers very well up to  $90^\circ$  or  $100^\circ$ , but for larger angles is not nearly so accurate as that devised by Mr. Wenham, and described in the 'Quart. Journ. Mic. Sc.,' 1854, p. 134. A lens of about a  $\frac{1}{4}$  in. focus being placed centrally, in a sliding cap, above the eye-piece, the image of the flame can be observed, and the angle measured with great accuracy; also the condition of the definition at the margin of the field can be ascertained, sometimes suggesting the utility of reducing the angle of the objective. This plan appears to have been used some years earlier by Amici. In the 'Quart. Journ. Mic. Sc.,' 1854, p. 293, Mr. Gillett's method is described: this was communicated to the Royal Society on March 9, 1854. The eye-piece is replaced by a cone having a small aperture, through which light is sent. The objective is focussed on an object which forms the centre upon which a second, or examining microscope, attached to a divided arc, turns. This plan is described in Mr. Hogg's 'Treatise on the Microscope,' 1871, p. 45, as "a very perfect instrument," but there seems to be some source of error connected with the employment of a second microscope. Professor Robinson's method was first brought before the Royal Irish Academy in 1854, and is described in the 'Quart. Journ. Mic. Sc.,' 1854, p. 295. Rays nearly parallel are sent through the eye-piece and objective, and intercepted by a screen at a distance greater than the focus. This distance, and the diameter of the base of the cone of rays so formed being known, the angle is easily calculated. This is a very elegant method, and likely to be valuable in certain disputed cases as to the true angle of immersion lenses. Mr. Sollitt describes a method, in the third volume of the 'Quart. Journ. Mic. Sc.,' 1855, p. 85, which he considers simpler than Mr. Wenham's. He does not use the Huygenian eye-piece, but a lens of  $1\frac{1}{2}$  inch focus, "as the eye-piece of a diminishing telescope." Two candles are employed, and moved till their images are seen at the extreme-edges of the field. This is described in 'Carpenter on the Microscope,' 5th ed., 1875, p. 202. It is open to the objection that if the observing lens is held obliquely, a distorted image of the candle may be seen at a greater angle than that which is engaged in forming the image of the object, and probably the angle is overstated. Mr. Wenham's (or Amici's) method seems to have been again re-invented, as it is attributed by Mr. Brooke ('Quart. Journ. Mic. Sc.,' 1864, p. 84.) to Professor Govin, of Turin. It was used in the examination of objectives at the International Exhibition of 1862; the only differences were the employment of a combination of two lenses instead of a single lens, the instrument being placed in a vertical instead of a horizontal position, and strips of white paper on a dark cloth used instead of candles. In the 'Quart. Journ. Mic. Sc.,' vol. vii., p. 256, Mr. Peter Gray examines the images of two flames in the objective without an eye-piece, which amounts to a re-invention of Mr. Sollitt's method. Mr. Stephenson, adopting the same system,

places two flames, such as night-lights, at known distances apart, and using the objective alone without any tube, has a very convenient scale of tangents engraved upon paper, thus showing the angle by inspection. This is described in the 'Month. Mic. Journ.,' July, 1875, p. 3. In the 'Month. Mic. Journ.' for May, 1874, p. 178, Mr. Wenham describes an adjustable slit formed by two slips of very thin platina foil, which can be separated to the exact diameter of any field of view, thus excluding all but "image-forming rays." This is a very valuable adjunct, and greatly conduces to accuracy; and when used with a divided circle, with small flames at a suitable distance, or white crosses on a black ground, and with a lens or lenses centered and sliding above the eye-piece, it forms a very suitable and accurate combination.

*The Development of Gasteropod Mollusks.*—We learn from a note in the 'American Naturalist' for March, that at a meeting of the Boston Society of Natural History on February 2, Dr. W. K. Brooks read a paper on the development of *Astyris* (*Columbella*) *lunata*. This, that journal states, is the first siphonated gasteropod whose embryological history has been followed. Some general views on the molluscan pedigree were added.

*State of Chord in Death from Paresis.*—Dr. C. E. Mann says\* that in a recent case of death which occurred in a person who suffered from Paresis, upon hardening the spinal chord and making thin sections, and employing carmalum staining to demonstrate the structural relation more clearly, there were found to be, upon microscopical examination, atrophy and degeneration of the nerve elements of the posterior columns, with increase of connective tissue. Sections of hardened brain-tissue being made, there was observable, in the cerebral cells of the frontal convolutions, a diffused granular degeneration. No change could be detected in the cervical sympathetic, which was carefully examined.

*Difficulties of Classification of the Spongida.*—Mr. H. J. Carter, who has recently written upon this subject, says, in a report published in the 'Annals' of Nat. Hist., that in the general classification of the Spongida there is not much difficulty, as the skeleton (which too often is the only part that reaches us, from the inaccessible places in which many of them grow and the accidental circumstances under which they reach the shore) consists of durable material which, in structure and composition, admits of very easy arrangement; while where there is no skeleton at all, this alone for such sponges is sufficiently characteristic of the order. But in the more particular classification there are peculiar difficulties, inasmuch as there is no expression in sponges as in other animals and in plants; that is, there is nothing like a *calice*, as in the coral, and nothing like a *flower*, as in the plant, to guide us—what there is in this respect, viz. the *spongozoön*, being microscopic in size, undistinguishably alike and so protean in form as only in its active living state *in situ*, or just after it has been eliminated

\* 'New York Med. Journal,' February.



from the sponge, distinguishable from a common amebian animal. Again, as regards the general form of the sponge itself, there are many instances where the same form may be assumed by totally different species, and the same species assume different forms, so that a microscopical examination of the "proper spicule" can alone determine the species; thus a fan-shaped and a vase-like form respectively may have at one time the same, and at another a different form of spicule. And yet again the aid derived from the form of the "proper spicule" is confined to sponges so provided, while those which have nothing but foreign objects instead of the "proper spicule" are even without this aid. So that, after all, we may be thrown back upon structural peculiarities in combination with general form, and perhaps sometimes colour, for ultimate distinction. (This will be found to be particularly the case with the *Hircinida*.)

Still there are many instances where the same species may be hastily recognized by its outward features; but as this can only be done after much experience, it is of no use to a beginner. At the same time, from what has been above stated it would always remain uncertain, even to the experienced, without a microscopical examination.

A fresh sponge, too, described in its natural state (that is, with the sarcode on), differs greatly from that in which the sarcode is off, or where the skeleton only remains. As, however, by far the greater number of sponges come to us in the latter state, and, indeed, all must be divested of the sarcode before they can be usefully described for classification, seeing that, as before stated, there is no animal expression (so to term it) externally or internally that can be made use of for this purpose, it seems best to describe the skeleton naked, rather than under cover of the sarcode—that is, to describe the skeleton only, although, of course, where this can be done with the sarcode on as well as off it is best of all. But there is no doubt that a description of the sponge with the sarcode on will never serve to recognize its skeleton, which is at once its most characteristic and frequently the only part that we can or are most likely to obtain from the inaccessible localities in which many grow; so after all we are not so badly off with the skeleton only, provided it has not been worn away by much attrition. Hence the fundamental divisions of my arrangement will be based on the characteristic features presented by the elementary composition of the skeleton or organ of support. It should not be forgotten, however, that with the sarcode of course the flesh-spicules disappear, falling through the skeleton, as before stated, like small pebbles through the meshes of a fishing net, when the sarcode passes into dissolution. Nor should it be forgotten that there may be a great difference between a sponge in its "fresh" and in its dried state, in size, colour, and general appearance. As the sarcode in all assumes the character of glue when dry, those which, like the *Carnosa*, are without horny skeletons can only be described when fresh or preserved in some aqueous solution. Also sponges possessing a skeleton sink down in many instances to half their original size by the shrinking up of the sarcode, which, clinging



round the skeleton, destroys the original plumpness of the sponge, and thus alters considerably its general appearance externally as well as the structure internally. Lastly, the colour under drying, as before stated, may fade in part or altogether. Still there are some things in a sponge which are seen better when dry than when fresh. Such difficulties beset no other classification in natural history. But what is to be expected otherwise, when, in addition to this, the protean character of the sponge, whose transformations are endless in the soft parts, and only approached in number by being stereotyped in the harder ones, is considered?

---

## NOTES AND MEMORANDA.

---

**Soirée of the Royal Microscopical Society.**—On the 21st of April, through the courtesy of the President, H. C. Sorby, Esq., F.R.S., was held one of the most brilliant evenings that the Royal Microscopical Society has enjoyed for many years. Ladies as well as gentlemen were admitted, and it is but just to say that the microscopic specimens exhibited were both vast in number and exceedingly original in character. All the arrangements were of the most consummate excellence, and the whole affair will be fully reported in our next number.

**American Postal Micro-Cabinet Club.**—We learn that a year's experience in the working of this organization has already given it the position of a useful and well-sustained institution. The first announcement of the formation of the club was so favourably received, that an unexpectedly large number of members was enrolled, since which time its membership has steadily increased until it now numbers twelve circuits of members, distributed over the whole country east of the Rocky Mountains. With the exception of a remarkably small number of accidents to objects while in transit by the mails, which it is believed will be still fewer in the future, the club has met with no practical difficulties or disappointments. The general excellence as well as the variety of objects contributed has been conspicuous; and those members, if there are any, who can learn but little from the work of others in various departments of the science, must at least feel that they have contributed widely to the advantage of others at very little trouble to themselves. In addition to the circulation and study of mounted objects, critical notes upon the same, questions and answers, and announcement of duplicates for exchange, it is proposed to add during the present year the exchange of microscopic objects and material, whether mounted or unmounted, not necessarily connected with the slide contributed; any member adding at the bottom

of his note a statement of offers or wants, and other members addressing him directly by mail, in regard to the same.

**Instructions for Cleaning Foraminifera of the Chalk.**—Mr. C. J. Muller kindly sends us the following note:—Having obtained a quantity of the shells by the usual process of elutriation, mix it with four or five times its bulk of silver sand which has previously been well washed, and put the mixture in a long 2 or 3 ounce phial with a sufficiency of water. Shake up the whole (not violently) for ten or fifteen minutes. Let it rest for three or four minutes, and then pour off the turbid water. Renew this operation as many times as you like. The Foraminifera will always settle down last, and form a distinct stratum upon the surface of the deposited sand. The sand when shaken up with the shells will act as a gentle rasp, and remove from their surface most of the hard granular particles which injure their appearance. When the cleansing operation is completed, the water will rapidly clear upon the mixture being set aside for three or four minutes.

There is no difficulty in separating the shells from the sand. Let the whole quietly settle down; pour off the clear water, and allow the whole to rest for a few minutes. Now add a fresh supply of water rather forcibly, when the shells will immediately rise, leaving the sand below. The water with the shells must now be poured off, before they have time to settle down, into another vessel where they may subside. The deposit may then be dried and mounted in dammar or Canada balsam in the usual way.

## CORRESPONDENCE.

### PROFESSOR KEITH'S CRITICISM.

*To the Editor of the 'Monthly Microscopical Journal.'*

SIR,—I am quite willing to meet fair discussion relating to the principle on which I have asserted that the measured apertures of all object-glasses have hitherto been greatly in excess of the true angle.

Professor Keith's letter in your last issue appears somewhat superfluous, as it does not in any way help to elucidate the point. First, merely on his own judgment, he attributes "errors" to me—not considering that such have yet to be proved.

The remainder of the letter resolves itself into the assertion that it is "possible to compute the spherical aberration of any combination of lenses, and with any degree of accuracy." Very well; I shall be glad if this can be done, so that the tedious trial and error

method still carried on in the workshops for effecting new combinations may be dispensed with, by a previous computation "not difficult."

Of course there is but little use in such a calculation if *anticipated* by the practical result to which it is applied.

Yours very truly,

F. H. WENHAM.

### ZEISS' OBJECTIVES.

*To the Editor of the 'Monthly Microscopical Journal.'*

66, KINGSDOWN PARADE, BRISTOL, April 10, 1876.

SIR,—If in the note published in your February number (p. 96) I had invidiously pitted the Zeiss dry objectives against Powell and Lealand's new immersion, I must have acknowledged myself open to Mr. Hickie's courteously expressed strictures. As, however, my remarks can hardly be so interpreted, I demur to the indictment. I went, indeed, a little out of the way to do justice to the Zeiss lenses (as I considered they fully deserved), for my concern was to vindicate the new  $\frac{1}{4}$ th from an unmerited charge of want of penetration, which is practically tantamount to limited usefulness. Now penetrative power is usually considered to increase as the angular aperture is lessened; a belief which these Zeiss glasses of remarkably small angle seemed capable of putting to a severe test. It was in the one quality of penetration that I compared the  $\frac{1}{4}$ th with the Zeiss lenses, and these were bound to be dry ones, as no low-angled immersions are made either by him or others. That the Powell and Lealand glass should fully equal them in penetrative power was, I confess, an agreeable surprise, which I think few would have anticipated. I made no comparison between the relative resolving powers, as this would have been manifestly unfair towards glasses of little more than half the angular aperture of the new  $\frac{1}{4}$ th; but I may say that even in this the dry Zeiss lenses appear to be satisfactory. I have not tested them very critically myself, but while I was at Sidmouth last autumn, the Rev. Lord S. G. Osborne showed me fine "resolutions" with a dry Zeiss  $\frac{1}{4}$ th skilfully manipulated, and he writes me that he has since greatly surpassed them by the aid of some newly-devised arrangements.

I was led to mention the amplification of the Zeiss glasses, not only because, as Mr. Hickie indicates, the foreign numbers convey no information to us, being taken at a much shorter distance than our standard 10 inches and with lower eye-pieces, but also because my figures do not agree with those given by Zeiss. He states the diameters yielded by his  $\frac{1}{4}$ th and  $\frac{1}{8}$ th to be  $\times 330$  and  $\times 500$ , whereas I found them as  $\times 330 : \times 451$ , showing that one must have been considerably over- or the other as much under-estimated. Possibly different specimens of his lenses, nominally the same, may vary in

power between themselves, which is, I am sorry to say, not unknown amongst our own makers. This never tends to inspire confidence in the accuracy of the rest of the work, and that it is by no means unavoidable is proved by the closeness of Messrs. Powell and Lealand's working. These gentlemen made me a special 1 inch of  $20^\circ$  and  $\frac{1}{2}$  inch of  $40^\circ$ , and I found the power to be (with their No. 1 ocular)  $\times 52$  and  $\times 105$  respectively; their catalogue giving the round numbers  $\times 50$  and  $\times 100$ .

Undue discrepancies in amplifying power may cause confusion in purchasing lenses. I may name a case in point. Through the kindness of Mr. Wenham I became the fortunate possessor of the original  $\frac{1}{4}$ th which he had worked up to  $120^\circ$  on his new principle. The exquisite defining and resolving power of this particular glass rendered it a most valuable acquisition, but it fell short in one respect. I imagined that in it I was adding to my series a power a step higher than my Andrew Ross  $\frac{1}{4}$ th (1854), but I found it, in fact, very much lower. With Ross' B ocular at 10 inches, and with the screw-collars set half-way, the  $\frac{1}{4}$ th gave  $\times 406$ , and the  $\frac{1}{4}$ th  $\times 360$  only. This could not have been surmised from any published list, since A. Ross's catalogue of 1853 gives his  $\frac{1}{4}$ th with B =  $\times 350$ , while Ross and Co. in 1872 set down their  $\frac{1}{4}$ th as  $\times 425$  and in 1875 as  $\times 400$ .

While on the subject of amplification I may be excused for alluding to a point which I have reason to know is occasionally misapprehended, however trite it may appear to the bulk of your readers. The published lists of magnifying power in the opticians' catalogues must not be supposed to furnish even a rough approximation to the amplification with which an object will be seen in the microscope with those objectives. To admit of comparison, these lists are compiled on the conventional assumption that the distance from the eye-lens to the stage is always uniformly 10 inches; whereas with low powers and long bodies it may really reach 16 or 18 inches, with a proportionate increase in magnifying power. Hence every microscopist should work out for himself two tables of the power of each of his objectives with his various oculars; one at 10 inches to compare with published lists, and the other, and by far the more important one, at the *working distance* in each case. It is almost superfluous to hint how this is done. The microscope being set horizontally, the paper on which the images of the stage-micrometer lines are to be marked, is placed in the first case exactly 10 inches below the centre of the reflecting surface of the camera, and in the second, exactly as far from it as that is from the surface of the micrometer, when the images of the lines (or the outline of any object) will be traced of precisely the same size as they would appear to the eye on looking through the instrument in ordinary work. "Personal equation," however, comes into play here. The magnifying power as determined by a long-sighted and a short-sighted observer will vary by a very notable constant difference. In all such trials the screw-collars (if any) should be set to the same point in each case, or serious discrepancies may arise, perhaps not always unintentionally.

Such elaborate comparisons between different objectives as those

given by Mr. Hickie are very valuable to workers if thoroughly performed and conscientiously reported ; but I may be pardoned for suggesting that in future cases they would be still more useful if a typical glass of some English maker were included in the trial. Many who may be hesitating between investing in, say a Powell and Lealand and a cheaper Zeiss or Gundlach, would be glad to gain some notion as to how much they would lose in quality by choosing the latter, though they might be supremely indifferent as to the precise relative value of the work of Seibert or Schieck—names almost unknown here. Moreover, if Zeiss were paramount among his compatriot makers, we must not forget that the one-eyed would be king among the blind.

I presume Mr. Hickie\* means the ordinary silvered mirror, and not a silver speculum.

Mr. Dallinger doubtless (though he does not name it) has some arrangement for constantly placing his new lamp and the microscope in the same relative position, as by dropping them into sockets in a base-board, since that would greatly facilitate adjustment. The supplementary stage he speaks of is probably similar in principle to that which I described in 'M. M. J.' six or seven years ago in connection with Reade's diatom-prism, and which I find eminently serviceable.

I am, Sir, yours obediently,

FREDERICK W. GRIFFIN.

## PROCEEDINGS OF SOCIETIES.

### ROYAL MICROSCOPICAL SOCIETY.

KING'S COLLEGE, April 5, 1876.

H. C. Sorby, Esq., F.R.S., President, in the chair.

The minutes of the preceding meeting were read and confirmed.

A list of donations to the Society since the last meeting was read by the Secretary, and the thanks of the meeting were voted to the donors.

The President said they were favoured that evening by the presence of M. Rénard, of Louvain, who was the author of the paper to be read on that occasion ; he had, however, preferred rather to have his paper read than to read it himself, therefore Mr. Charles Stewart would kindly undertake to do this.

Mr. Charles Stewart then read the paper by M. Rénard, "On Some Results from a Microscopical Study of the Plutonic and Stratified Rocks of Belgium." The paper was illustrated by an explanatory drawing made on the black-board by the President, and by a series of

\* Foot of p. 193.

beautifully executed chromo-lithographs, which were handed round for the inspection of the Fellows. (The paper is printed at p. 212.)

The President felt quite sure that it would be the pleasure of all who were present to return their thanks to M. Rénard for his admirable paper; and they would do so with the greater satisfaction, seeing that it was not often they had the advantage of a paper from a distinguished foreign gentleman. The subject was one of much importance in geology; indeed, there were few considerations of more importance than the temperature at which these rocks were formed; and he thought they might well congratulate themselves upon having brought before them the first paper which had been written upon the subject of a new method of obtaining this temperature. He felt personally much gratified to find that the results arrived at by M. Rénard agreed so nearly with those which he had himself obtained some time ago by a totally different process, his calculations being based entirely upon the ratio of expansion of liquids, making the cavities, in fact, act as self-registering thermometers. (Diagram drawn on board.) When now examined, the cavities were found to be only partially filled with fluid, and he had proceeded to find the temperature necessary to expand the fluid sufficiently to make it fill the cavity entirely. He thought it worth noting that M. Rénard's temperatures may not be the actual temperatures at which the rocks were formed, because he assumed that the liquid was in a state of saturation; but if this were not actually the case, then M. Rénard's calculation may be really less than the true temperature, though it was clear that whatever that might be, it could not be less than that assigned by M. Rénard. Considering the nature of the two methods employed, that they were conducted upon entirely different bases, and were independently arrived at, he thought the results were very remarkable, M. Rénard having found the temperature to be  $307^{\circ}$  C., whilst he had himself placed it at  $356^{\circ}$  C., or a difference of only  $49^{\circ}$  C. These figures seemed to show that those rocks had not been formed at such a high temperature as some geologists had thought possible. It was, in fact, not more than a dull red heat—a heat so dull as to give out scarcely any light in the dark. He thought they must certainly congratulate themselves upon having such a paper, and upon having it brought before them for the first time.

The cordial thanks of the Society were unanimously voted to M. Rénard for his paper.

The Secretary called the attention of the Fellows to an improved form of microscope and mounting lamp, designed by Mr. Sear and manufactured by the Silber Light Company, which was placed on the table for exhibition. It gave a very powerful light from a silver burner; and in addition to this advantage it had a heating table placed over the lamp, on which slides might be warmed or dried as required.

The Secretary said they had received a short paper from Professor Rupert Jones—written by M. E. von Broeck—describing a new kind of slip for mounting opaque objects. It was a contrivance for fastening on the glass cover by means of tissue paper, in such a way that it might easily be removed if it became necessary to get at the specimen,

which could not be done if the cover were cemented down in the usual way. The paper would be taken as read, and of course it would appear in the Journal. (See p. 221.)

The thanks of the Society were voted to Professor Rupert Jones for his communication.

The Secretary then read a paper which had been received from Dr. J. J. Woodward, of the United States' Army Medical Department, "On the Markings of *Navicula Rhomboides*." The paper had special reference to the remarks made by Mr. Hickie at a former meeting of the Society, and some very beautifully executed photographs in illustration had been forwarded with the MS.

The President felt sure all would unite in voting their cordial thanks to Dr. Woodward for his paper. He was for his own part extremely glad to have an opportunity of seeing these very beautiful photographs; he only wished that in this country they could photograph these things as well.

The thanks of the meeting were unanimously voted to Dr. Woodward for his paper and the accompanying illustrations.

In answer to the President's request, Mr. John Mayall, jun., said:— I think it is perfectly evident from the reasoning in Dr. Woodward's paper, that the diatom which Mr. Hickie calls *Frustulia Saxonica* is identical with the *Rhomboides* which Dr. Woodward has photographed from Möller's Typen-Platte, copies of which are before us. The photographic evidence here adduced is of a novel character, so far as I know, in deciding a question of identity of form and definition in a microscopic object. Mr. Hickie exhibits photographs of a diatom which he calls *Frustulia Saxonica*; Dr. Woodward examines copies of them, and finding the striæ—or rows of hemispherical beads—to be of just about the same degree of fineness with those on the *Rhomboides* when the whole diatom is magnified so as to be of the same length, he comes to the conclusion that the objects photographed must have been practically the same. So far as similarity of outline and definition can make out a clear case for the identity of two diatoms, I consider Dr. Woodward has succeeded in proving that Mr. Hickie's *Frustulia Saxonica* is simply a coarse form of *Rhomboides*. Everyone who is familiar with the *Frustulia Saxonica*—photographs of which Dr. Woodward sent in illustration of his paper in December—knows it to be one of the most difficult test-objects, a diatom that ranks next to *Amphipleura pellucida*. That particular form of *Frustulia* is one that I have rarely seen resolved except by lenses of the highest excellence. I considered Dr. Woodward's photographs of it as in every way most remarkable, evincing first-rate skill brought to bear on one of the finest known lenses. I am unable to comprehend the grounds on which Mr. Hickie seeks to depreciate those photographs. That he should for an instant appeal to Seibert's photographs of *Rhomboides*—or as he chooses to call the diatom, *Frustulia Saxonica*—as being finer examples of manipulative skill, proves to my mind that he knows little or nothing of the difference between obtaining clear images of an easily resolved diatom, and similar images of a really difficult object—one that taxes the lens to



very nearly the limit of its power. In Seibert's photographs of Rhomboides, the diatom was of quite easy resolution, and yet by mismanagement of the illumination an imperfect definition was obtained. This is clearly seen by comparison with Dr. Woodward's photographs. Here Dr. Woodward has taken in hand a Rhomboides in every respect corresponding to Mr. Hickie's diatom, but instead of mere transverse and longitudinal lines which are not the true resolution, he exhibits rows of hemispherical beads with a clearness and definition that unmistakably show that he stands unrivalled in the work he has made peculiarly his own. With these photographs before me, I can only conclude that Mr. Hickie has meddled with a problem for which he is incompetent, and his criticisms on Dr. Woodward appear to me utterly worthless.

The Council gave notice of their intention to propose the Count Castracane for election as an Honorary Fellow of the Society.

The meeting was then adjourned to May 3.

Donations to the Library and Cabinet since March 1, 1876:

Nature. Weekly .. .. .	From The Editor.
Athenæum. Weekly .. .. .	Ditto.
Society of Arts Journal .. .. .	Society.
Journal of the Linnean Society .. .. .	Ditto.
Transactions of the Watford Natural History Society .. .. .	Ditto.
An Account of certain Organisms occurring in the Liquor Sanguinis. By William Osler, M.D. .. .. .	Author.
On the Pathology of Miner's Lung. By William Osler, M.D. .. .. .	Ditto.
Le Diatomacée in Tunisia observate Dal Dot. Matteo Lanzi .. .. .	Ditto.
Structure and Development of Pareira Stem ( <i>Chondodendron tomentosum</i> ). By John Moss .. .. .	Ditto.
Popular Science Review. No. 59 .. .. .	Editor.
Smithsonian Report, 1874 .. .. .	Institution.
Istruzioni per chi Voglia Raccogliere Diatomee memoria ab Francesco Castracane, 1875 .. .. .	Author.
Contribuzione alla Florula delle Diatomee del Mediterraneo ab Francesco Castracane, 1875 .. .. .	Ditto.
Three Slides of Minerals .. .. .	F. Rutley, Esq.

C. S. Bentley, Esq., and Philip J. Butler, Esq., were elected Fellows of the Society.

WALTER W. REEVES,  
Assist.-Secretary.

### MEDICAL MICROSCOPICAL SOCIETY.

Friday, March 17, 1876.—Dr. F. Payne, President, in the chair.

*Hints on the Systematic Study of Histology.*—Dr. Bathurst Woodman read a paper on this subject, one great object of it being to recommend medical students and practitioners to study the microscope broadly; in other words, not to confine their studies to the dead-house or the dissecting room, or to the medical uses of the instrument, but to examine botanical specimens, furs, seaside objects, anatomical and pathological specimens from the lower animals, and in fact anything and everything they came across. Three or four fresh objects a day would make nearly a thousand a year.

The next point was an earnest recommendation to make a sketch or drawing (no matter how rough) of every object seen, either by the camera lucida or otherwise, and to preserve these drawings.

Thirdly, to study micrometry. A cheap micrometer made by ruling lines on paper was shown by the author, whose fourth recommendation was, Work economically. Some cheap forms of apparatus were mentioned in the paper. The use of low powers as a means of training the eye, not to supersede, but to precede, high powers; and the regular but systematic use of a few reagents were other matters insisted upon in the paper. Dr. Woodman concluded by strongly urging the formation of a library in connection with the Medical Microscopical Society, for reference, and perhaps loan. Towards this he would be happy to contribute a small sum, or some books, as a nucleus. The desirability of such a library was almost self-evident, since books on histology are for the most part either expensive, if recent, or comparatively scarce and inaccessible.

The President regretted the too little general use of the microscope, and that medical students had too little previous knowledge of natural history; and then—as in botany—high systematic work was often commenced at once, and the smaller but equally important plants neglected. Measuring and drawing he thought could not be too much insisted upon, and he fervently wished that instrument makers would provide a micrometer in lieu of much of the unnecessary apparatus usually placed in microscope cases.

After some further remarks from various members, the meeting resolved itself into a conversazione.

#### QUEKETT MICROSCOPICAL CLUB.

Ordinary Meeting, February 25, 1876.—T. Charters White, Esq., M.R.C.S., Vice-President, in the chair.

Mr. R. Packenham Williams described an improved form of freezing microtome, consisting of a wooden chamber, to the bottom of which is securely screwed a pillar with a spreading base and curved sides; to the chamber is fitted a turned lid with a plate-glass top, having a hole large enough to allow the end of the pillar to pass through; on the top of this pillar is placed the tissue in gum-water. The lid is removed, and the cavity of the chamber surrounding the pillar filled with ice and salt; the lid is then replaced, and in a short time the tissue, together with the gum-water surrounding it, is sufficiently frozen for making sections. The cutting is effected by a straight-edged razor attached to a triangular frame, supported by three screws; a delicate adjustment is effected by means of the screw at the apex of the triangle, instead of moving all the three screws, as in the American instrument. Means are provided for placing the razor parallel with the plate glass over which it moves, rendering the instrument efficient and easily managed.

Ordinary Meeting, March 24, 1876.—Dr. Matthews, F.R.M.S., President, in the chair.

Mr. N. E. Green made a further communication with reference to

his method of illumination by extremely oblique light, and exhibited some specimens of *Triceratium*, in which the small disks at the angles of the hexagons, usually seen as beads, were shown to be really depressions or "craters."

Mr. M. Hawkins Johnson, F.G.S., read a paper "On Silicified Structures in Pyritized Wood." A description was given of the fossil wood-stems found, at low water, on the north coast of the Isle of Sheppey, having been washed up out of the London clay. These consist principally of iron pyrites, and are used in the manufacture of sulphuric acid. On dissolving the iron pyrites by nitric acid, acting upon a smooth section, the woody structure, which appears to have become silicified, is left in relief. The conclusions drawn were that the silicification was due to the replacement of the carbonaceous walls of the wood-cells by silicon, and that the pyritous infiltration subsequently filled the pores of the structure.

Mr. Charles Stewart, M.R.C.S., &c., at the invitation of the President, gave a very interesting description of the hard parts of Echinoderms, which he considered to rank amongst the most beautiful objects claiming the attention of the microscopist. He enumerated the various groups into which the class was divided, and described their general characteristics. He then gave a detailed account of the *Echini*, figuring the typical forms, and minutely describing their anatomy, and the structure and arrangements of the spines, ambulacral disks, and pedicellariæ. Numerous specimens of the hard structures of Echinoderms were exhibited under several microscopes in illustration of the subject.

#### ADELAIDE MICROSCOPICAL CLUB, SOUTH AUSTRALIA.\*

The monthly meeting was held on August 20, 1875, Mr. Young in the chair. Mr. Babbage exhibited objects for polariscope. Dr. Whittell exhibited a thin section of a cancer of breast removed four weeks ago. The section had been cut so as to include a portion of the adipose tissue, and the interest of the preparation lay in the fact that the cancerous cells were just beginning to invade the fatty tissue. It was determined to hold a *conversazione* in September or early in October. Several members promised to assist, and it was recommended that, as far as possible, the members exhibit objects prepared by themselves, and of local interest. The Chairman then gave a short address on Pond-life, which he illustrated by objects brought from ponds near his residence. He said these would have been more numerous, but he found the season was not so far advanced as in former years, and many confervoid growths had not yet made their appearance. Among the objects of interest were several specimens of the Desmidiaceæ, a beautiful specimen of *Volvox* resembling the *Volvox globator* of England, but differing from it in a few minor details. A specimen of *Nitella* in which the circulation could be distinctly seen was also exhibited. This attracted the attention of members because many of them had failed to find in South Australia a plant in which the

\* Report supplied by Dr. Whittell.

circulation could be clearly observed. After the Chairman's address a few minutes were spent in comparing the scales of the *Lepisma* found in Australian houses with those of the *Lepisma saccharina*. The Australian *Lepisma* is commonly known as the silver eel, and is about an inch long. The scales are of precisely the same form and structure as those from England, but are from two to three times their size, and the markings on them are much more distinct.

The monthly meeting was held on September 17, 1875, Mr. T. D. Smeaton in the chair.

It was decided to hold a conversazione during October, instead of the usual monthly meeting. Several gentlemen promised to lend their assistance.

Mr. G. Francis exhibited crystals of aphidine, a fat he had succeeded in extracting from the *Aphis*. This when melted on a hot slide and allowed to cool formed a beautiful polariscopic object. Mr. Francis also exhibited diatoms from Turkey sponge, and a "Polar clock."

Mr. Young exhibited specimens of *Floscularia*.

The Chairman then gave a short address on the Polyzoa, dwelling chiefly on their characteristics and classification of such as are found along the South Australian coast. Numerous specimens were exhibited; amongst these were several varieties of *Catenicella*. The Chairman said he had met with at least ten varieties on the Australian coast.

The first public soirée given by this club was held on the evening of November 6, 1875, in the rooms of the Institute, which were kindly lent for the occasion. His Excellency Sir A. Musgrave, Governor-in-Chief, Lady Musgrave, several members of the ministry, and a large company of ladies and gentlemen, honoured the club with their presence, and manifested great interest in the instruments and objects placed on the tables for their inspection. The following is the list of exhibits:—Rev. J. Jefferis: Smith and Beck's binocular, with Darker's triple selenites; Field's dissecting and mounting microscope; and Highley's field microscope. Tissue and spicules of sponge (South Australian); skin and spicules of holothuria (Northern Territory Trepan).—Dr. Whittell: Powell and Lealand's large microscope, with binocular prism for high powers; Beck's large binocular; Nacet's portable microscope; Highley's hospital microscope. Immersion objectives: Powell and Lealand's  $\frac{1}{8}$  inch; Carl Zeiss's  $\frac{1}{8}$  inch; Möller's Probe-Platte; and suitable test-objects. Eye of beetle, showing through each of its lenses a separate image of the seconds' hand of a watch in motion; poison fang and duct of centipede (to illustrate new mode of preparing insect structures); anatomical and pathological specimens—muscular fibre; hard cancer, showing its earliest stage; epithelial cancer; glioma; *Trichophyton tonsurans* (from ringworm in scalp); scales of *lepisma* (Australian "silver eel"), shown by Wenham's method of reflex illumination.—Dr. Gardner: Beck's student's microscope; Möller's Diatomaceen Typen-Platte, containing 409 different diatoms, arranged in order in

a space of less than  $\frac{1}{4}$  inch square.—Mr. B. H. Babbage: Monocular microscope, with Collins' objectives. Crystals of salt; sulphates of iron, nickel, cobalt, copper, zinc, potash, and magnesia; acetate, nitrate, and superoxalate of potash; iodide of potassium; borate and muriate of soda; ~~muriate of ammonis~~; alum; sugar; citric, tartaric, and oxalic acids.—Mr. Mais: Collins' A 1 Harley binocular, with circular goniometer stage, revolving sub-stage, with centering adjustments; immersion lens,  $\frac{1}{10}$  inch; Webster's achromatic condenser; Brown's iris diaphragm; Abraham's achromatic prism; Maltwood's finder; Darker's revolving selenites; Jackson's micrometer eye-piece; and other fittings. In Blackwood cabinet of colonial manufacture. Fiddian's lamp; Horne and Thornthwaite's mounting table. Polarizing objects; salts of quinine; starch from Calabar bean; embryo oysters; human skin; plaited horsehair; gun-cotton muslin; mummy cloth; whisker of lioness; palates of whelk, limpet, snail, chiton, and ear-shell; gizzard of cricket. Möller's Diatomaceen Typen-Platte, No. 2; elaborate groups of diatoms, transparent and opaque.—Mr. G. Francis: Smith and Beck's educational; Browning's spectroscope; micro-spectroscope; direct-vision spectroscope. Tubes of fluids, showing absorption bands—didymium; uranium; cobalt; blood; chlorophyll; aniline dyes; cineraria; indigo; bile pigment; fish pigment. Metals in combustion, showing bright lines—potassium; sodium; lithium; thallium; barium; strontian; calcium; indium; cesium; rubidium. Absorption bands of selenite under polarized light.—Mr. J. R. Gurner: Powell and Lealand's monocular; Hartnack and Oberhäuser's monocular. Insects and insect structures found on the Eucalyptus.—Mr. J. G. Young: Harley's binocular, by Collins, with sliding objectives. Botanical specimens: cuticle of wheat, oats, &c.; spiral vessels; raphides; hairs of leaves; leaf of sphagnum; seed of *Paulownia imperialis*; seaweed.—Mr. C. W. Babbage: Smith, Beck, and Beck's binocular. Wings of butterflies; hairs of elephant, mouse, rat, human hair; feathers of humming-bird, goldfinch; wing-cases of diamond beetles; skin of sole; scales of eel, sole.—Mr. Calf: Beck's popular binocular, with Webster's condenser and Collins' parabolic reflector. Insect preparations: proboscis of butterfly, drone-fly, and blow-fly; antennæ of moth and blow-fly; foot of tabanus, blow fly, and spider; wing of house-fly, mosquito, and lace-wing fly; epidermis of beetle; oar of water-boatman.—Mr. Holmes: Crouch's student's histological monocular, with glass revolving stage. Polycystina; foraminifera; micro-photographs; sections of sugar-cane, gutta-percha, birch, lemon, *Monstera deliciosa*; sori of ferns; leaves; pollen; young oysters *in situ*.—Mr. Smeaton: Smith and Beck's popular binocular. Diatoms from 'Challenger'; parasites of native companion, canary, pheasant, bat, horse, pig; South Australian polyzoa, as opaque objects and by polarized light; blood-disks from mammals, reptiles, and fish; wings of South Australian butterflies and moths.

## SAN FRANCISCO MICROSCOPICAL SOCIETY.

Annual Meeting, February 3, 1876.—Election of officers resulted in the re-election of the old board of management, as follows:—President, Wm. Ashburner (who delivered an excellent address on the work done by the Society, and who deprecated the notion of publishing 'Transactions,' in the present state of the Society); Vice-President, Henry C. Hyde; Corresponding Secretary, Charles W. Banks; Recording Secretary, C. Mason Kinne; Treasurer, Charles G. Ewing.

Mr. Arthur Cottam read a paper upon a new *Aulacodiscus*, which had been brought from the west coast of Africa by Mr. Martin, an officer of H.M.S. 'Spiteful.' It had been considered to be a variety either of *A. Kittoni* or *A. Johnsoni*; and after describing the characteristic features of each of these species and of the new diatom, Mr. Cottam expressed an opinion that the new form was in some respects so distinct from either, that it might well be made a distinct species, for which he suggested the name of *Aulacodiscus Africanus*.

Mr. N. E. Green read a paper upon a new stage arrangement for the examination of objects either by reflected or transmitted light, and exhibited a slide of *P. angulatum* under a  $\frac{1}{15}$ th by Zeiss, illuminated entirely by side light. The silvery appearance of the object, contrasted with the grey background, was very beautiful, and the definition extremely sharp. Mr. Green also remarked upon the advantages of side illumination in the observation of the surface markings of diatoms; and exhibited *Triceratium* and *Isthmia* under a  $\frac{1}{12}$ th by the limelight, as examples of very oblique reflected illumination.

## FAIRMOUNT MICROSCOPICAL SOCIETY OF PHILADELPHIA.

The regular monthly meeting was held May 20, in West Green Street. The subject of the evening was *Micro-fungi*. The Secretary, Mr. Stevenson, read a paper on the subject, and illustrated it with a series of slides of æcidium, puccinia, aregma, triphrogmium, uredo, ustilago, tuchobasis, &c. Drs. Griffith and Shakespeare opened a very interesting debate on the subject of "the fungoid origin of disease," which was freely discussed by Dr. James, Mr. Gray, and the other members present. The evening was spent very profitably to those present, and was pronounced by all to be one of the most enjoyable held during the year. A vote of thanks was unanimously tendered Mr. D. S. Holman for his fine exhibition of the gas microscope at the meeting in February.

This Society grows in interest and numbers, and is fast becoming a permanent organization.

[www.libtool.com.cn](http://www.libtool.com.cn)



Gnat's Body Scale  
from a drawing by  
Dr. Anthony.

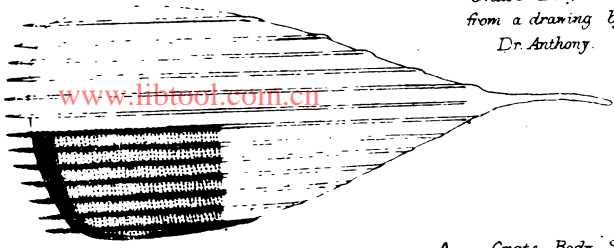

A. Gnat's Body Scale  
from a photograph by  
Dr. Woodward. \*1350.

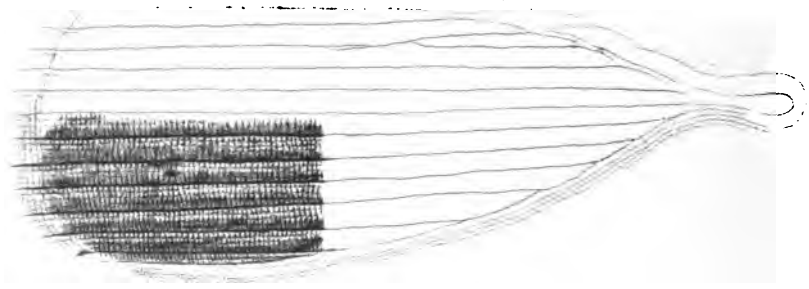

B a smaller Scale  
\* 1500.

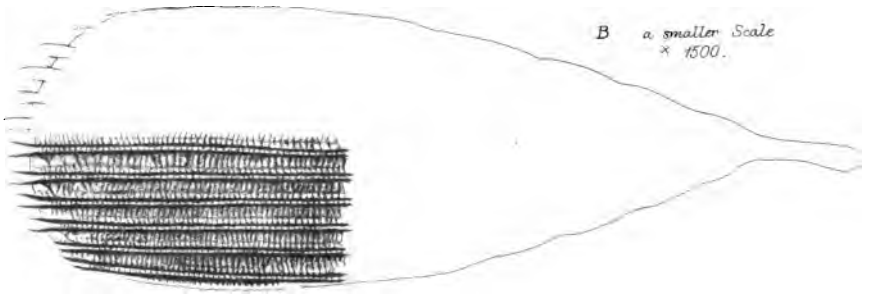

C. id.

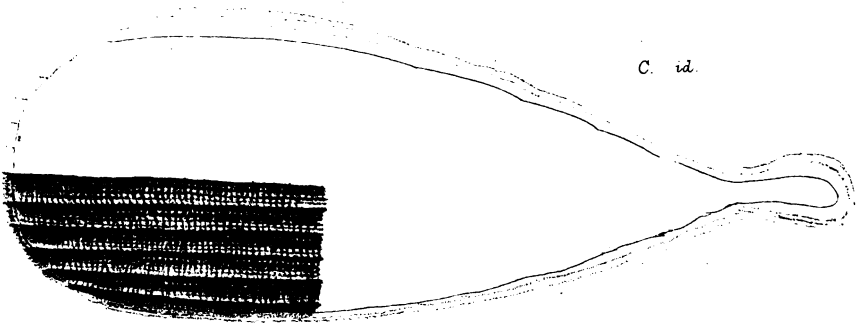

[www.libtool.com.cn](http://www.libtool.com.cn)

D. *Mosquito Edele*  
from a photograph  
by Dr Woodward.

× 1350

[www.libtool.com.cn](http://www.libtool.com.cn)

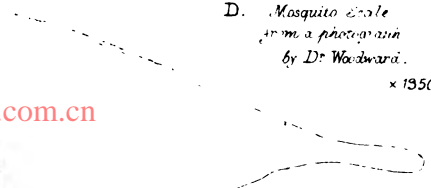
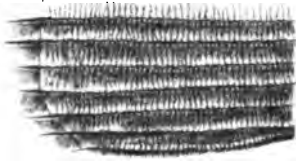

E. *id.*

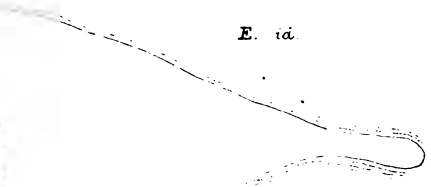
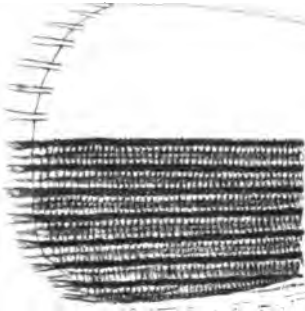

F. *id.* × 1300.

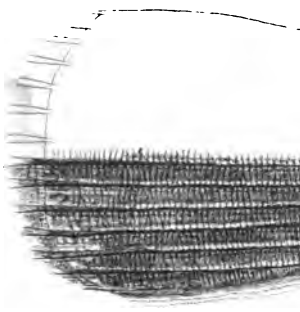

G. *id.* × 1350.

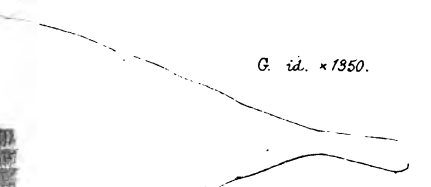
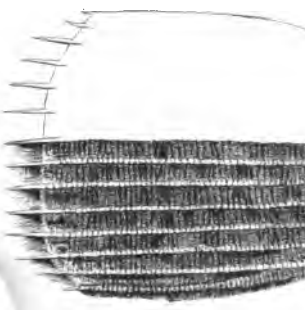

THE  
MONTHLY MICROSCOPICAL JOURNAL.

www.libtood.com.cn  
JUNE 1, 1876.

I.—*On the Markings of the Body-scale of the English Gnat and the American Mosquito.*

By Dr. J. J. WOODWARD, U. S. Army.

(Read before the ROYAL MICROSCOPICAL SOCIETY, May 3, 1876.)

PLATES CXXXIX. AND CXL.

My attention was first directed to the markings on the body-scales of the English gnat by a letter received last summer from Mr. John Mayall, jun., enclosing a mounted slide of these scales, and a photograph of a drawing of one of them by Dr. John Anthony, of Birmingham, representing the scale as *marked by longitudinal beaded ribs, having three uniform parallel rows of smaller beads in every interspace between two adjoining ribs.* (See Pl. CXXXIX.)

Mr. Mayall stated that Dr. Anthony had made the drawing to represent an appearance of the scale glimpsed by central light, but had not been able to show this appearance to him in the microscope as definitely as it appears in the drawing, and requested me to undertake to photograph the scale as seen under the microscope. This I did at such leisure hours as I was able to command during the latter part of last year, and in so doing arrived at results which may perhaps be of interest to some of your Fellows.

I at once observed the very great similarity between the scales of the English gnat and those of the American mosquito, with which I had been familiar for a number of years; a similarity which relates to all the details of surface markings, as well as to the size and general outlines of the scales. In the case of the mosquito, I had seen that the scales are crossed transversely by fine markings, probably ridge-like corrugations of the thin double membrane composing them, and that these transverse markings crossing the longitudinal ribs at regular intervals, gave to the latter a beaded appearance; but I had not believed that the transverse markings were also beaded. I must add that the ribs and transverse markings exist on both surfaces of the scale, though much more boldly on one than on the other, and that the longitudinal ribs of the opposite sides unite at the broad end of the scale, where they generally project as bristle-like appendages beyond the general contour.

My examination of the slide received from Mr. Mayall has led

me to the opinion that this description applies to the gnat scale as well as to the mosquito. Nevertheless, on examining a gnat scale, as requested by the donor of the slide, with the immersion  $\frac{1}{8}$ th of Powell and Lealand, by central illumination, I succeeded, after some trying with the right-angled screws of the achromatic condenser, in obtaining, as I suppose, the very appearance Dr. Anthony's drawing is intended to represent, and the three parallel rows of minute intercostal beads started out suddenly into view between each pair of longitudinal ribs over the whole surface of the scale.

This appearance was so realistic that at first I inclined to the opinion that it represented truly the actual markings of the scale, and accordingly I endeavoured to photograph it as requested, with the objective named, by monochromatic sunlight, and after several failures succeeded in obtaining a fair representation of what I saw. I send herewith a print (marked A) from the resulting negative.

I have, however, since then been led to form the opinion that these clearly seen beads are a spurious appearance, produced by longitudinal diffraction lines, conditioned by the longitudinal ribs and parallel to them, which cross the true transverse markings at right angles, and thus give rise to the optical appearance of beads at the point of intersection; the whole series of phenomena being similar in character and origin to the diffraction phenomena observable in many diatoms, &c., as described by me in my "Note on the Markings of *Frustulia Saxonica*" in this Journal, December 1875, p. 274.

My chief reasons for this opinion in the present case are—firstly, that the longitudinal diffraction lines are clearly seen, both in the microscope illuminated by lamp or sunlight, and in the photographs (as, for example, in the print A) to extend into empty space beyond the contour of the scales almost as far as the ends of the bristles in which the parallel ribs terminate; and secondly, that they vary in number with varying obliquity of illumination, so that in the same scale two, three, four, or five rows of beads can be seen, and photographed at pleasure, in each intercostal space.

Since arriving at this conclusion I have had no difficulty in producing at will, either the beaded appearance, or that which I conceive to represent correctly the surface markings, on any scale I have tried, whether of the gnat or mosquito.

If the selected scale is illuminated with the light thrown perpendicularly to the transverse markings, by means of an Abraham's prism, the beaded ribs and smooth transverse markings will be clearly shown; and if now the stage be rotated so as to turn the long diameter of the scale more and more obliquely to the illuminating pencil, the spurious lines, and with them the beads, will start into view; the number of spurious lines, and consequently

the number of rows of beads, varying with the angle of the illuminating pencil. Or the true appearance may be produced by the achromatic condenser adjusted so that the light is either truly central, or slightly oblique in the direction of the length of the scale; and then a very moderate degree of obliquity in the illumination transversely to the scale, obtained by means of the right-angled screws of the condenser, will bring out the rows of beads, varying in number as in the former case, in accordance with the degree of obliquity attained.

I submit these results without further comment at the present time, with a few additional photographs intended to represent some of the chief appearances obtained. Two of these pictures, in addition to that mentioned above, are from the slide of gnat scales sent by Mr. Mayall, and are taken with the immersion  $\frac{1}{8}$ th of Powell and Lealand; the others represent a mosquito scale as seen with an immersion  $\frac{1}{8}$ th, constructed for the Museum by Mr. Tolles, of Boston. I selected for this series a different lens from that used for the gnat scales to show that the diffraction appearances discussed in this paper result from the optical conditions under which the scales are viewed, and not from any peculiarity in the objectives of any particular maker.

In conclusion, I would refer those who desire preliminary information as to the character and distribution of the gnat scales to the paper by Mr. Jabez Hogg, "On Gnat Scales," in this Journal for October, 1871, p. 192; or to his work on the Microscope, the first edition of which was published in 1854. The description there given of the various forms of gnat scales, and of their distribution on the insect, is very nearly accurate for the mosquito also.

*List of Photographs.*

- A.—Gnat scale, showing three rows of intercostal beads. Magnified 1350 diameters by Powell and Lealand's immersion  $\frac{1}{8}$ th. (Neg. 771.) See Pl. CXXXIX., Fig. A.
- B.—A smaller gnat scale, showing smooth transverse markings. Magnified 1500 diameters; same objective. Achromatic condenser; central light. (Neg. 781.) See id., Fig. B.
- C.—The same scale, with same objective and power, but moderate obliquity of illumination obtained by means of the right-angled screws of the condenser. (Neg. 782.) See id., Fig. C.
- D.—Mosquito scale, showing smooth transverse markings. Magnified 1350 diameters by an immersion  $\frac{1}{8}$ th of Tolles. Achromatic condenser; nearly central light. (Neg. 765.) See Pl. CXL., Fig. D.
- E.—Same scale, same objective, but light oblique laterally as well as transversely, showing two rows of beads in each intercostal space. 1350 diameters. (Neg. 768.) See id., Fig. E.
- F.—Same scale, &c., showing three rows of beads in each intercostal space. 1300 diameters. (Neg. 778.) See id., Fig. F.
- G.—Same scale, &c., showing four rows of beads in each intercostal space. 1350 diameters. (Neg. 766.) See id., Fig. G.

*Note by John Anthony, M.D.*

Having read Dr. Woodward's paper on the gnat and mosquito scales, and looked carefully at the set of photographs in illustration, which that gentleman has had the kind courtesy to forward to me, I can come to no other conclusion but that what I have hitherto regarded as real bead markings on the membrane in the intercostal spaces on the scales from the body of the gnat are really and truly spurious images, or, in the words of Dr. Woodward, "diffraction appearances."

Some two years ago, in the examination of a large number of gnat scales, principally with the fine  $\frac{1}{4}$ th and  $\frac{1}{8}$ th objectives of Messrs. Powell and Lealand, such results were obtained that I thought I had found in the scale from the *body* of the gnat an excellent test for the "definition" of high-power objectives, inasmuch as there seemed, with moderately oblique and well-corrected light, what appeared to me triple rows of clearly defined beads between the beaded longitudinal ribs of the scale; and, as the same appearances of beads were always manifest, and as those beads always seemed to come out clearer when viewed with objectives of well-known excellence, I trust to be pardoned for believing that what I saw were not only real appearances, but that such objects as the gnat scales might be of the greatest service to the microscopist as tests for the defining qualities of high-power objectives. Under such impression I made a careful drawing of the markings on the gnat's scale under the most favourable conditions, and that drawing I copied by means of photography; the photograph would have been made directly from the scale of the gnat itself, but I had no heliostat. These photographic copies of the drawing have gradually passed into the hands of one or other of my microscopical friends until the specimen forwarded with this paper is the only one left to me. However, I have the negative, and if possible impressions shall be printed for distribution among the members present at the next meeting of the Society.\* (Pl. CXXXIX.)

Taking the E, F, and G photographs of Dr. Woodward to be the most characteristic, inasmuch as they show respectively two, three, and four rows of beads as seeming to exist upon the same scale under different conditions of illumination, I think one can only look upon my drawing as a representation of very clearly seen spurious beads. Of course it is not very flattering to one's *amour propre* to have it shown so convincingly that one has taken the shadow for the substance; but I am assured that I shall have erred in good company, inasmuch as the analysis of these diffraction images will strike at the root of a vast number of descriptions of

\* Some were sent by Dr. Anthony to the meeting.



quasi beaded tissue seen in all sorts of objects examined with high-power lenses.

This brings me naturally to the observation that I think microscopists, who are not too proud to learn, owe to Dr. Woodward a debt of gratitude for the trouble he has taken, and the skill he has displayed, in teaching us the precautions we ought to take in high-power investigations to distinguish between the false and the true. I have worked long enough at the microscope to feel that as a rule one ought, like the late Lord Eldon, to "doubt" everything; and have often amused myself in producing, on well-known diatoms, a series of permutations of "diffraction phenomena," and therefore can appreciate most fully the truthful excellence of Dr. Woodward's article and illustrations in the December number of the 'Microscopical Journal.' I regard these papers on spurious appearances as among the most valuable contributions to microscopical literature. Dr. Woodward points out that detail, however clearly seen upon a scale, may be more than suspected of being unreal if it seems not to be confined to the limits of the scale or shell itself, but to "pass off into space." A question arises as to how you are to deal with the appearances, such as a fairly careful observer might get, and such as I myself observed on the gnat's scale, where there was no projection of the image into space; a phenomenon with which, as I stated, I am very familiar. The only suspicious point noticed was an apparent alteration in the character of the detail on revolution of the object, but the employment of light more or less oblique has in most cases, and particularly in very diaphanous objects, accustomed one to look at certain scales always in the same position with respect to the plane of the illumination as being "best seen"; and it is to be feared that very many of us, in our employment of the microscope, are apt to be led away by beauty of image.

It appears to be clear that no perfection of "condenser," and no superior quality in the objective, can save us from acquiring erroneous impressions of what we see in the microscope, if we have not a very distinct notion of the "pitfalls" which await us in the shape of diffraction images. Dr. Woodward evidently has grasped this difficult subject with a master hand; he has used photography as a witness—which to me is most satisfactory; he has given us a most valuable lesson, and I for one beg to thank him for it.

WASHWOOD HEATH, BIRMINGHAM,  
April 3, 1876.

---

II.—*Notes on Micro-photography.*

By Surgeon-Major EDWARD J. GAYEB, H.M. Indian Army, now  
Professor of Surgery, Medical College, Calcutta.

(Read before the ROYAL MICROSCOPICAL SOCIETY, May 3, 1876.)

## PLATES CXLI AND CXLII.

THE best micro-photographs can of course only be produced by the best objectives; but besides this many things are required, and as much as anything else, good manipulation. You may have a very good light and the most perfect form of apparatus, and yet, from want of sufficient control over all, really good work may not be the result of the expenditure of much labour and time. It is manifest that the best position for the operator during the whole manipulative process (except of course the photographic part of it) is near the microscope condenser, mirror and source of light, and not far away from all this apparatus at the focussing screen and dark slide. To be able to stand in a comfortable position within easy reach of your microscope and the other apparatus, and to be able to view your focussing screen and sensitive plate, watching the light, and altering it if you wish it at any time during the process, affords great facility to the worker. All this can be readily accomplished by the use of a small telescope, and with its help a very small quantity of special apparatus is required. The writer has worked for many years with the form of apparatus figured in Pl. CXLI., which consists of a common, heavy, strong table A, about 12 feet long and 2 feet wide. At one end of this table the mirror D is placed near enough to the source of light B and the cell for cutting off heat rays C, to allow of all being easily reached even when the eye is applied to the telescope N. The condenser E, the microscope F, with its condenser H, its object-glass G, its stage and fine and coarse adjustments, are all close together within easy reach of both hands all through the process. The focussing screen L and dark slide are at the other end of the table, and are made movable so as to slide up and down on the ledge O, in order that the distance between them and the micro-

## EXPLANATION OF PLATE CXLI.

- |  |  |
|--|--|
| A. Strong heavy table.                 | I. Mirror of microscope turned aside.      |
| B. Round hole for light.               | J. Cone connecting microscope with camera. |
| C. Cell for abstracting heat rays.     | K. Camera.                                 |
| D. Mirror and stand.                   | L. Dark slide.                             |
| E. Condenser and stand.                | M. Piece of thick white cardboard.         |
| F. Microscope.                         | N. Telescope.                              |
| G. Object-glass.                       | O. Slide for back of camera.               |
| H. Achromatic condenser of microscope. | P, P. Diaphragms.                          |

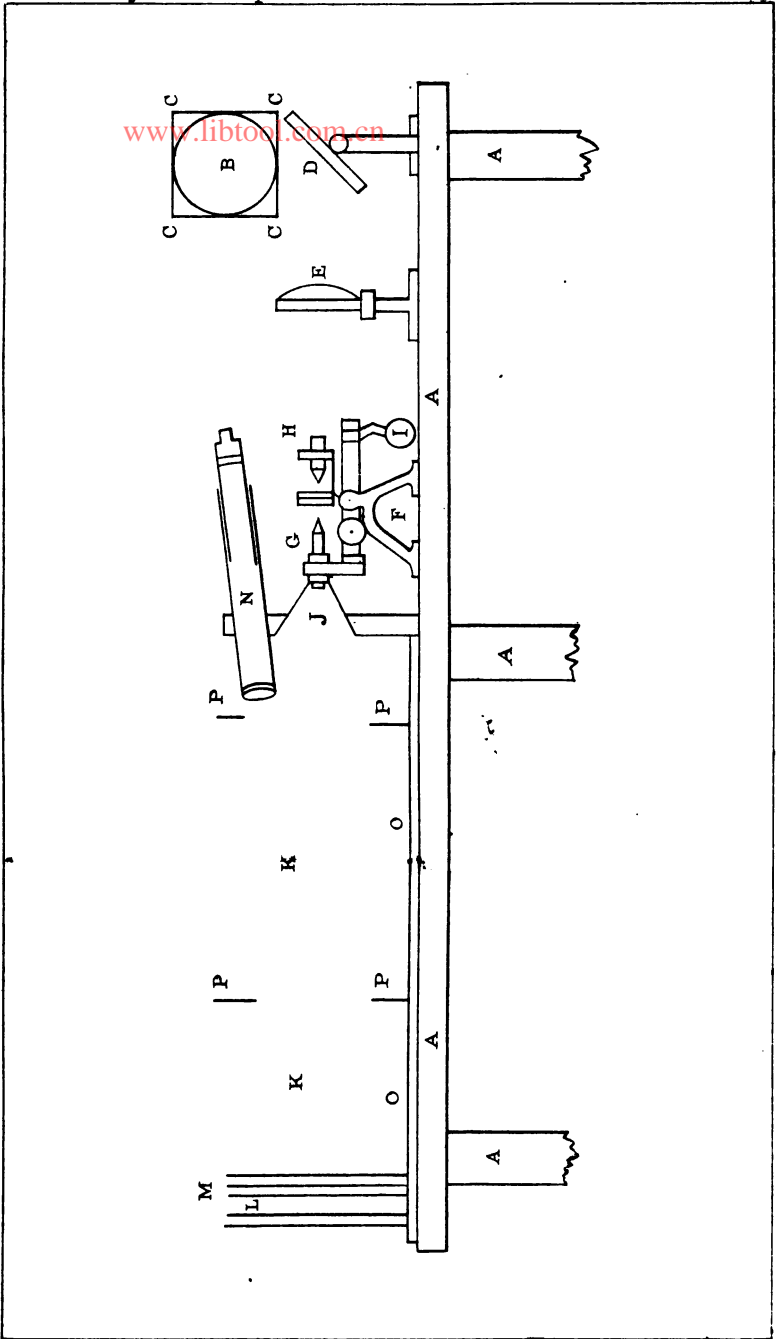

[www.libtool.com.cn](http://www.libtool.com.cn)

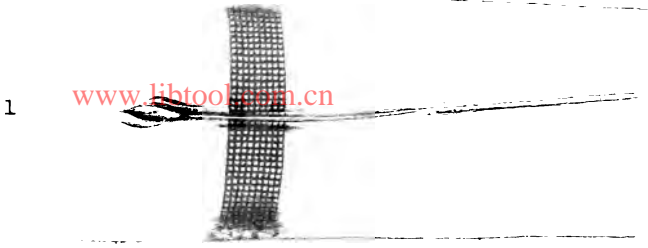

*Pleurosigma Balticum.*

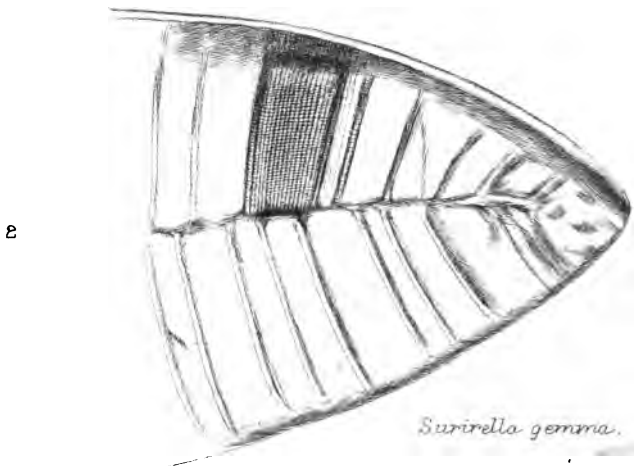

*Surirella gemma.*

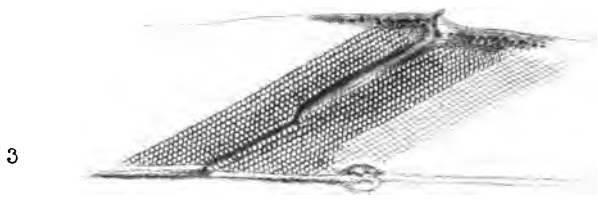

*Pleurosigma strigosum.*

[www.libtool.com.cn](http://www.libtool.com.cn)

scope may be altered at pleasure. The mode of procedure is as follows. Uncover the round hole B, the source of light (if sunlight is used, this hole, together with the rest of the apparatus attached to it, should have a vertical movement to allow for the changing position of the sun), and place in front of it either an ammonio-sulphate of copper or alum cell, or a piece of blue glass, according to the work you are going to do. Adjust the mirror D, which is best made of silvered glass with the polished silvered side up, and connected with a ball-and-socket joint to a firm but movable stand on the table. Place the large condenser in the path of the rays as close to the mirror as may be convenient, and at such a distance from the microscope that the rays of light shall cross before entering the achromatic condenser of the microscope. This large condenser E should be an achromatic lens, of moderate focus, and as large as possible, not less than 3 inches in diameter, and not more than 10 or 12 inches focus. A photographic landscape lens answers well. Adjust the achromatic condenser of your microscope, the object, stage, and objective. Place your dark slide open in the holder at the other end of the table with an unprepared plate in it, on which you have previously evenly pasted a piece of white albumenized paper, and on which you have drawn two diagonal lines from corner to corner of the plate, in order to show its centre, and on which at the centre you have either neatly written or pasted a word in small type. Adjust your telescope N so as to view this word in perfect focus, and then leave it so. This telescope is best made out of the object-glass of a large opera-glass and the eye-pieces of your microscope, by connecting the two with tubes of sufficient length to allow of considerable throwing back of the conjugate focus of the object-glass, a necessary result of your viewing the plate at a distance of a few feet and your telescope object-glass receiving divergent instead of parallel rays. Then still looking through the telescope, which is a fixture, being made to slide stiffly through a hole in the fixed front of the camera K, focus with the fine and coarse adjustments of your microscope, and bring the object into its proper place on the screen of albumenized paper, the centre of which is abundantly apparent owing to the word and the cross lines, and is a very easy substance to focus on. Having made all adjustments, remove your dark slide with the focussing screen in it, shut the hole B by a shutter from outside the window worked by cords. Prepare your sensitive photographic plate, with which you replace the plate covered with albumenized paper, and put the closed dark slide into the place where you took it from, and put a piece of white cardboard M into the groove close in front of the dark slide; open the shutter and arrange the light finally on the cardboard. Place a book or other shield in front of the large condenser E in the path of the rays, so as to shut off the



light; remove the cardboard M, lift the shutter of the dark slide and expose the plate, watching the process through the telescope, and if the exposure is a long one altering anything that may appear necessary, for many beautiful results may be obtained at this stage of the proceedings by altering the light during the exposure. For instance, to mention one which will be at once self-obvious, an object can be exposed first as an opaque specimen and then as a transparent one on the same part of the plate, thus bringing out the surface markings as well as the transparent outlines. The microscope tube and the eye-pieces may be used with the telescope as they should never be used with the microscope in micro-photography as they contract the field and blur the image, magnifying power being better obtained by distance, which with this apparatus may be anything from 2 feet to 8 feet or more if the table is made long enough. The microscope should be connected to the camera by a cone J, which may be made of tin, paper, or any suitable material. The camera is best made quite open, as shown in the Plate, a cloth being thrown over it supported by the ends and the diaphragms P, P, which are very useful to cut off light not required to form the picture. They should be so arranged as not to interfere with the telescope, and may have holes cut in them for this purpose if necessary. A sufficiently strong eye-piece should be used in the telescope to give a clear view of the minutiae of the specimen, so that a very perfect focus may be obtained. Your hands are the best heliostat, as the mirror is within your easy reach the whole time. Instantaneous micro-photography should be attempted with no objective of a higher power than half an inch, and the large condenser only should be used. The alum or other cell should also be removed at the time of exposure. A special shutter will also be required between the large condenser and the object to be photographed. This shutter should have no connection with the table, as it would communicate a vibration to the whole of the apparatus at the moment when everything should be perfectly still except the movements of the animalcule you wish to photograph. A good shutter for this purpose can be made with two boards having round holes cut in them and made to slide one over the other, an india-rubber band being the motive power. In this way one hole may be made to pass the other with such speed that the exposure is absolutely instantaneous, and the portraiture of rapidly moving subjects rendered perfectly easy with a good light. The writer has done many in this way.\* When the higher objectives are used, such as the  $\frac{1}{8}$ th, they are generally better used on the immersion principle, and glycerine or oil of cassia may be used instead of water. When substances with a higher refractive index

\* Copies of some of these instantaneous micro-photographs may be seen in the Indian Museum, London.

than water are used, the focal distance between the objective and the glass cover will be increased, and the screw-collar must be adjusted accordingly to suit the more refractive medium in which the objective has been immersed. When oil of cassia is used (the substance chiefly used by the writer), which has a refractive index as high as 1.405, the screw-collar should be used so as to close the combination completely; with this latter substance it will be found quite possible to focus through rather thick covering glass. The view I have obtained, with the help of the oil of cassia, of various objects has been very satisfactory. Both the longitudinal as well as the transverse striæ on *Frustulia Saxonica* may be made out fairly. (Pl. OXLII.) The longitudinal striæ are at the same distance apart as the transverse. I think, from the help I have obtained in this way, and from various experiments I have made, that the markings on at least most of the diatoms are neither elevations or depressions, but are holes, the line of fracture always passing through these holes in the same way as it does through the perforations round a postage stamp. Diffraction and interference phenomena are so deceiving and perplexing, and look so real, that even photographic proof, as it is sometimes called, goes for very little; but I hope on some future occasion to be able to offer satisfactory proofs of the statements I have here made, and regret much that press of time prevents my doing so now.

---

III.—*On Renulina Sorbyana.* By J. F. BLAKE, F.G.S.

(Read before the ROYAL MICROSCOPICAL SOCIETY, May 3, 1876.)

TWENTY years ago Mr. Sorby noticed some remarkable bodies in the lower calcareous grit of Scarborough, which he described in a paper read before the Geological Society. These bodies were for the most part agatized, as are most of the shells in the same deposit. He described them as reniform viewed on the side, and oval as seen behind, their size being on the average  $\frac{1}{100}$  inch. In spite of their metamorphosed state, some gave signs of having been originally hollow, because a line of dirt parallel to the outside surface could be traced within. He sums up his observations thus: "These facts, I think, indicate that these bodies were small shells. . . . Nevertheless, I will not insist on this view, for I have found cases where the impurities were not arranged as if there had been a shell, though not in a manner irreconcilable with that supposition. . . . They may perhaps have been Foraminifera, although I have not been able to detect any internal divisions into chambers, nor anything to indicate that they are detached foraminiferous cells."

Since that time no such bodies have been observed elsewhere, and no further light has been thrown upon their nature.

On examining the washings from some rubbly clay beds associated with pisolite occurring at Sturminster Newton, in Dorsetshire, near the base of a series of strata representing the coralline oolite in time, and a little more recent than the lower calcareous grit of Scarborough, I was surprised to find the material crowded with such minute reniform bodies, which a comparison with Mr. Sorby's description and afterwards with his specimens themselves, left no

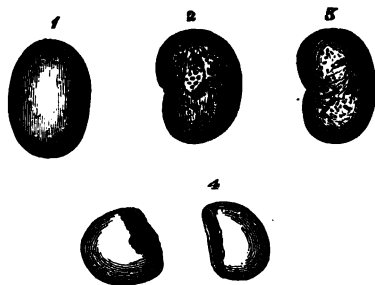

*Renulina Sorbyana*  $\times 100$  diam.

- FIG. 1.—View from behind.  
 ,, 2.—Side view of a specimen, showing in parts an outer layer on the surface with areolate ornament.  
 ,, 3.—Side view of another, in which small perforations of the shell appear.  
 ,, 4.—A broken specimen, showing the shells are hollow.

doubt of their being the same. These new examples settled one question with certainty. There could be no longer any doubt that they were originally hollow, for these were easily broken by pressure, and then presented their two empty halves, like a broken egg-shell, as plainly as possible.

Another point less doubtful before was also proved, namely, that they had been originally calcareous, because these are so. Silix may replace carbonate of lime, as it had done in the specimens from Filey, but the process cannot well be reversed. I conclude therefore that these Sturminster specimens are in their original condition. Acidulated water appears, however, to have had access to them, as their surfaces are eaten away and more or less rugged. This perhaps suggested the idea which my friend Professor Rupert Jones kindly favoured me with, that if Foraminifera, they might belong to the *Saccamina* group. Treated with hydrochloric acid, they certainly leave a small residue, which, however, appears to be structural silix and not grains of sand. The presence of such a residue would certainly not prove them to be arenaceous Foraminifera, for the undoubted Dentalines, Marginulines, &c., of the same deposit also leave a small residue, while the true arenaceous forms are almost if not entirely untouched. I have been fortunate, however, in being able to obtain what I think to be further evidence of their structure and nature. In a deposit of clay at Hilmarton, near Calne, Wilts, belonging to the uppermost portion of the corallian beds, and therefore of very similar age to the former deposit, I found a few among the ordinary Foraminifera of the washing which appear to have undergone but little change. These, however, do not make up the bulk of the microzoan fauna as at Sturminster and Scarborough, but are rare in comparison. Like the others, they are hollow and dissolve in hydrochloric acid, but their surface is less destroyed. As they now are, they appear to have two layers, an external one more opaque, which is mostly broken away, and an internal one more transparent. The external coat appears to me not to belong to the original shell, but to be a subsequent deposit. However, in some it presents in places an areolated structure, that is to say, is dotted over quincuncially by little pits. The internal layer shows, as I think, a foraminated structure like the shells of Rotalines; but as the appearance is by no means distinct and cannot often be seen, I confess it might be more satisfactorily demonstrated. In some these foramina seem to be limited to the neighbourhood of certain lines forming a pattern on the shell, and not to be uniformly scattered over the surface. The areolation of the external layer when present is more certain, and my idea of its meaning is that the calcareous matter has collected on the interspaces between the true foramina below, making these latter more conspicuous, though in some places it has covered foramina

and all. If I have rightly interpreted the appearances to indicate foramina at all, then of course the nature of these bodies is settled. What else can the appearances be due to? The action of polarized light has something to say about this. Seen in this way, the shell is divided into a number of compartments separated by irregular lines. These lines, then, seem to be cracks, or the boundaries of irregular crystallization; at least there is nothing in the appearances to prove they are not, and the whole shell seems so altered by metamorphic crystallization as to render it doubtful how far any specimen shows the original structure. One specimen, in which the whole interior was filled with black dust, showed little perforations of the shell, but they were so irregular and of such various sizes as to make it as likely as not they were due to metamorphism rather than structure. We are therefore cautioned that anything but what cannot possibly be other than true structure may possibly be due to some subsequent alterations, and therefore be deceptive. Nevertheless, their behaviour under polarized light is very similar to that of Foraminifera, and it would be, I think, difficult to prove most of the fossil Foraminifera such by the demonstration of their foramina, only we do not attempt it because we recognize them by their shape.

In the present case we do not recognize the shape, but there is nothing in it to prevent their being Foraminifera. They have only one cell, no partition occurring inside. They have no large aperture, but neither has the *Orbulina* or the *Globigerina* in the majority of cases. The general resemblance, in fact, of these shells in point of structure to that represented by the fossil *Orbulinæ* in similar strata, inclines me strongly to the belief that the foraminiferal interpretation is the right one, that they belong to the perforate group, and should be placed near the last-named genus. They have a general resemblance in shape to the *Noctiluca*, and the lines on their surface which are distinguishable in most, if they be not due to crystallization renders the similarity greater; but besides this, no organism that I can think of gives any example of such a form.

I take them, therefore, to be a peculiar form of Foraminifer, very characteristic of corallian strata, and would propose to name them *Renulina* from their shape, and for a specific name *Sorbyana* from their original discoverer.

---

IV.—*Remarks on Frustulia Saxonica, Navicula rhomboides, and Navicula crassinervis.* By CHARLES STODDER, U.S.A.

(Read before the ROYAL MICROSCOPICAL SOCIETY, May 3, 1876.)

As there seems to be much uncertainty prevailing in regard to the three species named above, I will attempt to clear the matter up. To do this it is needful to refer to the original descriptions, aided by the light of the most recent classification. Ralfs—Pritchard's 'Infusoria,' p. 924, 1862—gives the generic character of *Frustulia* (Ag.), "Bacillar immersed in an amorphous gelatinous substance;" *F. torfacea* (Braun), "Rhomboid lanceolate, with obtuse apices, stout median rib, and small central nodule;" *F. Saxonica*, "Slender than *F. torfacea*, valves more acute, front view linear, with broadly rounded ends." These are unquestionably the original descriptions of the authors. But Professor H. L. Smith (than whom there is no better living authority), "Conspectus of the Families and Genera of the Diatomaceæ," 'The Lens,' Chicago, 1872, rejects as a generic distinction the mode of growth, and consequently the whole genus *Frustulia*. Except the mode of growth there is no one character or combination of characters to distinguish *Frustulia* from *Navicula*. Mr. Hickie, this Journal, p. 127, No. lxxxvii., confesses "that he is unable to state where *Frustulia Saxonica* ends and our *small rhomboides* begins." In this he only confirms what diatomists have known for the last ten years. Now what is *N. crass.*? Wm. Smith, 'British Diatomaceæ,' 1852, gives *N. crassinervis* Breb., "Valve elliptic lanceolate, extremities produced, striæ obscure, length .0013" to .0026." *N. rhomboides*, Ehr., "V. nearly quadrangular, striæ very faint parallel, .85" to .001."\* There is nothing to distinguish one from the other, except the produced extremities of *N. crass.* Now that is such a trivial distinction, so far within all known and all but universally acknowledged variations of other species, that probably no student of these plants would at this time make use of it as a specific character.

But this is not all; Prof. H. L. Smith now owns all of De Brebisson's material. Since this discussion commenced Prof. S. has sent to me prepared from that material a slide of "*Nav. rhomboides*," and one of "*N. crassinervis*," with the comment that he could "see no difference between them." After a careful study of both slides I fully concur with Prof. Smith's conclusion. Neither Dr. Woodward's *photographs* nor the *lithograph* copy of Seibert's photograph show any specific distinction.

\* *Navicula rhomboides* in all its varieties is found throughout New England, but its head-quarters seem to be in the little ponds and streams among the white mountains of New Hampshire. There is one deposit on the bottom of Bennis Lake (see Lewis, in 'Proc. Phila. Acad. Nat. Sciences,' 1865), every slide of which will contain hundreds of frustules of all sizes. I have measured them from .0007" to .0017", varying in closeness of striation nearly in proportion to the size. Of course, as I consider the three names belong to but one species, I must believe that all of them will show longitudinal striation.

V.—*On the Measurement of the Angular Apertures of Object-glasses.* By JABEZ HOGG, Surgeon to the Royal Westminster Ophthalmic Hospital, F.R.M.S., &c.

I AM led to infer from what has recently transpired that considerable misapprehension prevails with regard to the measurement of the angular aperture of object-glasses. An article contributed by Mr. Ingpen to the Journal of the Quekett Club, and quoted in the 'M. M. J.,'\* though of some interest, only very briefly alludes to the various methods employed during the last quarter of a century, and does not touch upon any method that would be considered valid in the determination of the apertures of immersion lenses. Mr. Ingpen makes particular mention of Professor Robinson's method, and though he speaks of it as "a very elegant method, and likely to be valuable, in certain disputed cases, as to the true angle of immersion lenses," it would appear that he thinks immersion apertures can be measured by this method without any modification. It is, however, quite evident that Professor Robinson had solely in view the measuring of the apertures of dry lenses—such as have a true air-focus; and Mr. Ingpen offers no evidence whatever that he realizes what modification is necessary in Professor Robinson's method to render it applicable to immersion lenses.

In the Journal,† Mr. Wenham unhesitatingly affirms that Professor Robinson's method is by far the best. These are his words: "I consider that the most correct of all [methods of measuring apertures] is that proposed by Professor Robinson, which consists in passing the parallel rays of the sun through the back of the objective, and then by means of a white screen in a dark room intercepting the rays as a disk of light. The angle taken from the diameter of this to the focal point will give the true aperture." Mr. Wenham also appears to think that the aperture of immersion lenses can be accurately determined by the same method, and without modification of any kind. On the other hand, it is held by competent authorities who have given the subject special attention, that the only possible way of measuring immersion apertures with accuracy is to measure the angle of the cone of rays while they are in the condition of immersion. This view is entertained by Dr. Woodward, Professor Keith, Professor Abbe, Messrs. Hartnack and Prazmowski, Messrs. Powell and Lealand, Mr. Dallmeyer, Mr. Tolles, and Professor G. G. Stokes, whose authoritative utterances on the subject are of the highest importance.

The modification required in Professor Robinson's method to enable anyone to measure immersion apertures is an extremely simple one, and can be readily put into practice. In place of the white

\* Page 236, May 1876.

† 'M. M. J.,' vol. viii., p. 233.



screen, a cube of glass greyed on the under surface should be so placed that the lens may be accurately adjusted and focussed on the upper surface in water contact, or still better, in glycerine. The angle can then be read off the luminous disk on the greyed surface, by applying a suitable tangent scale. I have some idea that Mr. Wenham first proposed a cube of glass for measuring apertures, but have been unable to verify this, although I feel sure that the lenses so measured were dry lenses only. No true aperture can be measured unless the lens is so adjusted as to give its best and finest definition; it is therefore utterly fallacious to attempt to measure the aperture of an immersion lens unless it is adjusted for and actually measured in immersion contact. It would be quite as fallacious to attempt to measure the aperture of a dry lens unless adjusted for and measured as a dry lens. If the lens is so contrived that it can be used either wet or dry, then the aperture will necessarily be greater when used wet than dry. I possess a Dallmeyer's  $\frac{1}{4}$ th, which can, by suitable adjustment, be used either wet or dry. The angle when used wet is  $70^\circ$  measured in the cube of glass, and  $55^\circ$  when accurately adjusted and used dry.

It may give increased weight to what I have said to add that the modification of Professor Robinson's method spoken of has been submitted to Professor Stokes by Mr. J. Mayall, jun., and he admits its validity; and furthermore, Mr. Mayall has employed it in my presence for measuring the aperture of various immersion lenses; amongst others, Tolles'  $\frac{1}{4}$ th, belonging to Mr. Crisp, and the measurements so made confirm Mr. Tolles', that is, the aperture of the lens in question was found to be nearly  $100^\circ$  in the cube of glass. It is but right I should state that the aperture of the same lens was measured by Mr. Wenham in my presence, by his semi-cylinder and turn-table method, and with a metal stop of  $\frac{1}{10}$  of an inch in diameter fixed in the focal plane, and the measurement very nearly approached  $100^\circ$ .

I shall not enter upon the question of the utility of slits or metal stops for measuring immersion apertures, as I believe Professor Keith's criticism in the Journal for December last\* effectually disposes of this part of the subject. I will, however, direct attention to the fact that Mr. Ingpen appears to think the slit is properly used when "separated to the exact diameter of any field of view, thus excluding all but 'image-forming rays.'" Those microscopists who have followed Mr. Wenham's more recent statements as to the right use of the slit will at once perceive that whilst he insists the slit should admit only the merest line of light, Mr. Ingpen thinks it should not encroach on the field of view. It is to be presumed that Mr. Ingpen has given the subject due consideration, and I hope he will at some future time favour the

\* Page 284.

readers of the Journal with a more detailed exposition of his reasons for considering the slit "a valuable adjunct," while the method in which he would employ it is so entirely at variance with Mr. Wenham's. I am perfectly aware that when Mr. Wenham first brought forward his slit method he wrote, "it is preferable to open the slit till the edges appear in the margin of the field;"\* but in a later paper vindicating his report on the aperture of Tolles'  $\frac{1}{4}$ th, he appears to have abandoned this specific direction as to the size of the slit, and he now relies on some infinitesimally narrow slit, which he says should "cut off all lateral pencils"; however, with Professor Robinson's modified method no slit is required, and most conclusive and reliable results will be obtained.

\* 'M. M. J.,' vol. xi, 1874, p. 118.

---

## PROGRESS OF MICROSCOPICAL SCIENCE.

[www.libtool.com.cn](http://www.libtool.com.cn)

*The Potato Disease.*—Mr. Berkeley, writing to the ‘Gardeners’ Chronicle,’ says:—Since the meeting of the Linnean Society, of which a report was given in the ‘Gardeners’ Chronicle, March 25, 1876, Mr. Smith has forwarded to me several slides containing specimens of the organisms he found at Chiswick in 1875. Having examined them very carefully, I think it but justice to state what I have observed. 1. The oogonia seated on thick, often flexuous threads, with a septum beneath the oogonium which is sometimes carried far down the thread. 2. Many instances in which the oogonium is produced in the middle of the thread, with a septum at either end, calling to mind the figure of Montagne’s Artotrogus. In several instances a process terminated the oogonia, as if the thread was to be produced so as to leave the oogonium in the centre. 3. In one oogonium I found an echinulate body, quite as strongly echinulate as in the best specimens of Artotrogus. 4. The so-called antheridia produced on delicate threads, quite distinct from those of the oogonia, and not separated by a septum. The form of the antheridia is exactly what Smith has figured. 5. The antheridia in contact with the oogonia, in one instance the wall of the oogonium being perforated, as if by the act of impregnation. I cannot, however, speak more positively on this point. 6. Abundant Peronospora; threads and spores mixed with the oogonia and antheridia. Of course Mr. Smith’s interpretation of what he has seen is subject to criticism, but his good faith is so far confirmed by his specimens that criticism should be very guarded and gentle. If I may express my own opinion, I believe that all these objects belong to one category, and if so, I should be ready to receive De Bary’s Phytophthora (plant pestilence) as a good genus, differing in several respects from Peronospora.—From the ‘Gardeners’ Chronicle,’ p. 436, 1876.

*The Secreting Organs of the Alimentary Canal in Insects.*—In *Blatta orientalis*, the common cockroach, M. Jousset has recently been following out the course of the digestive system,\* and the following are the principal results at which he has arrived. The secretion of the salivary glands, and this alone, is able to convert starchy matters into glucose. The gastric cæca secrete a yellowish liquid, feebly but distinctly acid, which dissolves coagulated albumen, casein, and fibrin. The albuminoids are not merely dissolved, but actually converted into peptones. In addition to this solvent property, the liquid in question is capable of emulsifying fatty matters. It seems, in short, to combine the properties of the gastric juice of the higher vertebrates with those of the pancreatic fluid. The intestinal portion of the tube does not appear to take any part in the digestive function; the peptones, oily matters, and sugar, undergoing absorption before the food

\* See ‘Comptes Rendus,’ Jan. 3; and ‘Acad.,’ Feb. 12.

leaves the stomach. The secretion of the Malpighian tubes exerts no action on the albuminoid, starchy, or fatty matters. It contains uric acid and urates, and is, in all likelihood, wholly excrementitious.

*A New Classification of Cryptogams* has been proposed by Professor J. Sachs, and is partly given in the botanical notes of the 'American Naturalist' (March).—Professor Sachs proposes a new classification of the lowest section of cryptogams, which he distinguishes as *Thallophytes*, including the classes, hitherto considered distinct, of *Algæ*, *Fungi*, *Lichens*, and *Characæ*. He divides the section into four classes, each consisting of two parallel series, the one containing chlorophyll and commonly known as *Algæ* (including *Characæ*); the other destitute of chlorophyll and commonly known as *Fungi* (including *Lichens*). The classes are as follows:—**Class 1. PROTOPHYTA.** This class comprises the simplest known forms of vegetable life, unicellular, or the cells connected into filaments, rarely into more complicated tissues; no mode of sexual reproduction is known. To the chlorophyll-containing series belong the *Chroococcaceæ*, *Nostocaceæ*, *Oscillatoriaceæ*, *Rivulariaceæ*, *Scytonemacæ*, and the *Palmellaceæ* (in part); to that destitute of chlorophyll the *Schizomycetes* (bacteria) and *Saccharomyces* (yeast). **Class 2. ZYGOSPOREÆ.** Asexual propagation various; sexual propagation by means of zygospores, the result of a process of conjugation. This is divided into two sections. In the first the conjugating cells are locomotive, as in the *Volvocineæ* and *Hydrodictyces* (containing chlorophyll), and the *Myxomycetes* (destitute of chlorophyll); the second section includes the forms in which the conjugating cells are stationary, namely, in the first series the *Conjugatæ* (comprising the *Mesocarpeæ*, *Zygnemacæ*, *Desmidiææ*, and *Diatomaceæ*); in the second series the *Zygomycetes* (comprising the *Mucorini* and *Piptocephalidæ*). **Class 3. OOSPOREÆ.** Reproduction by oogonia, containing an oospore or embryonic cell, becoming an oospore or resting spore by the act of impregnation. In the series containing chlorophyll are *Sphaeropleæ*, *Vaucheyia*, the *Edogoniææ*, and *Fucaceæ*; in the series destitute of chlorophyll the *Saprolegniææ* and *Peronosporææ*. **Class 4. CARPOSPOREÆ.** A distinct organ, or "sporocarp," results from the process of the fertilization of the female organ, or *carpogonium*. In the first series are the *Coleochaetææ*, *Floridææ*, and *Characææ*; in the second, the *Ascomycetes* (including *Lichens*), *Æcidiumycetes*, and *Basidiumycetes*. This classification of the lower cryptogams appears to be founded on sounder principles and a more thorough knowledge of their structure, and especially their mode of reproduction, than any hitherto proposed.

*Characters of the Slime of Phosphorescent Fish.*—It is stated by E. F. Pflüger,\* after giving some observations on the relative phosphorescence of fresh-water and salt-water fish, that the microscopic structure of the slime covering the bodies of phosphorescent fish was then investigated. It was found to consist of lower organisms, the so-called schizomycetes, which are the proper luminous materials.

\* Pflüger's 'Archiv,' xi.

This was shown by a filtration experiment, where the organisms were retained upon the filter (fine thick non-sized printing paper; Swedish filtering paper does not do) which remained luminous, while the perfectly clear filtrate was absolutely non-luminous, this clearly showing that the **small living cells** of the schizomycetes are the cause of the luminosity; and further, the author's experiments furnish strong proofs that the schizomycetes do not arise "spontaneously," but from spores.

*On the Development of Spindle-cells in Nested Sarcomas.*—Dr. Gowers read an able and interesting paper on this subject before the Pathological Society, which has been thus reported by the 'Lancet' of April 22:—The tumours thus designated consisted of spindle-cells with a few round cells, and had, further, this peculiarity, viz. that the spindle-cells were in part arranged concentrically in nests, resembling very closely the nests of epithelioma. The microscopical characters of the cellular elements were fully detailed. The nuclei of the cells were larger in proportion to the size of the cell in the softer and more rapidly growing parts of the tumour, while in the denser portions the cells were finer and more like fibres. In some parts, round cells were observed in process of development into the spindle-shaped varieties. The "cell-nests" varied from  $\frac{1}{100}$  of an inch to  $\frac{1}{200}$  of an inch in diameter, and were distinctly seen to be composed of concentric layers of fusiform cells, the outermost layers being in many specimens partly detached. These observations were founded upon three examples of the tumour which sprang from the inner surface of the cranial dura mater: they were globular and nodulated, and had displaced the brain-substance in their vicinity. They varied in consistency, but the older portions of the growths were firmer than the more recent parts, and in one specimen the whole tumour was soft throughout. In colour the growths were of a reddish grey, the softer parts resembling in tint and consistency grey cerebral substance. In these tumours the origin of their constituent spindle-cells could be readily traced; the process being found to consist in an endogenous development from round cells, the process described as vacuolation by Dr. Creighton. The following is a brief outline of the changes as observed in different stages of progress in different parts of the growth. The nucleus of the small delicate-walled round or oval cell, which is at first in or near the middle of the cell, becomes excentric in situation, whilst a clear space occurs in that part of the cell which is away from the nucleus; and as the cell increases in size its granular protoplasmic contents become more and more confined to the periphery, till at length the "crescentic" or "signet-ring" form of cell is produced. The nucleus now lies imbedded in the protoplasm where this is thickest. Gradually the inner margin of the crescent-shaped body becomes more defined, until at length there is produced a spindle-cell, which gradually separates from the central mass of the original cell-body. Many were seen in process of separation, and in those recently detached their crescentic shape denoted the manner in which they had arisen. When the original nucleus remains single

the spherical cell only gives rise to a single fusiform cell; and if the nucleus divides after it has acquired its lateral position, the resulting spindle-cell contains two nuclei. But occasionally the division of the nucleus takes place before or soon after the process of vacuolation commences, and in this case one nucleus remains behind within the hyaline area, and is often surrounded by some granular protoplasm. It may here be developed into another cell, thus lying within the first spindle-cell. The repetition of this process by repeated multiplication of the nuclei produced the concentric nests. This process of vacuolation can only be distinctly seen in the rapidly growing portions of the tumour, and it was only distinct in fresh specimens. The exact nature of the process and of the hyaline contents of the vacuoli is uncertain. It would appear that these contents are composed of some new, delicate material, at first protoplasmic. The process may be regarded as a simple movement of the nucleus and granular protoplasm to the periphery of the cell, but the sharp outline of the vacuoli and the tenuity of the periphery suggest that there is an active distending force concerned in the process. Vacuolation in most cases terminates the active life of the original cell; and division of the nucleus only leads to multiplication of the cell if it precede or accompany, not if it succeed, the vacuolation process. The paper concluded with a reference to various descriptions and drawings of the process by different writers, who have, however, for the most part misinterpreted its nature. The examples show how various is the part played by the process in tissue changes. The paper was illustrated by a series of well-executed drawings.

Mr. Knowsley Thornton had recently examined carefully some specimens of peritoneal cancer, and had found numerous vacuolated cells surrounded by rings of protoplasm. He had never seen anything like an intrusion of other cells into the vacuoli; and concurred with the view maintained by Dr. Gowers as to the endogenous formation of the new cells. In some specimens a round cell presented central vacuolation, an excentric nucleus surrounded by granular protoplasm, within which a development of small cells appeared to be taking place. Staining reagents brought clearly into view the darker granular mass bounding the cell, and this mass seemed to be undergoing a process of cleavage. He had not been able to trace, as Dr. Thin had, the cells to their original starting place; but in the peritoneum he had noticed projections of oval or round masses of granular material from the stomata, surrounded by germinating endothelium. He could not satisfy himself as to the origin of this material.

Dr. Thin agreed with Dr. Gowers that the process of vacuolation was not a new discovery. He had, however, never heard it so explicitly stated as on the present occasion. Had Dr. Gowers disintegrated any of the large "nested cells," and did he believe that division of the nucleus was essential to the formation of the second cell? With regard to Mr. Thornton's remarks, he was surprised that the ideas of stomata and lymph-calicular systems should be so generally adopted. Many able histologists, including Ranvier, had denied the existence of

these stomata. Nor did he (the speaker) believe in the germination of epithelium. With regard to endogenous cell-formation, all its appearances were explained by the entrance into the cells of leucocytes, a process which he was convinced did occur. He had devoted much time and labour to enable him to recognize lymph-corpuscles, and he thought he could recognize in the drawings accompanying Dr. Gowers's paper evidence in support of his view.

Mr. Hulke said that he would receive with very much hesitation the statement that leucocytes have such a remarkable tendency for wandering into the tissues and into other cells. In a leucorrhœal discharge one found numerous large definite squamous cells, containing not one, but two, three, or four definite rounded bodies, which certainly were not leucocytes. He instanced also the case of suppuration of the vitreous humour, enclosed in its definite hyaloid membrane, and separated from the choroidal capillaries by the membrana limitans and the whole thickness of the retina and the pigmentary epithelium and elastic lamina of the choroid, and thought that the travelling powers required by the leucocytes to penetrate all these structures were more than could be granted. On the other hand, the vitreous possesses traces of foetal structure, vestiges of embryonic cell-tissue, which can be seen distinctly to be enlarged and replaced by bodies indistinguishable from pus-cells. He was then very sceptical about the enormous powers which were attributed to the white blood-cells.

Dr. Gowers, in reply, remarked that Mr. Knowsley Thornton's observations on the multiplication of nuclei in the peripheral zone of vacuolated cells were interesting. He had not observed such multiplication after vacuolation, and asked whether they might not have been formed before vacuolation, and pushed to the periphery by the process. In reply to Dr. Thin, the character of the outer cells of the nests could be seen readily, since one or two were often half detached; they were simple spindle-cells curved according to the shape of the globe. He could not accept Dr. Thin's view that the second nucleus within a vacuolated cell was a leucocyte which had wandered in. The nucleus resembled closely the original nucleus of the cell. If a nucleus were seen in a certain position, he thought that the first inference suggested was that it had been formed there, not that it had wandered in. This inference was strongly supported by observation of the nests of cells, since there was a simultaneous increase in the number of nuclei in the centre and of spindle-cells in the outer part of the nest. But the more numerous the circumferential cells, the greater the obstruction to the entrance of cells from without; and it was therefore probable that simultaneous increase in the nuclei within was due to their formation at the spot, and not to their migration from without.

*Measurement of Nobeit's Bands.*—A very valuable paper on this subject was some time since laid before the Royal Society, and we had hoped to have had an opportunity of reproducing it in full in these pages. As the opportunity has not offered, we think it better to give a portion of the essay, that relating to Nobeit's bands, and to give the general conclusions at which the author arrives. The paper



in question will be found in the 'Proceedings of the Royal Society,' No. 163, and it is by Mr. J. A. Brown, F.R.S.

The following table contains the results of the observations of Nobert's test-lines.

www.libtool.com.cn

MEASURES OF NOBERT'S TEST-LINES.

Band.	Number of Lines.	Width of			Number to the Inch.			Ratio.
		Line.	Space.	Band.	Lines.	Spaces.	Both.	
I.	7	28.57	58.67	553	35,000	17,040	11,460	1.00
II.	10	35.10	23.00	560	28,500	43,450	17,210	1.68
III.	13	27.85	14.85	555	35,910	67,340	23,420	2.11
IV.	15	19.13	15.57	505	52,270	64,230	28,820	3.10
V.	17	14.10	15.20	480	71,430	65,790	34,250	3.87
VI.	20	11.55	13.90	495	86,580	71,940	39,290	4.23
VII.	23	12.64	9.14	505	79,110	109,410	45,910	4.65
VIII.	25	8.71	10.71	475	114,810	93,370	51,390	5.49
IX.	28	7.47	9.93	478	133,870	100,700	57,470	5.92
X.	30	8.11	7.44	460	123,300	134,410	64,310	7.25
XI.	34	8.10	6.90	500	123,300	144,930	66,670	7.25
XII.	37	6.81	7.28	503	146,840	137,360	70,970	8.08
XIII.	40	6.62	6.00	500	151,060	166,670	79,240	8.89
XIV.	43	6.00	6.00	510	166,670	166,670	83,330	9.81
XV.	45	5.56	5.56	495	179,860	179,860	89,930	10.50
XVI.	(40)	..	..	522	..	..	77,280	
XVII.	(40)	..	..	{503 512}	..	..	77,880	
XVIII.	(40)	..	..	{489 511}	..	..	79,240	
XIX.	(40)	..	..	540	..	..	75,760?	

*Notes.*—These measures are frequently mere approximations; and in several bands the graving-point has made a wonderful approach to an equality of width of lines and spaces; indeed, these lines are marvels of mechanical skill. If, in the case of each band, the first and last lines had been drawn longer than the rest, it would have been possible to measure the width of a line with considerable accuracy, since, as has been shown, the visibility of a single line is nearly twenty times that for the series.

The widths of the lines and spaces are those taken from the photographs, the unit being  $\frac{1}{1000}$  inch. The photographs are magnified to 1000 times. In bands XVII. and XVIII. second measures are given from photographs magnifying to 1600 times (but reduced to the same unit). The number of lines in ( ) are the numbers counted for which the total width was measured. The number for the XIXth is deduced from the measure of a few where the lines were most distinct. The numbers of lines and spaces to an inch are the numbers which could be put in an inch laid side by side (without interval). Under "Both" is given the number of lines to the inch (with interspaces), as in the bands. The "Ratio" is that of the number for the widest space (17,000 to the inch) to the number for the widest line or space in the following bands.

It will be seen that the least width of the lines which can be counted and measured on the photographs is about  $\frac{1}{180000}$  of an inch (XIIIth band). We have seen (5th observation) that dark parallel lines on glass can be seen with transmitted light when their width subtends an angle of 20" to 26"; so that lines stopping the light moderately (7th observation) of  $\frac{1}{180000}$  of an inch wide should be

seen with a power of 125, and counted with a power of 160 (the distance for the unaided eye being considered 8 inches). We have, however, obviously in the high bands to include the case of observation 7, the lines on the photographs being excessively faint. When we add to this fact (a most important one when such lines are supposed to give some measure of the power of the microscope) that it appears that separate lines cannot be drawn of a less width than about  $\frac{1}{180000}$  of an inch under the diminished pressure of Mr. Nobert's machine without the graving-point sliding into previous grooves, we have a sufficient explanation why the power of the microscope cannot be measured by these lines.

The following are the conclusions of this note :

1st. That lines can be seen by the naked eye with transmitted light the width of which subtends an angle of about  $1''$ .

2nd. That the visibility of a line, or the distance at which it can be seen, depends on the logarithm of its length, the product of the angle subtended by the width and the cube root of that subtended by the length being nearly constant.

3rd. Short parallel lines could be seen by transmitted light when the angle formed by the width of the spaces and intervals was  $20''$ .

4th. The visibility of lines of the same width increases as the distance between them decreases.

5th. The visibility of parallel lines depends on the darkness of the shade or tint of the lines up to a certain feeble tint, after which no blacking of the lines increases the visibility; the distance to which the lines can be seen depends on  $c^t$ , where  $c$  is a constant and  $t$  is the number of the tint or shade (the number of coats of a weak tint).

6th. The visibility of dark parallel lines lighted with a candle depends on the logarithm of the distance of the candle from the lines; and they can be seen as well with a candle placed quite near as with the strongest daylight. This results from Tobias Mayer's observations.

7th. The visibility of parallel lines depends on the logarithm of their length, as in the case of single lines, the variation being much greater for short parallel lines than for long ones. Also for short parallel lines the product  $a^2/\beta$  is nearly constant, as for single lines.

8th. Parallel lines are least visible when there are only two, and increase in visibility with their number.

9th. Nobert's test-lines fail as a test for the microscope, especially in the highest bands, from the incapacity of the machine to make separate lines at less intervals and of less width than  $\frac{1}{180000}$  of an inch; they also fail, in all probability, on account of the faintness of the tint or shade of the lines made on the retina.

*A peculiar Process of Development in certain Fungi* has been recently recorded before the French Academy, and has been well abstracted by the 'Academy,' which says that M. Ph. van Tieghem has made fresh observations on the development of agarics of the genus *Coprinus*, and on the supposed sexuality of *Basidiomyces*, which differ from the conclusions lately arrived at. He finds that certain rods (*batonnets*) which appeared to be male organs, and to act as fecun-

dators, are capable of independent germination. "These organs," he says, "are therefore not male fecundating corpuscles (spermata or pollinides), but a particular kind of spore, usually alterable and ephemeral." He also states that he has seen the fruits of *C. plicatilis*, *radiatus*, and *filiformis* develop and ripen in a cell, or a mycelium, under conditions in which no rods were produced or introduced. The incapacity to germinate, alleged on the part of the rods, was, M. van Tieghem says, only a negative argument, which falls before the fact of their germination, which has been ascertained. If some of the rods are placed in a drop of manure water they are seen in a few hours to become oval, and even spherical, after which they push forth vigorous mycelium tubes, which branch and anastomose. Two days later, the mycelium produces more groups of *baguettes*, which disjoint themselves into the rods. This is their normal generation. If, however, they are sown in great numbers, so that they are close together in the nutritive fluid, the conidia do not enlarge sensibly, but emit very narrow tubes perpendicular to their axes, which anastomose like the letter H. If the rods are transferred to a drop of fluid, in which a mycelium of the same species is already developed, they behave in an analogous manner, and anastomose with the mycelium. If at the point of union the mycelium branch is somewhat exhausted, they pour their protoplasm into it, and renew its activity. After supplying further details, M. van Tieghem says: "The various copulations of the rods we now know are vegetative phenomena, beginnings of germinations under conditions in which normal germination cannot be accomplished, and with manifestations of the general property of anastomosing and grafting, which all the cells of these plants possess in a high degree. . . . The theory of the sexuality of the basidiomycetes, apparently based upon the most demonstrative of processes, cannot resist a more profound study. Will it be so with the basiomycetes? This will be treated in another paper."

*Emigration of Blood-corpuscles.*—Herr J. Arnold has been investigating this subject, especially with regard to the conditions of the walls of the blood-vessels during the passage of the corpuscles. He states\* that he injected a weak solution of silver into the blood-vessels of frogs, in which single parts of the body had been inflamed twenty-four hours previously. The appearances of the so-called endothelial figures varied considerably from the normal. The "cement lines" appeared as broad, strong, zigzag lines, or were only indicated by rows of granules. There are large dark points in them, the stigmata; and in the cement substance as well as in the stigmata are to be found white corpuscles in the act of passing out of the vessels, and this in various stages of their passage. Not unfrequently several colourless corpuscles are to be seen attached to one part of the cement substance, or to one of the stigmata; thus, two corpuscles may be lying within the vessel, and fixed by short processes in a stigma, whilst a third one for the most part has penetrated and only remains in connection with the vessel by means of a short process. Sometimes the accumulation of the white corpuscles on the outer side of the vessel, in the neighbourhood

\* Virchow's 'Archiv,' Bd. lxii., p. 47; and 'Med. Record,' Feb. 15.

of the stigmata, is so considerable, that the sheath of the vessel, at the corresponding spot, stands out like a little hump from the epithelial layer. From this the author concludes that the white blood-corpuscles in inflammation pass through the wall at the cement substance, i. e. the stigmata; whilst, on the contrary, he never saw that other parts of the wall of the vessel, e. g. the epithelium, was permeable to the white blood-corpuscles. From experiments made with gelatine and fine vermilion injections, it seems that, in addition to the pronounced wandering out of colourless blood-corpuscles connected with disturbances in the circulation, other corpuscles also pass through the wall of the vessel; and apparently this also happens at the portion of the stigmata and cement substance. When blue-coloured gelatine instead of the vermilion was employed, the inflamed vessels at numerous spots here seemed to be covered with small roundish blue protuberances, or with more elongated blue processes. From this it results that the wall of the vessel permits not only substances in solution to pass through it at the position of the stigmata and cement substance, but also a colloid body (gelatine) and other elements (vermilion). The masses which have passed through the vascular walls, penetrate in the direction of the "juice canals" ("*Saftcanalsystem*") in the tissue, and under certain circumstances these can be completely filled laterally with the injection mass. Still the configuration of this system of spaces when injected is variable, according to the disturbances of the circulation which have occurred in the tissues. Whilst the juice-canals during venous stasis possess a broad and ampullated form, they appear smaller, and more zigzag in those disturbances of the circulation which are specially characterized by the exit of white blood-corpuscles.

---

## NOTES AND MEMORANDA.

---

**A New Form of the Phylloxera.**—M. Balbiani, the distinguished entomologist, has addressed to M. Dumas a letter on the egg of the phylloxera, from which the following passages are gleaned as being of importance:—"I have to inform you that on examining, this morning, April 9, through the magnifying glass, a certain quantity of winter eggs I had collected a few days ago (there were some twenty of them on the same bit of vine shoot, 19 centimeters long), my attention was suddenly attracted to a yellow point there was among these eggs. It turned out to be a young phylloxera just hatched, for the little parasite still carried the egg-shell about with him. For more than two hours it remained perfectly motionless, but all its appendages, feet and antennæ, were entirely spread out and well visible. At length it began to move, and soon grew rather lively on the lamella of bark on which it stood. By microscopic inspection I acquired the conviction that the offspring of yesterday's egg, which, according to all analogy, represents the fundamental progenitor of the subterranean colonies, really constitutes a fourth

specific form of the vine phylloxera; for it has characteristics that distinguish it from all other shapes hitherto known. . . . Its size is  $\frac{1}{100}$  of a millimeter in length by 16 in breadth. It has long and slender antennæ, a fusiform terminal article attenuated at its base and a well-developed rostrum, the point of which advances down to the middle of the abdomen. . . . The individual I have been describing is the only one of its generation I have yet obtained; I cannot therefore give any information as to its habits; but among the eggs that were on the same vine shoot there are several containing a well-developed embryo, which is recognizable by its two red ocular points, visible through the teguments of the egg. I hope, therefore, to be able to make some further observations."

**Microscopy at the American Association.**— This, which has hitherto been feebly developed, bids fair to become a prominent part of the Association in future years. This Section, which was formed at the last meeting, is now undergoing favourable development. The club which has been started for the purpose, now invites all persons interested in the microscope, and desirous of joining such an organization as is now proposed, to be present and co-operate, whether at present members of the Association or not, and they are requested to bring to the meeting original papers of scientific interest upon subjects connected with the microscope and its work, and also to bring instruments, accessories, and objects, especially those illustrating new or unfamiliar inventions, contrivances, and discoveries. It is hoped that the participation of microscopists in this movement will be prompt and cordial.

---

## CORRESPONDENCE.

---

*To the Editor of the 'Monthly Microscopical Journal.'*

HOBART COLLEGE, GENEVA, N.Y., April 10, 1876.

Sir,—Mr. Hickie in his reply to Dr. Woodward, in the March number of the 'Monthly Microscopical Journal,' makes two distinct issues: First, *Frustulia Saxonica* has true longitudinal lines; and second, *Frustulia Saxonica* is not *Navicula crassinervis*. I do not intend to discuss the first; Dr. Woodward and Mr. Hickie must settle that for themselves; but the second statement is, in my opinion, erroneous; and I am sure Mr. Hickie, when he has made more complete study of the Diatomaceæ, especially as to what is to be considered of value in establishing species and genera, will agree with me. Let him read Mr. Kitton's article on "the publication of new Genera and Species from insufficient material."\*

Mr. Hickie sums up the evidence in favour of his assertion

\* 'Journal Quekett Microscopical Club,' Feb. 1867, and published in 'Q. M. J.,' vol. vii., N. S.

that *Frustulia Saxonica* and *Navicula crassinervis* are not the same diatom, as follows.\* "Dr. Rabenhorst discovered a certain diatom in Saxon Switzerland and named it *Frustulia Saxonica*. De Brebisson also, as I understand, discovered a certain diatom and named it *Navicula crassinervis*, and did so under the impression that what he so named was something totally different from what Dr. Rabenhorst had called *Frustulia Saxonica*. Dr. Rabenhorst, again, in the letter I read to you, says expressly, that he who identifies these two diatoms, must be ignorant of one or other of them

"Now, if there be any two greater Continental authorities than Dr. Rabenhorst and the late De Brebisson, I should like to know who they are."

So far good. I accept the position. Let us see what these two great Continental authorities really do say—not by letter, now when they have forgotten what they have really said before (which indeed is not remarkable for Dr. Rabenhorst, who is a most industrious compiler), but what they published, when the subject was under fresh investigation. First, Dr. Rabenhorst. In his latest publication on the Diatomaceæ, as a whole, 'Flora Europæa Algarum, Sectio I, Algas Diatomaceas Complectans,' p. 227, he says, "*Frustulia Saxonica*, var. c, forma aquatica (*Navicula crassinervis* Bréb. 1852! in Sm. Diat. p. 47, tab. xxxi. f. 271)." Observe, this has the botanical mark of identification! and, curiously enough, he says, "*striis oboletis, longitudinalibus distinctioribus*." How about the ignorance of the Doctor himself? But now, second; the other "great Continental authority," and justly so called. In a paper published in 'Annales de la Société Phytologique et Micrographique de Belgique,' 1868, upon *Vanheurckia*, a new genus of the Diatomaceæ, Brébisson says, "*V. crassinervis* Bréb.—*Nav. crassinervis* Bréb. MSS. W. Smith, Brit. Diat. i. p. 47, pl. xxxi. f. 271—*Frustulia torfacea* Braun, et *Nav. Saxonica* (*Frustulia*) Raben. Diat. 50, t. 7." How about De Brebisson's ignorance?

Here, then, each of Mr. Hickie's authorities states that *N. crassinervis* and *Frustulia Saxonica* are the same; moreover, in Rabenhorst's Algen, as stated by Grunow, *Navicula crassinervis* Bréb. occurs in his No. 48, as *Frustulia Saxonica*, and Grunow himself, quite as good an authority, to say the very least, as Dr. Rabenhorst, states explicitly, in "Ueber neue oder ungenügend gekannte Algen," 'Verhandl. der K. k. Zool. Bot. Ges.' x. B. 1860, p. 573, "*Frustulia Saxonica* Rabenhorst, ist *Navicula crassinervis* Bréb.," &c. Mr. Ralfs, who does not seem to have examined any authentic specimens of *N. crassinervis*, but gives Rabenhorst's description, remarks, in Pritchd. Infs. p. 924, "*F. Saxonica* (Rab.) slenderer than *F. torfacea*," but the latter, he says, "from an authentic specimen appears to be identical with *Navicula rhomboidea*." I have already noted that De Brébisson considers *F. torfacea* and *F. Saxonica* the same. Again, W. Smith, in the British Diatomaceæ, vol. ii. p. 69, suggests that *Nav. crassinervis* (this was the original name, it should be "*crassinervis*") is the free state of *Colletonema vulgare*, and in this he was undoubtedly right; and Donkin,

\* See 'M. M. J.,' March 1876, p. 127.



in Brit. Diat. pt. ii. pl. v. f. 3, has figured a small specimen of this as *Nav. dirhynchus* E. Again, N. G. W. Lagerstedt, in his 'Fresh-water Diatomaceæ from Spitzbergen and Behring Island,' gives the following list of synonyms, p. 32: "*N. Saxonica* Rabenh.—*Frustulia Saxonica* Rabenh. Bac. Sachs, No. 42 (1851) (see Rabenh. FL Eur. Alg. Diat.). Grun. in Rabenh. Beitr. H. ii. p. 10, t. i. f. 13. *N. crassinervis* Bréb. in Wm. Sm. Syn. Brit. Diat. v. i. p. 47, p. xxxi. f. 271. Grun. in Wien Verh. 1860, p. 548, t. 3, f. 12."

But once more. Mr. Hickie has expressed a very high opinion of Schumann's 'Diatomeen der hohen Tatra.' In this remarkable work, p. 79, I find "*Frustulia Saxonica* Rabenh. . . . Sie tritt in folgenden Formen auf. 1. *Nav. crassinervis* Bréb. Syn. (Brit. Diat.) s. 47, xxxi. 271." Dr. Pfitzer, in his 'Untersuchen über Bau und Entwicklung der Bacillariaceen,' Bonn, 1871, p. 61, enumerates the particulars in which *Colletonema vulgare* and *Frustulia Saxonica* agree, so that if W. Smith, Brit. Diat. vol. ii. p. 69, is right, we have here another evidence of identity between *Navicula crassinervis* and *Frustulia Saxonica*. Suppose now we tabulate results, naming only authorities.

*In favour of the identity.*

Rabenhorst, in 1864.  
De Brébisson.  
A. Grunow.  
Ralfs, by inference.  
W. Smith, ditto.  
Lagerstedt.  
Schumann.  
Pfitzer, by inference.

*Against it.*

Rabenhorst, 1875.

It is true that Mr. Hickie quotes Mr. Morehouse; but with all credit to the skill of this gentleman in resolving test-objects, I do not think he claims to be an "authority," and I presume knows the diatoms in question only as named by Möller, and other dealers.

Finally, the genus *Frustulia* should be abolished; and I am quite sure that Mr. Kitton, who is, I suppose, at the present time, one of the best, if not the best of English authorities, will agree with me. It was constituted to receive species of Diatomaceæ imbedded in amorphous gelatinous substance. I have repeatedly observed *Colletonema vulgare*, which in running water is found in tubes, when transferred to quiet water, and exposed to good light, to lose all traces of tubular structure, developing only an amorphous gelatinous mass; and the little *Navicula atomus* = *Frustulia pelliculosa* is very remarkable in this respect. Mr. Hickie is right in uniting *Frustulia* (*Nav.*) *Saxonica* with *Navicula rhomboides*. The latter often occurs in tubes, and De Brébisson's *Frustulia* (*Vanheurckia*) *viridula* is identical with *Navicula rhomboides*, and also with his *Nav. crassinervis*. I have specimens of all these direct from him, and the difference is too slight to warrant, with our present views as to what is sufficient for such a purpose, the establishment of new species; they merge into each other by almost imperceptible gradation. Everyone who has studied the Diatomaceæ, except as curiosities, or as test-objects, nay, even in this latter case, is aware



of the great variation in outline and striation in the same species, and this, not only when contrasting sporangial forms, and their immediate successors with the parent frustules, but as dependent upon surroundings. Disregarding, then, their fleeting characteristics, and looking at the subject from a somewhat higher plane, and with broader views, simplifying rather than confusing the study of these interesting organisms, I cannot but consider them all as varieties of Ehrenberg's *Navicula rhomboides*.

Most of the group to which the so-called *Frustulias* belong still retain an investing sheath or cuticle, enveloping the frustule when it is separated from the gelatinous mass, or the tubes, and which becomes dark brown upon burning, and often wrinkled. If the burning is insufficient, the colour still remains: as most of the dry preparations are now made by incineration, this may account for the colour noticed by Mr. Hickie. In the closely allied *Amphipleureæ*, the wrinkled sheath gives an appearance of resolvability to some frustules even with very low powers; and I have often noticed this with *Collettonema vulgare*.

H. L. SMITH.

[Professor H. L. Smith having requested me to revise the proof of the above letter, I take the opportunity of stating that I fully agree with him that the genus *Frustulia* should be abolished; and I am also of opinion that *Navicula crassinervis* is only a form of *N. rhomboides*. I may also state that my friend Mr. Hickie is of the same opinion.—F. KITTON.]

MR. TOLLES'  $\frac{1}{8}$ TH AGAIN! \*

To the Editor of the 'Monthly Microscopical Journal.'

BOSTON, May 2, 1876.

SIR,—We have the authority of Mr. Wenham, found on p. 225 of 'M. M. J.' for May last, that a certain  $\frac{1}{8}$ th objective *did* work through a plate of glass .018" thick, and this is given as the thickest it would penetrate and come to the focus on the under surface thereof. This distance in glass he has repeatedly said is practically the same as in balsam.

\* Mr. Tolles has sent us besides the above, another communication on the same subject, which, however, we decline inserting. We must positively refuse publication to any other letters relating to Mr. Tolles' particular apertures, which we are sure our readers are heartily weary of.

By comparing the figures on the above diagrams with the dimensions given by Mr. Wenham on page 153 of this Journal for March, and at page 184 for April, it will be seen that Mr. Tolles in both of them, in order to make out his case, has taken different dimensions of working diameter and focal distance from those of Mr. Wenham. This is mere contradiction, and no argument.

Mr. Wenham in his article in this Journal for April last, page 185, now stands responsible for the statement that "all measurements for ascertaining large apertures have hitherto been erroneous, and far in excess of the true pencil." As this is of importance, we shall be glad to afford space in our pages for a proper discussion as a pure question of science. If it is taken up as a personal one, letters having this tendency will not appear in our pages.

The diagram, Fig. 1, is his own (except the dotted lines), showing  $118^\circ$  to be the utmost possible for the lens, on the assumption that the whole diameter,  $\cdot 043''$ , is used, and that all the rays cross at the focal distance of  $\cdot 013''$  in air. The dotted lines added by me cross at  $\cdot 018''$  distance from the face of the lens, and show an angle of

FIG. 1.



FIG. 2.



$100^\circ$ . Were the whole exposed front surface used, this would be the balsam, i. e. *glass* angle of the objective, *provided* the cover thickness is given correctly.

Fig. 2 shows the same diameter,  $\cdot 043''$ , and the same focus through covering glass,  $= \cdot 018''$ , and a *used* diameter of  $\cdot 036''$ ; thus twice the focal distance ( $= \cdot 036''$ ) represents the used diameter giving a right-angled triangle with  $90^\circ$  at the focus.

His own later "utilized diameter" makes the balsam angle somewhat less, closely to  $88^\circ$ , but leaves the argument conclusive against his assertions of small angle in the objective.

By my own measurement the working distance of the objective through glass cover is less than  $\cdot 018''$ , and accordingly the balsam angle I claimed and claim is more than his data afford, but either exceed the equivalent ( $82^\circ$ ) of  $180^\circ$  in air.

Yours respectfully,

R. B. TOLLES.

---

## PROCEEDINGS OF SOCIETIES.

---

### ROYAL MICROSCOPICAL SOCIETY.

KING'S COLLEGE, May 3, 1876.

H. C. Sorby, Esq., F.R.S., President, in the chair.

The minutes of the preceding meeting were read and confirmed.

A list of donations to the Society was read by the Secretary, and the thanks of the meeting were voted to the donors.

Mr. Charles Brooke said he had a very pleasing duty to perform before proceeding to the business of the evening, and that was to propose that the best thanks of the Fellows of the Society be given to their President, Mr. Sorby, for the soirée which he gave to them

and to their friends on the 21st of April. He felt sure they must all have felt highly gratified at the very admirable manner in which the arrangements were conducted, and must have been extremely pleased with the interesting entertainment provided for them on that occasion.

The motion having been seconded by Mr. Fitzgerald, was put to the meeting by Mr. Brooke, and carried unanimously.

The President expressed himself as much obliged to the Fellows of the Society for the kind manner in which this vote of thanks had been proposed and carried. In making arrangements for a conversation of that kind, it happened sometimes that many things might turn up to interfere with success, and which it was not possible to foresee or to provide against, but in this case he was glad to find that everything went off as well as could be expected. For his own part, he could only now wish to thank those Fellows of the Society who assisted on the occasion by the exhibition of so many beautiful and very interesting objects.

Mr. Blake read a paper "On what appeared to be Foraminifera in the Coralline Oolite." Specimens in illustration were exhibited under several microscopes in the room. (The paper is printed at p. 262.)

The President, in proposing a vote of thanks to Mr. Blake for his paper, said that personally he felt exceedingly pleased that Mr. Blake had succeeded in finding these things in the condition in which he had described them, and there would now appear to be good evidence for deciding that they were Foraminifera, a matter which it had been extremely difficult to decide before. He called attention to a diagram suspended in the room, and which represented the results of some of his own observations upon the same subject made many years ago; and said that in a majority of cases he was unable to find any evidence that these little bodies were, or had been, shells, but in a few instances there was some indication round the margin as if it had resulted from dirt getting into the shell, and although he had found this several times, he doubted whether he could rely upon that sort of evidence alone, although his own opinion was that they had been shells. The position in which Mr. Blake had found them was also a matter of interest, as rendering it probable that they were also to be found in calcareous grit, and coralline oolite over a very wide area.

The thanks of the Society were voted to Mr. Blake for his paper.

Mr. Jas. Glaisher said that about a year since, he had the pleasure of introducing to the Society Dr. Gayer; that gentleman had then some experience in micro-photography, and he had urged him to persevere in it, and to communicate the results to the Society. This he had done, and judging by the specimens which were placed upon the table that evening, he had not done so without success.

A number of beautiful photo-micrographs were then handed round for the inspection of the Fellows, and a paper by Dr. Gayer describing the apparatus employed and the process of manipulation was read to the meeting by Mr. Glaisher. (Paper printed at p. 258.)

The President proposed a vote of thanks to Dr. Gayer for his paper, and also to Mr. Glaisher for persuading him to go on with that kind of study, and for reading the paper to them on that occasion.

The photographs were certainly very fine, and although it would be invidious to say they were the finest they had seen, remembering how many beautiful specimens they had received from Dr. Woodward, yet he was sure all would agree with him that these photographs of Dr. Gayer were very fine ones, and if he went on with that kind of work they should be very glad indeed to hear of his further success, and to see the results at some future time. He had not himself attempted photography of this kind, except with powers of 9 or 10 linear, but he knew quite enough of it to enable him to admire the very excellent work which Dr. Gayer had produced.

Mr. Glaisher said that the President had touched upon rather a delicate point in mentioning what had been done by others, and he had himself made use of this in urging Dr. Gayer to persevere; he had told him that Mr. Woodward was going so far ahead of us in this respect, that he was bound to do his utmost to produce work of the highest merit, especially as he was going to a clearer atmosphere and brighter sun than we possessed at home.

Mr. Slack said there was one feature about these photographs which appeared to him very remarkable. If they considered the extent of power to which the objects were magnified, it was surprising how very small the beads appeared, even when looked at with a magnifying glass. This he thought showed in a high degree the excellence of the work, as any defect in the objective or method exaggerated the size of such objects. These were taken with Powell and Lealand's  $\frac{1}{8}$ th. With regard to the holes mentioned by Dr. Gayer, and the existence of which was said to be confirmed by the appearance of the fractures, he could but observe that wherever a fracture was seen to have taken place, it clearly occurred between the rows of beads, and in each case the beads were seen to form projections all along the terminal portion of the fracture; so that it was only necessary to look at Dr. Gayer's own very beautiful photographs to see that what he said about the holes was not confirmed.

Mr. Charles Brooke had noticed that wherever a fracture was shown in the photographs, the row of beads on either side, and between which the fracture had taken place, was most conspicuous.

Mr. Glaisher, in reply to the President's inquiry as to the disposal of the photographs, said that he had no limit in the matter, and he should be happy to hand them over to the keeping of the Society.

The thanks of the meeting were unanimously voted to Dr. Gayer and Mr. Glaisher.

A paper by Dr. J. J. Woodward, "On the Markings of the Body-scale of the English Gnat and the American Mosquito," was read by the Secretary, and some photographs in illustration of the subject were handed round for the inspection of the Fellows. Some notes upon Dr. Woodward's remarks, by Dr. Anthony, were also read to the meeting. (See pp. 253 and 256.)

The President proposed the thanks of the Society to Dr. Woodward and Dr. Anthony for their papers, and remarked that the more they looked into these questions, the more they began to doubt the existence of some of the objects which they saw, and when they used

high powers it became a question of great difficulty how to interpret appearances. In the instance before them the drawings of Dr. Anthony really seemed to show the scale as they imagined it ought to be, but on turning to the photographs they found that these notions were not borne out. ~~Extreme caution was necessary~~ in deciding what really existed. Accurate knowledge of the laws of light and careful induction alone could enable them rightly to approach the subject.

Mr. Slack said he should like to ask how far they might rely upon these appearances? If he understood Dr. Woodward rightly, a longitudinal section of the scale would give a wavy line, and if they sent a ray of light across a number of the ridges they would certainly get diffraction lines. But such diffraction lines would not absolutely disprove the existence of beads. The questions of structure might be approached by their comparative anatomy, beginning with the easiest scales and working up towards the more difficult ones. He thought that if Dr. Woodward could make two, three, or four rows appear, by letting the light fall at different slants, there would be strong evidence in support of his idea; but when they looked at his photographs they did not find there that exact arithmetical proportion which his paper seemed to indicate.

Mr. Charles Brooke remarked that none of the photographs appeared to present anything like it.

Mr. Blake inquired if Mr. Slack could explain how the cross lines could be produced by diffraction?

Mr. Slack said that Dr. Woodward assumed that there were cross ridges, but that they were not beaded.

The Secretary said they had also received a short communication from Mr. Stodder on the subject of *Frustulia Saxonica*, *Navicula rhomboides*, and *Navicula crassinervis*. This was read to the meeting, and upon the motion of the President the thanks of the Society were voted to the writer. (See p. 265.)

Mr. Charles Stewart called the attention of the Fellows to an exceedingly remarkable little organism which was exhibited in the room by Mr. Badcock, who would be very glad to know what it was. It was an oval thing of considerable size, microscopically speaking—about as large as a small pin's head—and looked something like a gigantic *Paramæcium*, covered with cilia; and the question was whether it was a *bonâ fide* adult, or only the larval form of some creature. Possibly some of the Fellows of the Society might be able to identify it.

#### *The President's Soirée.*

On the 21st ult. H. C. Sorby, Esq., F.R.S., President of the Royal Microscopical Society, gave an admirable soirée to the Fellows of the Society and other invited guests, including a numerous gathering of ladies. The authorities of King's College kindly threw open the great hall and an extensive suite of rooms and galleries, one on the first floor being devoted by Mr. Sorby to a very liberal commissariat, arranged with the manciple. The entrance hall and staircase were decorated with fine specimens of palms and flowers; the large hall

and libraries were supplied with microscopes, and a lecture theatre occupied at intervals by Dr. Hudson, Mr. Tisley, and Messrs. How.

This soir e differed from ordinary entertainments of a similar character, by the unusual care taken to secure objects of scientific interest as well as of beauty. The President contributed a remarkably fine collection of slides of minerals, rocks, and meteorites, exhibited by Messrs. Ross, Beck, and Crouch, as mentioned in the following synopsis; also a number of micro-spectroscope objects, exhibited by Mr. Browning.

## SYNOPSIS.

## ANIMAL KINGDOM.

Benulins, &c., from the Coralline Oolite .. .. .	Blake, J. F.
Polycystins; and spines of Starfish .. .. .	Crisp, J. S.
Hunting Spider with large eyes .. .. .	Fitch, F.
Ovarian tubes of Cidaris .. .. .	Fox, C. J.
Sponge spicules; <i>Labaria hemispherica</i> .. .. .	Gray, Dr. W. J.
Forms of Arenaceous Foraminifera .. .. .	Hailes, H.
Larva of <i>Orygia antiqua</i> .. .. .	Harris, E.
Microscope and apparatus illustrating Nchet and Hayem's mode of estimating the number of red blood-globules in the blood .. .. .	Lawson, Dr.
Anatomy of <i>Octopus vulgaris</i> —Young Octopus in the egg; young Octopus just hatched; palate of Octopus; pigment cells in skin of Octopus; crystalline lens of eye of Octopus; section of arm and sucker of Octopus .. .. .	Lee, Henry.
A series of preparations of insect anatomy, including <i>Musca vomitoria</i> (Blow-fly); <i>Nepa cinerea</i> (Water Scorpion); larvæ of Lepidoptera, &c. .. .. .	Loy, W. T.
Elytron of <i>Pachyrinchus</i> , &c. .. .. .	McIntire, S. J.
Pigment in tail of Pogge .. .. .	Manners, G.
Blood of Congo Snake .. .. .	"
Vertical section of human cerebellum, injected .. .. .	Matthews, Dr. J.
Section of Ammonite, seen with polarized light .. .. .	"
Section of human muscle .. .. .	Richards, E.
Section of eye of Moth; lung of Frog, injected; drum of ear of Frog, ditto .. .. .	Roberts, J. H.
Ascidian Tadpoles; transverse section of <i>Doris gracilis</i> ; segmental organs of embryo of Torpedo .. .. .	Sanders, Alfred.
Slide of 100 Foraminifera from the Dee .. .. .	Shepherd, T.
Sections of eyes of Tiger Beetle and Moth .. .. .	Smith, J.
Renulins from the Calcareous Grit, shown along with Mr. Blake's specimens .. .. .	Sorby, H. C.
Young Echinus; eggs of insect on a feather; shells of Foraminifera; section of Echinus spine, &c. .. .. .	Stewart, Charles.
Section of sciatic nerve, stained .. .. .	Ward, F. H.
Numerous forms of Itch Mites .. .. .	West, Tuffen.
Various mounted objects .. .. .	Wheeler, Edmund.
Section of bone of Elephant .. .. .	Williams, J. R.
Section of Seychelle Cocas de Mer .. .. .	"

## VEGETABLE KINGDOM.

Crystals in plants .. .. .	Beeby, W. H.
Fruit of marine Algæ .. .. .	Carpenter, Dr. A.
Moss capsules .. .. .	George, E.
Sections of various woods .. .. .	Sigsworth, J. C.
Specimens illustrating the potato disease .. .. .	Smith, Worthington G.
<i>Pleurosigma angulatum</i> , $\frac{1}{2}$ th objective .. .. .	Swift, Mr.
<i>Batrachospermum montiforme</i> .. .. .	Vinen, P. H.
Valisneria; circulation in, with $\frac{1}{16}$ th .. .. .	Lealand, P. H.

LIVING OBJECTS.

Lacinularia and Melicerta .. .. .	Badcock, John.
<i>Volvox globator</i> .. .. .	Cocks, Mr.
<i>Conochilus volvox</i> .. .. .	Hainworth, W., jun.
Pond life .. .. .	Hembry, F. W.
Medusæ .. .. .	Ingpen, J.
Planaria .. .. .	Lewis, R. T.
<i>Conochilus volvox</i> .. .. .	Miller, Dr.
<i>Corethra plumicornis</i> larva; and <i>Lophopus crystallinus</i> .. .. .	Oxley, Mr.
<i>Lophopus crystallinus</i> .. .. .	Shepherd, T.
Fredricella .. .. .	"
Pond life .. .. .	Wight, J. F.

MINERALS, ETC.

Bolling of carbonic acid in fluid cavities of rubies and sapphires	Butler, P. J.
Fluid cavities in quartz, topaz, and tourmaline, showing the alternate passage of carbonic acid into a liquid and into a gas .. .. .	Hartley, W. N.
Organic remains in a diamond .. .. .	Hunt, H. B.
Crystals of gold .. .. .	Makins, G. H.
Hypersthene, seen with polarized light .. .. .	Matthews, Dr. J.
Carbonate of lime in carapace of Prawn .. .. .	"
Microscopical sections of rocks .. .. .	Rutley, Frank.
Various specimens of minerals, rocks, and meteorites, shown with 12 microscopes lent by Ross .. .. .	Sorby, H. C.
Specimens illustrating the application of the microscope to blow-pipe chemistry, shown with 12 microscopes lent by Crouch .. .. .	"
Microscopical sections of iron and steel, shown with 12 microscopes lent by B. and J. Beck .. .. .	"
Large specimen of Iceland spar .. .. .	Tennant, Professor.
Coal nodule .. .. .	Williams, J. R.

NEW APPARATUS, ETC.

Detached lever escapement in motion under Binocular Microscope .. .. .	Bate, Dr. G. P.
New form of Stephenson's Erecting Binocular Microscope .. .. .	Bevington, W. A.
Ditto ditto ditto adapting the principle to the Jackson model .. .. .	Browning, J.
Binocular Microscope, the stage fitted with mechanical adjustment, and provided with new centering adjustments by which the rotation of the stage can be instantly rendered perfectly concentric with any objective .. .. .	Crouch, Henry.
New form of apparatus and transparencies for showing drawings of microscopical objects in a dark room .. .. .	Hudson, Dr.
New apparatus for measuring the wave-length position of absorption bands in spectra .. .. .	Sorby, H. C.
A 1/10th object-glass, by Tolles, shown with a highly magnifying eye-piece .. .. .	Tupman, Capt.

SPECTRUM APPARATUS, ETC.

Diffraction Spectroscope .. .. .	Browning, J.
Various specimens illustrating the application of the Spectrum Microscope to mineralogy, biology, &c., shown with 12 instruments lent by Browning .. .. .	Sorby, H. C.

DRAWINGS, ETC.

Drawings of Rotifers, &c., &c. .. .. .	Hudson, Dr.
Enlarged drawings of Foraminifera .. .. .	Jones, T. R.
Diagrams illustrating the microscopical structure of rocks and minerals .. .. .	Rutley, Frank.



Drawings of 100 Foraminifera from the Dee .. .. .	<i>Shepherd, T.</i>
Photographs and drawings illustrating the potato disease, and the growth of Agarics .. .. .	<i>Smith, Worthington G.</i>
Lithographs of the microscopical structure of limestones, &c. ..	<i>Sorby, H. C.</i>
Microscopical photographs of iron and steel .. .. .	"
Drawing made with the pigments extracted from human hair.	"
Series of large diagrams illustrating the structure of various rocks, meteorites, &c. .. .. .	"
Drawings of microscopic objects .. .. .	<i>West, Tuffen.</i>
Cryptogamic studies .. .. .	<i>White, C. F.</i>
A series of photographs of the Holy Land, &c. .. .. .	<i>R. and J. Beck.</i>
A series of objects exhibited by Mr. C. Stewart under the Society's microscopes. (See "Animal Kingdom.")	
The Martin Microscope, belonging to the Society, by Mr. Slack; and a Reflecting Microscope on Amici's plan, by Cuthbertson; also the spectacles and other apparatus used by Robert Brown in his botanical researches.	

Mr. F. H. Ward has kindly supplied the following description of Mr. Bevington's microscope:—The microscope exhibited by Mr. Bevington is a modified form of stand to be used with the binocular arrangement of Mr. Stephenson. As this binocular is always used in one position, the axis for inclination has been done away with, and the instrument is supported by three legs firmly attached to the rectangular casting carrying the pinion of the coarse adjustment. The fine adjustment has been obtained by chasing a fine screw on the outside of the tube which receives the objectives, and this is acted on by a milled collar of large diameter immediately above them. The transverse arm, which usually contains the lever for the fine adjustment, has been done away with, and instead of it the upright piece with the rack of the coarse adjustment terminates in a cradle, in which the centres of the bodies are balanced and secured. This cradle revolves upon a cone, which in its turn revolves upon the conical extremity of the upright, and as the inside of the cone is turned excentric to the outside, by causing it to revolve the objective is carried either backwards or forwards over the stage, by revolving the cradle itself lateral movement of the objective is obtained, and by these means the rotating stage may be made perfectly concentric at any time, and then fixed by means of a screw. In the binocular of Mr. Stephenson with the usual stand oblique illumination cannot be obtained by moving the mirror to either side of the instrument, as the light would then fall on the prisms at different angles, and the fields of the eye-pieces would be unequally illuminated. Mr. Bevington has obtained the requisite obliquity by mounting the mirror on two brass rods which slide in two tubes, one on either side of the ring that slides up and down the main axis. The mirror has thus a range of about two inches in an antero-posterior direction. For centering, Mr. Bevington substitutes a cone terminating in a fine steel point for the objective, and secures on the stage a piece of smoked glass, or chalked wood, then revolving the stage a fine circle is described by this point, and after adjustment a dot only, and he believes that this is a better arrangement than any stage adjustment. There is also a lever which is made to embrace

the prism box, by which a very small movement may be imparted to it for the accurate adjustment of the prisms. There are minor details, but these are the principal features of the stand, which is particularly steady and free from vibration.

Mr. Browning's adaptation of the Stephenson instrument to the Jackson model renders it available for those who wish to use it with a stand of that pattern. The images of the object are reflected to the eye-pieces by two silvered flats, so carefully worked as not to injure the definition.

Dr. Hudson's transparencies, consisting of beautifully executed drawings of rotifers, were illuminated from behind, and produced an excellent effect, which was enhanced by eloquent verbal descriptions that attracted large audiences. Mr. Tisley exhibited in the same theatre Mr. Spottiswoode's splendid polariscope apparatus, and Messrs. How and Co. showed fine micro-photographs with the oxy-hydrogen microscope.

Donations to the Library since April 5, 1876 :

Nature. Weekly .. .. .	From <i>The Editor.</i>
Athenæum. Weekly .. .. .	<i>Ditto.</i>
Society of Arts Journal. Weekly .. .. .	<i>Society.</i>
The Twenty-first and Twenty-second Annual Report of the Brighton and Sussex Natural History Society, 1874-75.	<i>Ditto.</i>
Water-colour Drawing of <i>Bowerbankia</i> .. .. .	<i>W. T. Suffolk, Esq.</i>

Mon. Rénard and Dr. William Osler were elected Fellows, and Count Castracane an Honorary Fellow of the Society.

WALTER W. REEVES,  
*Assist.-Secretary.*

WATFORD NATURAL HISTORY SOCIETY.

Ordinary Meeting, March 9, 1876.—Dr. A. T. Brett, Vice-President, in the chair.

Mr. Arthur Cottam, F.R.A.S., delivered a lecture "On some of the Simpler Methods of Microscopical Mounting," which he illustrated practically by mounting objects dry and in Canada balsam.

In treating of the cements employed in dry mounting, he stated that gum-water should be made with perfectly cold water, with a small quantity of alcohol and a little glycerine added; that a mixture of india-rubber, asphalte, and mineral naphtha formed the best cement; and that Canada balsam was not to be relied on at all, becoming brittle.

As an illustration of mounting in Canada balsam, he mounted some diatoms, taking a glass slide, subjecting the diatoms to a dull red heat, placing them in a medium consisting of two parts of balsam to one of benzole, slightly heated, and dropping on the thin glass cover, having previously warmed the slide to prevent its cooling the balsam suddenly, and so producing air-bubbles.

He stated that the chief difficulties in these simple methods of mounting were to get rid of moisture and air-bubbles; it was more necessary to get rid of moisture when mounting in balsam than dry, and more difficult to get rid of air-bubbles in glycerine jelly—a favourite and very useful medium—than in balsam.

He recommended Mr. Davies' work, in the Society's library, as the best guide to microscopical mounting.

It was announced that field meetings had been arranged, in conjunction with the Quekett Microscopical Club, for June 3 at Bricket Wood, and for July 1 at Elstree Reservoir and Stanmore Heath.

#### SAN FRANCISCO MICROSCOPICAL SOCIETY.

The regular meeting of the San Francisco Microscopical Society was held on Thursday evening, April 6.

Dr. Blake placed on the stage a slide mounted temporarily with some living specimens of phylloxera taken from the root of a vine in Sonoma county. In addition to the smaller type of insect, which does the injury to the vines, there was one specimen of what he stated was the nymph form of the same, and to which he called special attention, from the fact that in Europe this stage in the life history of the pest is not met with till as late as July or August. He remarked that he could detect no wings or sucker, but found several large ova in the body, which in Europe developed into the sexual insect, which lays a single egg, hibernating till spring. Whether the one before the Society would have produced the mother lice, under favourable circumstances, he was not prepared to say. Some of the remedies suggested to the vine-growers by Dr. Blake had been tried, but unfortunately had proved of no avail in staying the development or ravages of this troublesome insect. It would seem from the above that our vine-dressers must prepare for a vigorous prosecution of the war, and that the spring campaign will open early.

In this connection it may be well to state that it appears, from reports supplied to the French Academy, that the most efficacious remedies for vines attacked with the phylloxera are alkaline sulpho-carbonates, that of soda being the most effective. It is applied in solution, and destroys the insects without injuring the vine.

Dr. Wythe referred to the amplifiers he exhibited at the last meeting, and stated that he had succeeded in getting excellent definition with them, when used with very high powers; and further, that he had adapted the same to his Crouch binocular. A new illuminator was described by him, and which he had constructed with a right-angled prism, a plano-convex lens cemented to one face, and an ordinary French triplet attached to the other side, at a point near the angle. This gave him, by the slightest tilt out of a line perpendicular to the object, an extreme obliquity of light, and which was at the same time entirely achromatic.

Mr. Charles Stodder, of Boston, wrote the Society some facts concerning the  $\frac{1}{10}$ th objective of Tolles.

---

## INDEX TO VOLUME XV.

## A.

- ABERRATION**, on the Characters of Spherical and Chromatic, arising from Excentrical Refraction, and their relations to Chromatic Dispersion. By Dr. ROYSTON-PIGOTT, F.R.S., 128.
- Address, the President's.** By H. C. SORBY, F.R.S., 105.
- Algae, Unicellular, parasitic within Fossil Corals.** By Prof. M. DUNCAN, 143.
- Angular Apertures of Object-glasses, on the Measurement of the.** By JABEZ HOGG, M.R.C.S., &c., 266.
- ANTHONY, Dr. JOHN,** Note on Dr. Woodward's paper on the Markings of the Body-scale of the Gnat and Mosquito, 256.
- B.**
- Bacteria, Presence of, in the Walls of Hospital Wards,** 33.
- found in the Perspiration of Man, 34.
- BALBIANI, M.,** on the Embryogeny of the Flea, 140.
- Beetle's Eye, on a Mode of viewing the Seconds' Hand of a Watch through a** By Dr. WHITTELL, 136.
- BENNETT, ALFRED W., M.A.,** the Absorptive Glands of Carnivorous Plants, 1.
- BLAKE, J. F.,** on *Renulina Sorbyana*, 262.
- Blood, the Circulation of, in the Frog's Lung,** 142.
- **Corpuscles, Form and Size of the Batrachian,** 93.
- — Examining the, 94.
- — the Emigration of, 276.
- **Globules in Typhoid Fever,** 233.
- **Stains, Improved Method of applying the Micro-spectroscopic Test for.** By Jos. G. RICHARDSON, M.D., 30.
- BROECK, M. ERNEST VANDEN,** on a New Microscopic Slide, 221.
- BROWN, Mr. J. A.,** on the Measurement of Nobert's Bands, 273.

## C.

- Carbonic Acid, the Identification of Liquid in Mineral Cavities.** By WALTER NOEL HARTLEY, F.C.S., 170.
- CARTER, Mr. H. J.,** on the Difficulties of Classification of the Spongida, 238.
- Cell, a Growing, adapted for supplying Moist Air,** 198.
- Cells, Structure of the Pancreatic, observed during Digestion,** 228.
- Chara, Production of the Prothallus from the Spore of,** 145.
- Cholera, Microscopic Examination of the Intestines in cases of,** 142.
- Collomia coccinea, the Seeds of,** 145.
- Controversy by Tyndall and Bastian,** 146.
- Corals, Vegetable Parasites in,** 93.
- **Unicellular Algae parasitic within Fossil.** By Prof. M. DUNCAN, 143.
- Corpuscles, the Migrations of the White.** By Dr. JUL. ARNOLD, 34.
- Correspondence:—**
- AKAKIA,** 101.
- BRANWELL, R.,** 43.
- BROOKE, CHARLES,** 45, 201.
- F.R.M.S.,** 48, 49.
- GORDON, M. J.,** 41.
- GRIFFIN, F. W., M.D.,** 95, 242.
- HASERT, B.,** 95.
- HICK, THOMAS, B.A.,** 156.
- HUGHES, RICHARD,** 52.
- JOHNSTON, CHRISTOPHER, M.D.,** 44.
- JONES, Professor R.,** 200.
- KEITH, R.,** 199.
- KITTON, F.,** 51, 52.
- MAYALL, J., jun.,** 51, 97.
- MOREHOUSE, G. W.,** 40.
- PIGOTT, G. W. ROYSTON-,** 100.
- SHADBOLT, GEORGE,** 202.
- SMITH, H. L.,** 278.
- TOLLES, R. B.,** 281.
- WENHAM, F. H.,** 45, 46, 47, 48, 151, 241.
- Crustacea, the supposed Renal Organ in.** By Mr. A. S. PACKARD, jun., 35.

Crustacean, a New Phyllopodous, 137.  
Cryptogams, a New Classification of.  
By Professor J. SACHS, 270.

American Mosquito. By Dr. J. J.  
WOODWARD, 253.  
GULLIVER, Mr. G., on the Spermatozoa  
of the Petromyzon, 33.

[www.libtool.com.cn](http://www.libtool.com.cn)

DALLINGER, Rev. W. H., on a New  
Arrangement for Centering and  
Illuminating with High Powers, 165.  
Diatomeen-Probe-Platten, the Mea-  
surements of Möller's. By E. W.  
MORLEY, 223.

Diatoms, the Examination of Coal for,  
137.

— Dr. WOODWARD on the Spurious  
Lines of, 144.

### F.

Fish, Characters of the Slime of Phos-  
phorescent, 270.

Fishes: the Roots of the Spinal Nerves  
in Elasmobranch Fishes, 235.

Flea, the Embryogeny of the. By M.  
BALBIANI, 140.

Foraminifera, Remarks on the, with  
especial reference to their Variability  
of Form, illustrated by the  
Cristellarians. By Professor RUPERT  
JONES, F.R.S., 61, 200.

— of the Chalk, Instructions for  
Cleaning, 241.

Frustulia Saxonica, Navicula rhom-  
boides, and Navicula crassinervis.  
By CHARLES STODDER, U.S.A., 265.

— H. L. SMITH on, 278.

— Further Notes on. By W.  
J. HICKLE, M.A., 122.

### G.

Ganglia, Relations of Nerves to, 228.

GAYER, Surgeon-Major E. J., Notes on  
Micro-photography, 258.

GILES, G. M., Avoiding the Heliostat  
in Micro-photography, 26.

Gland, Nerve-supply to the Thyroid,  
231.

— the Minute Anatomy of the Thy-  
roid, 232.

Glands, the Absorptive, of Carnivorous  
Plants. By ALFRED W. BENNETT,  
M.A., 1.

Glycerine, the best Cement with, 197.

Gnat, on the Markings of the Body-  
scale of the English, and the

### H.

Hæmatococcus lacustris, the Develop-  
ment of, 196.

Hæmoglobin, the Evolution of, 149.

HARTLEY, WALTER NOEL, on the Iden-  
tification of Liquid Carbonic Acid in  
Mineral Cavities, 170.

Heliostat in Micro-photography, avoid-  
ing the use of the. By G. M. GILES,  
26.

HICKLE, W. J., M.A., Further Notes on  
Frustulia Saxonica, 122.

— on Zeiss'  $\frac{1}{3}$ th Immersion,  
185.

HOGG, JABEZ, on the Measurement of  
the Angular Apertures of Object-  
glasses, 266.

Hyrax, the Placentation of, 235.

### I.

Illuminating and Centering with High  
Powers, a New Arrangement for.  
By Rev. W. H. DALLINGER, 165.

Insects, the Secreting Organs of the  
Alimentary Canal in, 269.

### J.

JONES, Professor RUPERT, F.R.S., Remarks  
on the Foraminifera, with  
especial reference to their Variability  
of Form, illustrated by the Cristel-  
larians, 61, 200.

### L.

Lactate of Silver as a Colouring Agent.  
By M. ALFEROW, 38.

Lens, Browning's Platyscopic, 37.

Lepas fascicularis, the Development of,  
and the "Archizoëa" of Cirripedia.  
By Dr. R. VON WILLEMÖES-SUEHM, 137.

### M.

Micrococcus and Bacteria, Presence of,  
in the Walls of Hospital Wards, 33.

Micro-photography, Notes on. By Sur-  
geon-Major E. J. GAYER, 258.

- Microscopy at the American Association, 278.
- Mollusks, the Development of Gastro-pod, 238.
- MOREHOUSE, Mr. G. W., on Silica Films and the Structure of Diatoms, 38.
- MORLEY, E. W., of Hudson, Ohio, the Measurements of Möller's Diatomaceen-Probe-Platten, 223.
- Mosquito, on the Markings of the Body-scale of the American. By Dr. J. J. WOODWARD, 253.
- Mounting, a Concentrated Mode of, 151.
- Mushroom Tribe, Reproduction in the. By WORTHINGTON G. SMITH, F.L.S., 6.
- N.
- Navicula rhomboidea, Note on the Markings of. By Dr. J. J. WOODWARD, 209.
- Nervous System, a New Mode of Colouring Sections of the, 228.
- Nobert's Bands, the Measurement of. By Mr. J. A. BROWN, F.R.S., 273.
- O.
- Object-glasses, on the Aperture of. By F. H. WENHAM, 184.
- How to Measure the Angular Aperture of, 236.
- Objectives, an Improved Method of Numbering, 197.
- of Seibert, New Formula, 198.
- Obsidian, Perlite, and Leucite, on some Structures in. By FRANK RUTLEY, F.G.S., 176.
- Ostracoda, to Mount, in a Permanent Manner, 150.
- P.
- PACKARD, Mr. A. S., jun., on the supposed Renal Organ in Crustacea, 35.
- Paresis, State of Chord in Death from, 238.
- Petromyzon, the Spermatozoa of. By Mr. G. GULLIVER, 33.
- Phylloxera, a New Form of the, 277.
- PIGOTT, Dr. ROYSTON, F.R.S., on the Characters of Spherical and Chromatic Aberration arising from Eccentric Refraction, and their relations to Chromatic Dispersion, 128.
- Plants, the Absorptive Glands of Carnivorous. By A. W. BENNETT, M.A., 1.
- and Animals, the Relations between, 144.
- Lignin in, 234.
- Postal Micro-Cabinet Club, the American, 240.
- Potato Disease, the, 269.
- Prickle-cells in the Wall of the Stomach of certain Animals, 145.
- PROCEEDINGS OF SOCIETIES:—
- Adelaide Microscopical Club, 249.
- Fairmount Microscopical Society, 252.
- Medical Microscopical Society, 58, 104, 247.
- Memphis Microscopical Society, 60.
- Quekett Microscopical Club, 59, 206, 248.
- Royal Microscopical Society, 53, 56, 101, 157, 203, 244, 282, 285.
- San Francisco Microscopical Society, 252, 290.
- South London Microscopical and Natural History Society, 207.
- Watford Natural History Society, 289.
- Prothallus from the Spore of Chara, the Production of, 145.
- R.
- RÉNARD, Mons. A., S.J., some Results of a Microscopical Study of the Belgian Plutonic Rocks, 212.
- Renulina Sorbyana, on. By J. F. BLAKE, 262.
- RICHARDSON, Jos. G., M.D., Improved Method of applying the Micro-spectroscopic Test for Blood-stains, 30.
- Rocks, some Results of a Microscopical Study of the Belgian Plutonic. By A. RÉNARD, S.J., 212.
- RUTLEY, FRANK, F.G.S., on some Structures in Obsidian, Perlite, and Leucite, 176.
- S.
- Salpa spinosa, Egg and Bud Development of, 146.
- Sarcomas, on the Development of Spindle-cells in Nested. By Dr. GOWERS, 271.
- Saxifraga tridactylites, the Leaf Glands of. By Mr. J. C. DRUCE, 33.
- Sections, on Staining and Mounting Wood. By M. H. STILES, 133.