

www.libtool.com.cn

Henry Burden

ng
16
.5

www.libtool.com.cn

HARVARD COLLEGE
LIBRARY



FROM THE FUND OF
CHARLES MINOT

CLASS OF 1828

www.libtool.com.cn

www.libtool.com.cn

to ~~4000~~

www.libtool.com.cn

$\frac{a\beta}{250}$

Penetration test

~~31~~ 

www.libtool.com.cn

www.libtool.com.cn

www.libtool.com.cn

www.libtool.com.cn



*Henry Burden.
From a miniature painted in London in 1828 now in the
possession of Mrs. Jessie Burden Wadsworth.*

www.libtool.com.cn

www.libtool.com.cn

HENRY BURDEN

www.libtool.com.cn

HIS LIFE

**AND A HISTORY OF HIS INVENTIONS
COMPILED FROM THE PUBLIC PRESS**

**BY HIS DAUGHTER
MARGARET BURDEN PROUDFIT**

**TROY NEW YORK
1904**

✓ E-g 76.11.5

www.libtool.com.cn

HARVARD COLLEGE LIBRARY
MINOT FUND

Jan 17, 1927

Pafraets Press Troy, New York 1904

www.libtool.com.cn

HENRY BURDEN

SKETCH OF HIS LIFE AND INVENTIONS — THE SPIKE
MACHINE — THE GREAT WATER WHEEL — THE
CONCENTRIC SQUEEZER — THE HORSESHOE MACHINE
— INTERESTING INCIDENTS IN HIS CAREER

www.libtool.com.cn

LIST OF ILLUSTRATIONS

HENRY BURDEN (MEZZOTINT) *Frontispiece*

BURDEN FAMILY VAULT

HENRY BURDEN, INVENTIVE AGE

WOODSIDE CHURCH

THE WATER WHEEL

WOODSIDE RESIDENCE

MILLS ON THE WYNANTSKILL

HENRY BURDEN

RIVER MILLS AND BLAST FURNACE

www.libtool.com.cn

HENRY BURDEN

HENRY BURDEN was born at Dunblane, Scotland, April 22, 1791. His father was a small farmer; and it was while a youth, engaged on the farm, that the son gave evidence of inventive genius, by making with his own hands labor-saving machinery from the roughest materials, with but few tools and no models. His first marked success was in constructing a threshing-machine. He afterward engaged in erecting gristmills and making various farm implements. During this period he attended the school of William Hawley, an accomplished arithmetician; and afterward, having resolved to try his fortunes in America as a machinist and inventor, he went to Edinburgh and entered upon a course of studies embracing mathematics, engineering, and drawing. Arriving in this country in 1819, he devoted himself to the improvement of agricultural implements. His first effort was to make an improved plow, which took the first premium at three county fairs. In 1820 he invented a cultivator, which was among the first, if not the first, ever put in practical operation in this country. In 1822 he took his first patent, which was for a hemp and flax machine. In the same year he removed from Albany to Troy, where he became the agent of what was then known as "The Troy Iron and Nail Factory," then a comparatively insignificant concern. For a period of over forty years he devoted himself to the development of this establishment. From the position of superintendent, Mr. BURDEN gradually made his way upward until he became sole proprietor. Numerous and extensive additions were made by him to the works; and these and other works erected and put into successful operation in the neighborhood are now among the most important industrial establishments in the country.

In 1825 Mr. BURDEN received his first patent for making wrought nails and spikes, and in 1834 another patent for an improved machine for the purpose was issued to him. In the same year he took a patent for a furnace for heating bar-iron, and another for an improvement in the construction of steam-boats. In the following year he obtained his first patent in the manufacture of horseshoes, the fame of which and subsequent improvements upon machinery for this manufacture, patented in 1843, 1857, and 1862, has become world-wide. The improved machines make 3,600 shoes per hour, and may be regarded as one of the greatest triumphs in mechanics.

In 1840 Mr. BURDEN obtained a patent for a machine for rolling puddle-balls in the manufacture of wrought-iron, known as the "rotary squeezer," which is considered one of the most important machines in the iron manufacture, and is now in almost universal use. In the same year he patented the "hook-headed spike," now used upon every railway in the country. His suits against Messrs. Corning and Winslow, for infringement of this patent, commenced in 1842 and extending in 1867 — running through a quarter of a century — will always rank among the *causes célèbres* in American patent law. For thirteen years the matter was in the hands of a referee, whose charges amounted to about \$60,000. The expenditure for lawyers' fees must have been enormous, but the total amount realized for damages was inconsiderable, though the patent was sustained.

A patent was obtained by Mr. BURDEN in 1849, for improved machinery for rolling puddled iron into bars, and in the same year he obtained an extension for the further term of seven years of his horseshoe patent of 1835. In 1854 his patent of 1840 for the "rotary squeezer" was extended for seven years. His last patent was that for the final improvement on the horseshoe machine. The patents we have referred to — twelve in number — were all he obtained. Their number is inconsiderable compared with those obtained by many inventors, but they are among the most important in the history of the industrial arts.

He was at one time much interested in navigation. In 1833

he built a "cigar boat," 300 feet long, with paddle-wheels thirty feet in diameter, and its inventor had great faith in it, but it was lost on the trial trip through the mismanagement of the pilot. The loss entailed upon Mr. BURDEN was most severe, and though he had every faith in the principle upon which the boat was constructed, he never made another experiment in that direction. In 1836 he turned his attention to ocean navigation, and warmly advocated the construction of a line of steamers of 15,000 tons burden. When, in 1845, the steamship Great Britain was crippled by the breakage of one of her screw-blades, Mr. BURDEN went to England for the special purpose of inducing her owners to adopt the side wheel, but his efforts were unsuccessful. His views on ocean navigation becoming known to some gentlemen in Glasgow, who, like him, felt a deep interest in the subject, they, with his permission, issued a prospectus for "Burden's Atlantic Steam Ferry Company," in which was advocated the establishment of a line of steamers of enormous dimensions. This project anticipated by several years the Great Eastern.

Some idea of the magnitude of the iron works at Troy under his control may be had when it is stated that in the year 1864 the number of men employed was 1,200, the cost of iron, coal, and other raw material was over a million and a half of dollars, and the manufactured products turned out amounted in value to over three millions.

In person Mr. BURDEN was large and well made, with a large head, and prominent though regular features, a wide and high forehead, overhanging, deep-set eyes, and a mouth which usually had a cheerful, kindly expression. His appearance, as may be seen in the portrait, was remarkable and venerable. His mental faculties were unimpaired to the last, and his physical vigor remarkable for a man of fourscore. Some time ago it had been intimated to Mr. BURDEN by his physician that his disease, which was an affection of the heart, was liable to terminate his life at any moment, and he at once made his will and otherwise arranged his earthly affairs.

The estimation in which Mr. BURDEN was held where he was

best known may be judged of by the following remarks, which appeared in a local contemporary on the day of his death:

"The sudden and afflicting event of course produced a great sensation throughout the city. Rapidly the news was communicated from mouth to mouth, and among all classes it caused a feeling of sorrow such as no similar event in years has occasioned. Among the men employed in his extensive iron-works, the emotion was indeed great. Each man felt as if he had not only lost a friend, but a protector. The beautiful Woodside Presbyterian church, which he erected at his own expense, will tell the story of his love to God and man; but the daily acts of benevolence that he performed also testify to his Christianity, and are perhaps his surest passports to the bliss of eternity."—*Phrenological Journal*, April, 1871.

www.libtool.com.cn

SUDDEN DEATH OF HENRY BURDEN

SKETCH OF HIS LIFE

www.libtool.com.cn

HENRY BURDEN

Our pen almost refuses to write the sad words — **HENRY BURDEN IS DEAD!** And yet this eminent man, this distinguished inventor, this great worker and manufacturer, is no more. He closed his earthly career, full of honors and of years, at about 11 o'clock this morning — dying suddenly, without a murmur or a struggle, and so peacefully and gently that when his daughter, Mrs. Proudfit, went into his room and found him lying upon the sofa she supposed him to be asleep. Alas, it was the repose of death. Mrs. Proudfit drove down from her residence in the city to Mr. BURDEN's elegant mansion overlooking his extensive iron works, about 10 o'clock, and upon entering the house inquired of a servant where her father was. "In his room," was the reply, and into it she passed. Going up to her father, she bent over his body, at the same time remarking to him, "Are you asleep, father?" Stooping down, she imprinted a kiss upon his lips, only to find them cold and stilled forever in death. This was the first intimation that any of the family had that he was dead. Telegrams were sent up from the works for the family physician, Dr. Seymour, who immediately repaired to Mr. BURDEN's residence, but of course he could do nothing — a greater than he had stilled the beating heart and throbbing brain, and it was not in the power of man to endow them with life again. The disease of which Mr. BURDEN died was doubtless a difficulty of the heart.

The sudden and afflicting event of course produced a great sensation throughout the city. Rapidly the news was communicated from mouth to mouth, and among all classes it caused a feeling of sorrow such as no similar event in years has occasioned. Among the men employed in his extensive iron works, the emotion was indeed great. Each man felt as if he had not only lost a friend, but a protector.

We have not time to-day to write a fitting biography of the deceased. His life has been so useful, and his work so varied and

important, that we can do no more than sketch them rapidly and imperfectly.

Mr. BURDEN was born at Dunblane, Scotland, April 22, 1791. His father was a small farmer, and it was while a youth engaged on the farm that the son gave evidence of inventive genius, by making with his own hands labor-saving machinery from the roughest materials with but few tools and no models. His first marked success was in constructing a threshing machine. He afterward engaged in erecting grist mills and making various farm implements. During this period he attended the school of William Hawley, an accomplished arithmetician, and afterward, having resolved to try his fortunes in America as a machinist and inventor, he went to Edinburgh and entered upon a course of studies, embracing mathematics, engineering, and drawing. Arriving in this country in 1819, he devoted himself to the improvement of agricultural implements. His first effort was in making an improved plough, which took the first premium at three county fairs. In 1820 he invented the first cultivator ever used in this country. Two years afterward he was appointed agent of what was then known as "The Troy Iron and Nail Factory." In 1825 he received a patent for his machine for making wrought-iron spikes, and in 1834 another patent for an improvement on the machine was issued to him. In 1835 Mr. BURDEN, after directing many years to the perfection of the machine, procured a patent for making horseshoes by machinery. This is the most successful and best known of his inventions. Its fame is world-wide. When it was introduced to the public it was looked upon, as such inventions generally are, with distrust, but it gradually grew into public favor, and to-day it is recognized as one of the most important inventions of the century. In 1840 a patent was issued to him for an invention called "the hook-headed spike," out of which grew the famous suits between himself and the proprietors of the Albany Iron Works. The suits were in litigation many years, and were only recently adjudicated. The hook-headed spike is now used upon every railroad in this country. In 1849 he invented a self-acting machine for rolling puddled iron into bars. From then until 1857 he devoted himself to the direct super-

intendency of his works in the southern end of the city. From the position of superintendent, he gradually made his way upward, until he became sole proprietor. Numerous and extensive additions were made to them, until to-day they take a front rank among the industrial establishments of the country. In the month of June, 1857, he patented his improvement upon the horseshoe machine. This may be considered his greatest triumph in mechanics; it is self-acting and produces from the iron sixty horseshoes per minute. This we believe concludes the list of Mr. BURDEN's patented inventions.

Mr. BURDEN was at one time much interested in navigation. In 1853 he built the first "cigar boat" ever constructed. The craft was three hundred feet long, with paddle-wheels thirty feet in diameter, and its inventor had great faith in it. But it was lost on the trial trip through the mismanagement of the pilot. The loss entailed upon Mr. BURDEN was most severe, and, though he had every faith in the principle upon which the boat was constructed, he never made another experiment in that direction. In 1836 he turned his attention to ocean navigation, and warmly advocated the construction of a line of steamers of 15,000 tons burden. When, in 1845, the steamer "Great Britain" was crippled by the breakage of one of her screw-blades, Mr. BURDEN went to England for the especial purpose of inducing her owners to adopt the side wheel, but his efforts were unsuccessful. His views on ocean navigation becoming known to some gentlemen in Glasgow, who, like him, felt a deep interest in the subject, they, with his permission, issued a prospectus for "Burden's Atlantic Steam Ferry Company," in which was advocated the establishment of a line of steamers of enormous dimensions. This project anticipated by several years the Leviathan, or Great Eastern.

Mr. BURDEN leaves behind him two sons, James and Townsend, who have for some time past conducted the works established by their father, and who will doubtless continue them; also three daughters, Mrs. Gen. McDowell, Mrs. Proudfit, of this city; Mrs. Wadsworth, of Buffalo, and numerous grandchildren. Two sons, Peter and William Burden, and his excellent and truly Christian wife, have preceded him to the grave — William dying about

three years since quite suddenly. Some time since, we understand, it was intimated to Mr. BURDEN by his physician that his disease was liable to terminate his life at any moment. He at once arranged his earthly affairs, and among other preparations made a will, which, it is understood, divides his extensive property equally among his children. Gen. McDowell is appointed one of the trustees of the estate.

HENRY BURDEN ranked among the foremost of American inventors, and his name will descend to succeeding generations along with the names of Fulton and Morse, and other benefactors of mankind. The workshops that line the Wynantskill are monuments of his skill, his industry, and enterprise. Few men have done more for the world than he; and, best of all, he goes down to the grave with a memory that will be forever precious, fragrant as it is with goodness, benevolence, and philanthropy. The beautiful Woodside Presbyterian Church, which he erected at his own expense, will tell the story of his love to God and man; but the daily acts of benevolence that he performed also testify to his Christianity, and are perhaps his surest passports to the bliss of eternity.—A CITY IN GLOOM — *Troy Daily Times, Thursday Afternoon, January 19, 1871.*

www.libtool.com.cn

www.libtool.com.cn

www.libtool.com.cn



Henry Burden.

www.libtool.com.cn

HENRY BURDEN

HENRY BURDEN, whose death was announced in the "Times" of last evening, had done so much for this community, and his life was so full of interest, and so fraught with example and encouragement to the young, and our tribute to his memory yesterday was so imperfect, that we feel it to be our duty to review more at length the work he accomplished in this community. Any tribute that we could pay him would at best be feeble and unsatisfactory. Fortunately, he needs no encomiums at our hands. His life is its own best eulogy. Its story truly told tells of a man who has done more for Troy than perhaps any five men in it. Principally through his efforts all the vacant farm lands in the southern portion of the city have been built over and are made to hum with the busy notes of industry; the waters of the Wyanntskill, but partially harnessed to the car of progress and mostly all running to waste when Mr. BURDEN came here, are now utilized and made to do full work in the service of mankind: indeed, they have been so overtaxed with increasing workshops and mills, that these forces of nature have become wholly inadequate to the wants of our manufacturers, and a more reliable agency has been invoked to carry on the gigantic operations which have grown up from the little beginning that had been made when HENRY BURDEN first settled in our city. From the single grist mill, carding machine, and the little iron establishment that stood upon the site of what is now the Troy Iron Works, and barely fretted the waters, there have now come to be great iron manufactories, employing upward of 3,000 operatives, and giving support to at least one-eighth of the population of Troy. Mr. BURDEN came to America in 1819, and until 1822 had a business connection with the Messrs. Townsend and Erastus Corning, of Albany. In the latter year he came to Troy, and succeeded John Converse in the superintendence of the mill known as the "Troy Iron and Nail Factory." The establishment was owned by a stock company.

with a capital of \$96,000. The little mill they owned contained a single pair of rollers, coupled to two water wheels, one at each end, and connected with them as if upon a shaft. The water supply then was most fitful and unreliable, and Mr. BURDEN at once directed his attention toward making it more certain throughout the year. He originated a system of reservoirs along the stream to hold the water in reserve, and thus for many years the Wyanntskill was able to furnish all the power that was need by the works upon its banks. Out of this beginning have grown not only the large water mill but the great blast furnaces and steam mills, and also the Rensselaer Iron Works, for these last were built and put in operation by a firm of which the eldest son of Mr. BURDEN (Peter A.) was the managing partner, and subsequently they became the sole property of Mr. BURDEN, though now owned by J. A. Griswold & Co. No vestige of the original establishment which Mr. BURDEN founded here in 1822 now remains — everything that is to be seen there grew up under Mr. BURDEN'S direction or ownership. More than forty years of his life were spent in labors, mental and physical, for the advancement of the interests of the establishment. An accomplished mechanic, he could make a better piece of work than any man he could find in his shops; he could deal a heavier blow with the sledge than any of his strikers at the forge. Thus physically favored, his business forecast was only equaled by his genius for invention, and his productions and triumphs are acknowledged everywhere as among the most important and revolutionary yet known to the history of iron manufacture. Mr. BURDEN'S first invention after taking charge of the Troy Works was his

FIRST SPIKE MACHINE.

There were many obstacles encountered in bringing this machine to the favor of purchasers. Shipbuilders had a prejudice against it. They would not believe that a spike made by machinery would be as valuable as a spike made by hand, even when it in fact was a better article. As railroads came to be constructed, the counter-sunk spike for the flat rail gained an extensive mar-

ket, and the popular prejudice gradually wore off. In the winter of 1835-6 Mr. BURDEN visited England and ascertained that the flat rail was to be superseded by the "T" and "H" rail, and that consequently another and new variety of machine-made spikes would be the most marketable. He at once made the drawings for a modification of the original spike machine, designed so that from it might be produced what is now known as the hook-headed spike. He made ten tons of this kind of spikes for the Long Island Railroad Company, as his first contract, in 1836. It was not until 1840 that he obtained a full patent for the machine. If anywhere machine hook-headed spikes have been found, it is certain that they have been made at the works of the BURDEN'S, or in contempt of a decision of the United States Supreme Court, which has decided beyond appeal the question of invention and patent right in Mr. BURDEN'S favor. The litigation which ensued in relation to this patent is among the most memorable in the history of the jurisprudence of this country. It lasted nearly twenty years, and some of the most distinguished lawyers in the United States — William H. Seward, Nicholas Hill, Chancellor Walworth, David L. Seymour, and, we believe, Daniel Webster — being engaged in it. At this time he was half owner of the Troy Iron Works, which had grown to be an extensive enterprise.

In 1838-9 Mr. BURDEN constructed the immense water-wheel which Lewis Gaylord Clarke has called the "Niagara of water wheels." It is an overshot sixty feet in diameter, and the power of the wheel is graduated to any point between one-horse power and 700. With one exception — a wheel in Greenock, Scotland — this is the largest water-wheel in the world. In preparing for the manufacture of iron from the pig Mr. BURDEN, by a simple contrivance, created a revolution in the process of manipulating the metal between the puddling furnaces and the rolls. This had been done by means of a hammer. When the great wheel and its connections had been located, the millwright discovered that there was no place provided for the hammer in vogue at that time. He reminded Mr. BURDEN of the omission, and received the reply: "On no account would I use one." On passing from his break-

fast table to his works he conceived the idea of revolving and compressing the puddle balls between concentric surfaces. This invention is termed the "rotary concentric squeezer," which the Commissioner of Patents declared was the first truly original and the most important invention in the manufacture of iron at that time that had been produced at the patent office. He made the working model with his own hands, and putting the pieces of this model in his pocket he thought no more of the subject until at the dinner table after dessert, when he exhibited them to his young sons with the remark, "There is something new; guess what it is for." No one was able to guess, but all desired an explanation. Mr. BURDEN replied, "I intend to apply it to the manufacture of iron." A gentleman visitor, with the model in his hand, skeptically remarked: "We are not quite so green as to swallow that, Mr. BURDEN." Mr. BURDEN then took a piece of putty, put it into the shape of a puddle ball, placed it between the flanges of the model, and by a rapid shove of the upper over and upon the other, a beautiful miniature bloom whirled across the table, the result causing the unbelieving gentleman to exclaim, "Mr. BURDEN, we give in." The principle of this model to this day has never been changed. And wherever there is a puddling furnace and pair of rolls there the squeezer will be found, and it has probably saved more in the manufacture of wrought-iron than any other machine ever invented. Go where you will in this country, in Great Britain, or on the Continent, you find BURDEN'S rotary squeezer. When the question of the renewal of the patent was considered, some years since, it was shown, upon the testimony of Pittsburg iron men, that during the short time it had been used in that city it had resulted in the saving of \$530,000.

THE HORSESHOE MACHINE.

After years of study and experiment, Mr. BURDEN set up his first horseshoe machine in 1834, and a patent was issued for it in 1835. This he considered the most important invention of his life. In 1843 he improved upon the original machine, reducing its operations to two movements, and in 1857 he perfected and

patented his present machine, which devours the heated bar, cuts, bends, and forges it into perfect shape with one movement, at the rate of sixty a minute, or thirty-six hundred shoes per hour. This invention has a great political as well as a commercial importance. Iron-workers will recollect that the little Mexican war of 1847 caused an advance in the price of horseshoes to fifty cents per pound, and it was difficult to obtain a sufficient supply at that. In the war of the Crimea the countries participating experienced much greater inconvenience from a similar difficulty. During the War of the Rebellion the BURDEN works supplied all the horseshoes used in the Federal armies, and it is difficult to see how, in the absence of this invention, the great necessity could have been met. At first the rebels obtained their supplies of shoes from the depots and trains captured from the Union armies, but after the war had progressed for a couple of years, when rebel successes had become less frequent, their supply was of course diminished, and they felt the importance of supplying by other means their necessity. The rebel government employed a man by the name of Moses, a co-operator with Saunders, Thompson, and others of that class to come to the North, steal the pattern of this horseshoe machine and smuggle it into Canada, with a view to the ultimate establishment of a horseshoe factory at Atlanta for the benefit of the rebel confederacy. As it happened, Sherman's operations spoiled that game. Foreign governments as well as our own appreciate the importance of this invention, and England, France, Austria, Prussia, Russia, and other powers have availed themselves of it. An idea of the impression received by the ignorant and superstitious population of Central Europe upon witnessing the operation of this machine may be obtained from the following incident: One of the machines for the Austrian government was to be set up and put in operation in Styria. The government was to supply such labor aid as might be desired, and when operations commenced in putting the machine up so great was the curiosity that ropes and guards had to be placed in order to keep the crowd sufficiently back to prevent interference with the work. It was so day after day until the machine was ready and commenced operations. It started off successfully, throwing out the shoes

more rapidly than the crowd could count them. But they did not stop to count, for, regarding the thing as a supernatural monster, the spectators fled the premises in the wildest confusion, and but few of them again appeared during the stay of the American party.

Mr. BURDEN's interest in the Troy Iron Works at different times is shown by the following facts: He acquired shares as they were obtainable, until in 1835 he owned about half of the stock. At this time thirty per cent. of the net earnings of the entire works was given him for his spike and horseshoe inventions, which were assigned to the corporation. In 1840 the entire interest had been acquired, and the establishment has since been run in his own name or under the firm name of HENRY BURDEN & SONS.

RESOLUTIONS OF THE BOARD OF TRADE.

At the meeting of the Board of Trade last evening, Hon. James Forsyth, after adverting eloquently to the character of Mr. BURDEN and the work he had performed, offered the following resolutions, which were unanimously adopted:

WHEREAS, This Board has heard with emotions of undisguised sorrow of the death of HENRY BURDEN, inventor and ironmaster of this city, a man whose name is known not only throughout our own land, but wherever mechanism is applied to the service of humanity, and one whose enterprise, skill, and ability have built up extensive works in our city, and given to hundreds of people the means of employment and livelihood. A self-made man, his example will long serve as a stimulus to the youth of our country; an employer, putting bread into the mouths of hundreds, he was ever the generous friend of labor, and rewarded it with a liberal hand; an inventor of world-wide fame, his labors were devoted to the good of the human family and the positive elevation of the race; a Christian, he endowed churches free to all, and gave bountifully to all deserving charities; a citizen, he lived without reproach, and dies honored and beloved by this entire community; and it becomes us to place on record our admiration of his life and virtues, and to express our sorrow at his death.

Resolved, That we tender to the stricken family the sympathy of our hearts, and mourn with them over the great bereavement they have sustained — a bereavement that is not alone personal and private in its nature, but public and general in its extent.

Resolved, That the secretary inclose a copy of these minutes to the family, and that the members of the Board be requested to attend the funeral.

The Common Council last evening adopted suitable resolutions to the memory of Mr. BURDEN, and resolved to attend his funeral in a body.

THE FUNERAL.

The funeral will take place at the Woodside Presbyterian Church next Monday at 11 o'clock, A. M. Rev. Dr. Kennedy, formerly pastor of the Second Street Presbyterian Church of this city, but now of Bloomfield, N. J., has signified his acceptance of an invitation to be present and conduct the services. The body will be deposited in the family vault in the Rural Cemetery on the Albany road.

DIED.

BURDEN.— Suddenly, on Thursday, 19th inst., at Woodside, HENRY BURDEN, in the eightieth year of his age.

Friends of the family are respectfully invited to attend the funeral services at the Woodside Presbyterian Church, on Monday, the 23d inst., at 11 A. M., without further notice.— *From Troy Daily Times, Friday Afternoon, January 20, 1871.*

W ~~SUDDEN~~ ~~NO~~ ~~DEATH~~ OF HENRY BURDEN

The announcement of the sudden death of Mr. HENRY BURDEN of the Nail Factory, one of the largest iron workers in the country, was received as startling intelligence this morning and for a time was scarcely credited. Mrs. Proudfit, the daughter of Mr. BURDEN, first discovered that he was dead. She went down to Woodside, the delightful residence of the Burdens this morning, and arrived at the house about 11 o'clock. Entering she inquired if her father was enjoying good health, and receiving an affirmative answer proceeded to his apartment. Mr. HENRY BURDEN's man servant responded, and in answer to Mrs. Proudfit stated that Mr. BURDEN was in very good health and was taking a nap on the sofa. Mrs. Proudfit entered the room and stepping lightly to the sofa stooped over her father and affectionately kissed him. She noticed that he felt very cold and in an instant was astonished by the discovery that her father was dead. The household was immediately summoned in answer to the sad announcement which came like a startling thunderbolt. Mr. BURDEN had been to the breakfast table as usual this morning and had appeared fully as spirited and well feeling as at any recent period.

His death was caused by heart disease, as he had been a sufferer from the complaint. He had made it a custom to retire for rest every morning at about 11 o'clock and did so this morning as usual passing gently and quietly away from the sleep of a mortal to the everlasting repose of death. His servant was in the room all through the morning and did not even know that Mr. BURDEN was dead until the discovery was made by Mrs. Proudfit. Mr. BURDEN leaves two sons, James A. and I. Townsend Burden, who have been associated with him in the iron business under the firm name of H. Burden & Sons, for some time past. He also leaves three daughters, Margaret, wife of E. Proudfit; Helen, the wife of Major-Gen. McDowell; Jessie, wife of son of Gen. Wadsworth of Buffalo. Mrs. Burden died on March 10, 1860, and it is a somewhat

singular circumstance that her death took place about the same time in the morning that Mr. Burden expired. Mr. Wm. F. Burden, one of the sons of Mr. BURDEN, died December 7, 1867. He had been intimately associated with his father in his business, and his death cast a mournful shadow over the entire household, and to the day of his death, Mr. HENRY BURDEN mourned for his departed son. The death of Mr. BURDEN, as we have said, is a startling announcement to our citizens. He was ever esteemed a gentleman of honor, probity, and integrity. He was a member of the Second Presbyterian Church, and in his Christian relations has ever led a pure and blameless life.—*From Troy Press, January 19, 1871.*

www.funeral.com
FUNERAL OF HENRY BURDEN

The funeral of HENRY BURDEN, as heretofore announced, will take place at 11 o'clock Monday morning from the Woodside Presbyterian Church. The services will be conducted by Rev. Dr. Kennedy, formerly pastor of the Second Presbyterian Church. The remains are to be interred in the family vault in the Albany Rural Cemetery, and will probably be very largely attended. The Board of Trade will be largely represented, and the Common Council will attend in a body. Preparations are being made by the operatives of the different works at the Nail Factory. A great part of the attendance will be made up of the numerous personal friends of the deceased both from this city and vicinity and from distant cities. A large number will arrive from New York. Few men who have led such busy lives have been able to grapple to themselves so many warm friends. In all parts of the city we hear anecdotes illustrative of his strong personality and almost resistless will, coupled with, and softened by a kindness of heart and rugged simplicity of manner, that always made even those that had felt themselves wronged his friends. His physiognomy betrayed his character; a strongly outlined, broad, open, even pleasant face, but marked in the upper portion, in the eyes and in the shape of the nose, with an expression of tireless energy, while the strongly compressed lips betokened a confidence in himself that was not to be shaken. If he could begin life over at this time he would in fifty years be again a leader of men. He had in an especially marked degree what is called executive ability. In honoring his memory we honor a great-hearted and a great-headed man, whose fame has really been obscured by his accumulation of wealth. He was looked upon constantly as the capitalist and manufacturer and not as the inventor. Posterity will do him better justice, and indeed it is a question now whether he was not more truly estimated and revered in other cities and in other countries than in the city of his residence. We mean, of course, outside of the circle of his personal friends.—*From Troy Daily Whig, Saturday Morning, January 21, 1871.*

FUNERAL OF THE LATE HENRY BURDEN

The funeral solemnities over the remains of the late HENRY BURDEN were observed this morning in the Woodside Presbyterian Church. At 9 o'clock the men employed in the Burden works visited the late residence of the deceased in a body and took their last look at his face. At 11 o'clock the remains were brought into the church. The interior of the edifice was elegantly draped with emblems of mourning and a monumental tablet to Mrs. Burden was covered with black cloth. The seats in the West transept were occupied by the Board of Trade and a number of distinguished citizens. The East transept was given up to the officers of the church, the foreman in the various departments of Mr. BURDEN's works and the clerks employed in the office of the works. Previous to the commencement of the services a number of floral remembrances, sent by relatives of the deceased who were unable to be present, and wreaths of flowers, the offering of the Woodside Sunday School, were laid upon the coffin. Revs. Messrs. Robinson, Vail, and Halley took part in the services. Rev. Dr. Kennedy preached the sermon. It was a beautiful effort and a most eloquent tribute to the deceased. During its delivery tears came to many eyes. Mr. BURDEN's favorite hymn, "Nearer my God to Thee," and that which had been Mrs. Burden's favorite, "Rock of Ages Cleft for Me," were sung. Among the clergymen present were, Revs. Drs. Coit and Potter, and Rev. Messrs. Chapman, De Witt, Irwin, Noble, and Davies. H. H. Martin, Lansing Pruyn, George M. Tibbits, George B. Warren, John H. Willard, John L. G. Knox, John L. Thompson, and Hannibal Green were the pall bearers. At the conclusion of the church services the remains were placed in a hearse, and were followed to the magnificent and costly vault erected some years since in the Albany Rural Cemetery by Mr. BURDEN by a large concourse, made up of the relatives and friends of the deceased, together with the men employed in the different works in the Sixth Ward. At least 2,000 men were in the funeral procession.—*From Troy Daily Times, Monday Afternoon, January 23, 1871.*

DEATH OF HENRY BURDEN

www.libtool.com.cn

It was the famous Madame de Gasparin who wrote:

“No desert without limits extends before the old man. He walks beside a river whose banks are seen to approach. A diminishing stream separates them each day less and less; and on the opposite bank stand wife and son, with arms outstretched to meet him.”

It was only on the day or two previous to the death of HENRY BURDEN, which occurred at his residence, at Woodside, Thursday forenoon, that many of us saw the deceased walking on our streets, feeble with old age to be sure, but yet apparently in good health, and likely still to survive for many a day. None of us thought he was so near the farther shore, where wife and three sons “stood with arms outstretched to meet him. No one on earth was prepared for the sudden shock that followed the announcement of Mr. BURDEN’S death. On the morning of his demise he had partaken of his breakfast as usual, and had gone up to his room for forenoon nap, as was his usual custom, where, later, his daughter, Mrs. Proudfit, found him cold in the embraces of death!

Mr. BURDEN, of all other men, was the great father of Troy. He had done more than any ten men that ever lived among us to make Troy a great manufacturing city. For forty years his labors had been in a channel that tended directly to the growth of our city. He had established iron mills and manufacturing establishments here that had scarcely superiors if indeed equals in the country. He had given employment to many thousands, and old and young, counted by tens of thousands, that had been his employees at various times during that forty years, were ready at all times to lift up their hands and bless him. He had not an enemy in the world probably at the time of his death, especially as the fierce rivalries of business had all died out and were settled before he retired from active life. HENRY BURDEN was one of the great benefactors of his race. His works will long live after him. In all the broad land there was no better specimen of what honest integrity, industry, perseverance, and persistently directed

www.libtool.com.cn

www.libtool.com.cn

www.libtool.com.cn

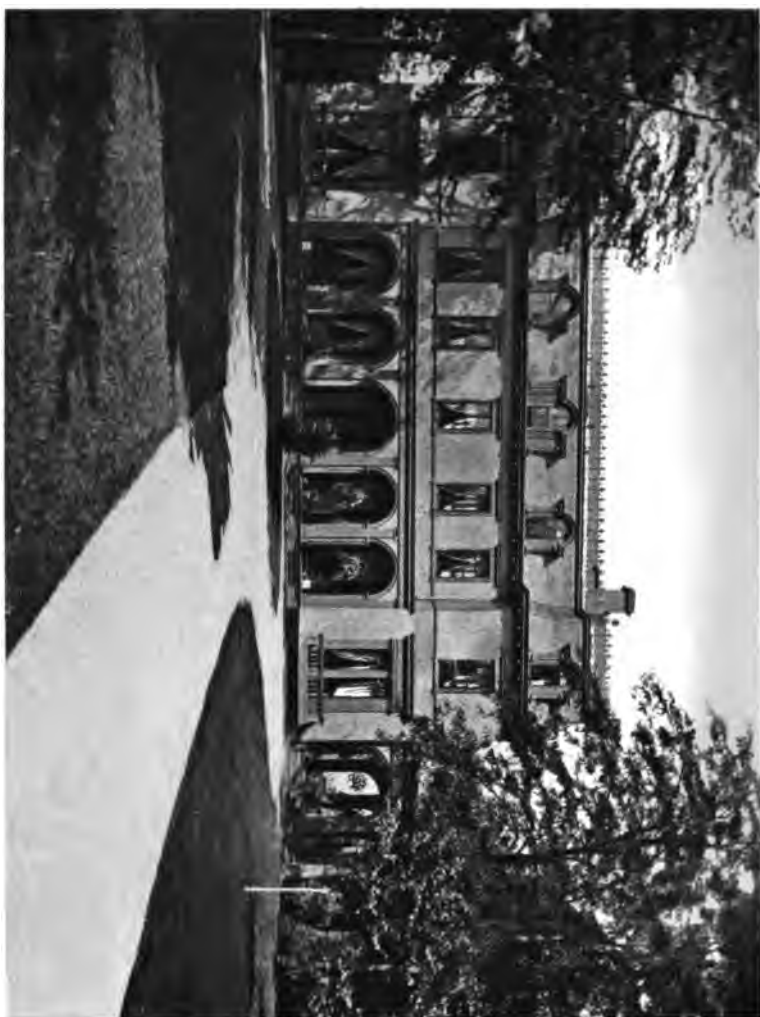

Woodside Residence

www.libtool.com.cn

effort in a given field can accomplish than that afforded by the deceased. There was no better specimen of what a man may make of himself, for himself, and for mankind, from humble beginnings, under the invigorating influences of Republican institutions, than Mr. BURDEN afforded in his own person. Possessing the highest sense of honor, unquestioned integrity, indomitable perseverance, great common sense, and the genius not only of invention but of applying well-known previous discoveries, he was enabled to work out a career of usefulness which scarcely has ever been paralleled on this continent.

We have not the space and room for an extended notice of this great and good man who has passed away in the full ripeness of years, of honor, and of earthly rewards. The simple announcement of the death of HENRY BURDEN will bring its own reflections of saddening and chastening import. We cannot stop to recount his achievements in the fields of invention. All these are likely to be elaborated in less restricted fields than our columns to-day afford. We would render all homage of respect and reverence for the memory of the departed, for he was one of the greatest, the best, the truest, noblest specimens of manhood who ever moved among us! Peace to his ashes!

Nor storied urn, nor animated bust,
Back to its mansion calls the fleeting breath;
Nor honor's voice provoke the silent dust,
Nor flattery soothe the cold, dull ear of death.

Deceased was born in Dunblane, Scotland, April 22, 1791, and came to this country in 1819, and shortly after that time settled in this city, where he has lived ever since. He leaves two sons and three daughters, besides grandchildren. Numerous bodies in this city have passed resolutions of respect for the deceased. His death is regarded as the loss of a great public benefactor, and his funeral, which takes place from Woodside, this (Monday) forenoon is likely to be one of the most heartfelt though unostentatious tributes ever paid to a deceased citizen in this city.—*From The Budget, Monday, January 23, 1871.*

HENRY BURDEN'S FUNERAL

The funeral of the late HENRY BURDEN will take place on Monday morning at eleven o'clock from the Woodside Church, Iron Works. Dr. Kennedy will conduct the services, assisted by several of our city clergymen. The Burden works are, of course, already closed, and the Albany Iron Works as well as the works of J. A. Griswold & Co. will be closed on Monday to enable the workmen to attend the funeral. The Cohoes rolling mill of Morrison & Colwell will also be closed on that day.—
From Troy Daily Whig, Monday Morning, January 23, 1871.

THE LATE HENRY BURDEN

We, the operatives of the Burden Iron Works, assembled for the purpose of giving some expression to the great sorrow with which it has pleased God to afflict our hearts by the death of HENRY BURDEN, do declare:

That, bowing submissively to the decree of the Almighty, we sincerely mourn the loss of our revered and beloved employer — whose great abilities won our admiration — whose high character commanded our respect, and whose countless acts of kindness endeared him to each and all of us. We shall sadly miss his noble form and venerable countenance in our daily walks; but the remembrance of his deeds and goodness will linger while memory endures. Especially shall we love to recall the interest he took in our affairs and the high regard which in his prosperity he always manifested for the workingman, experiencing his greatest pleasure when his hospitality assembled the workmen — his "large family" around him.

While we thus mourn the loss of one who was dear to us, we join with the entire community and the world at large in deploring the death of one who was, in the truest sense, a benefactor of mankind — a man of wonderful mechanical genius,

who enriched the world with inventions of universal importance — one who founded vast industrial works — who furnished the means of support for thousands of persons — and who, while laboring for the material advancement of his fellow men, manifested also his devotion to Christianity by a generous support of all benevolent objects, and particularly by the erection of a beautiful edifice for religious worship. His life is a bright example and an encouragement to all workingmen, an evidence that honest, persevering industry can achieve the highest success without the aid of fortune.

We tender to the afflicted family our heartfelt sympathy in their sad bereavement. We feel that no words of ours can lessen their grief, but it is to us a concolatory reflection that the last moments of our beloved benefactor were calm and free from suffering, and that after long years of usefulness, crowned with honors that are granted but to few, his life had so gentle and so peaceful a close.

In token of our respect we shall attend the funeral in a body.

GEORGE JAMME, *Chairman.*

THOMAS B. COOK, *Secretary.*

The following resolutions were adopted by the congregation of the Woodside Presbyterian Church, Friday evening:

WHEREAS, It has pleased our Heavenly Father to call away suddenly from our midst Mr. HENRY BURDEN, an aged and venerable member of this church, and

WHEREAS, Our departed friend, by his many acts of benevolence, but more especially by his crowning gift of the substantial edifice in which we are now assembled, and where we are free to worship God according to our consciences, has placed this congregation under a lasting debt of gratitude to his memory; therefore, be it

Resolved, That while we feel keenly the loss of our kind-hearted patron and generous benefactor, we rejoice that amid

all his extensive business and multiplied cares the great concerns of religion were not forgotten, and that his love for her ordinances was so distinctly manifested; and we hereby express our gratitude to God, who, in His kind providence, permitted him before the close of his eventful life, to carry out to completion the wish so long cherished by himself and his much esteemed and departed wife, viz.: that of erecting a Presbyterian church for the benefit of this community.

Resolved, That we will ever strive to show our respect for the Christian character of Mr. BURDEN and our appreciation of his beneficence by endeavoring to keep in successful operation the enterprise so auspiciously begun.

Resolved, That we extend our warmest sympathy to the sorrowing relatives and friends, and affectionately commend them to their father's God and their God, with the prayer that He may sustain and comfort them in their hour of trial; and would convey to them the assurance that the name of HENRY BURDEN will long continue to be very dear to this people; and would further express our heartfelt belief that generations yet unborn will have abundant reason to bless the memory of him whose heart the Lord touched with a desire to build a house where His name might be worshipped.

Resolved, That a copy of these resolutions be sent to the family of the deceased and that copies be sent to the city papers.

RICHARD DAVIDSON, *Chairman.*

J. WATSON, *Secretary.*

At a meeting of Thomas' Cornet Band, held at their band room Saturday evening, January 21, 1871, the following preamble and resolutions were unanimously adopted:

WHEREAS, This community has been suddenly deprived of one of its estimable members and most valuable citizens in the death of HENRY BURDEN; therefore, be it

Resolved, That in this sudden and sad dispensation of a mysterious Providence we have been deprived of a worthy and

www.libtool.com.cn

www.libtool.com.cn

www.libtool.com.cn



Woodside Church

www.libtool.com.cn

beloved friend, whose many virtues, goodness of heart, and genial character endeared him by more than ordinary ties to all of those to whom he is known.

Resolved, That in his death society has lost a most valued citizen, an estimable and worthy friend; the church a warm and devoted Christian; and we, as a band, a worthy benefactor. As a man, he was pure, generous, and faithful; as a Christian, humble, zealous, and exemplary; as a friend, always true, frank, and kind.

Resolved, That while many virtues and good qualities endear his memory to us, and should serve as bright examples for our imitation, we are all reminded by his departure "that in the midst of life we are in death."

Resolved, That we tender to the relatives and friends of our deceased friend the assurance of our heartfelt sympathy and sorrow in our common loss, and while we deplore the dispensation which has removed from our midst a warm-hearted friend, we sincerely believe and trust that he has found "that House not made with hands, eternal in the Heavens."

Resolved, That we will attend his funeral in a body, and wear the usual badge of mourning.

Resolved, That the foregoing resolutions be published, and a copy furnished to the family of the deceased.

H. R. THOMAS, *President.*

LORENZO BRAMAN, *Secretary.*

A TRIBUTE TO THE MEMORY OF THE LATE HENRY BURDEN

At the evening service Sunday, at the Fifth Street Presbyterian Church, the pastor, Rev. William Irvin, paid an eloquent tribute to the character of the late HENRY BURDEN.

The subject of the discourse was "Death Under Figure of a Journey." He said Mr. BURDEN had belonged successively to the First, Second, Second Street and Woodside Presbyterian churches, and now God has called him to the Church triumphant in Heaven. It was a suggestive fact that Mr. BURDEN'S last hour in the sanctuary was spent with this congregation last Sabbath evening, with the church with whom just forty-two years ago, he confessed Christ. The reverend speaker dwelt upon the extensive usefulness, the high example, and the large liberality of the deceased, as worthy of all imitation. His remarks were listened to with profound attention.

To show how Mr. BURDEN was appreciated abroad we have only to copy the following obituary of him from among many in our exchanges, which we find in the "Utica Herald:"

"Troy is mourning for one of her best citizens. The sorrow will spread from that city to every hamlet in a country that is not slow to acknowledge its indebtedness to individuals. Mr. BURDEN belongs in the front rank of American inventors. His name is fit company for the names of Fulton and Morse. A thousand workshops, out of whose grimy walls come the utensils that work the nation's wealth, pay daily and unwitting tribute to HENRY BURDEN. He invented the first American cultivator. He first discovered a way to make horse shoes and wrot spikes by machinery. He invented the self-acting machine for rolling puddle iron into bars. He built the first boat on the celebrated 'cigar' pattern. The history of his inventions is one of the most important leaves from the history of American industry. His private life was irreproachable. Charity never looked to him in vain.

"The fortune that his industry and ingenuity accumulated was never niggardly in good works. His fellow townsmen loved the man they respected. He was a Scotchman by birth and came to this country in 1819. We cannot do too much honor to the memory of the man who did so much, and so modestly, for us." —
Troy Times, Jan. 24, 1871.

www.libtool.com.cn

THE LATE HENRY BURDEN

**FUNERAL SERMON PREACHED BY REV. DR. KENNEDY
AT WOODSIDE CHURCH, JAN. 28, 1871**

www.libtool.com.cn

HENRY BURDEN

www.libtool.com.cn

It is with great difficulty, friends, I have consented to conduct the services of this occasion. My long and intimate fellowship with this bereaved family, and the more than common relations of friendship subsisting between us, make me feel as if it were more fitting that I should take my place with them in silence and sorrow. The recollection of by-gone scenes of blended joy and sadness in which we have mingled,— the memory of loved ones who so kindly smiled upon me in their days of health and activity ; to whom in sickness I was permitted to offer counsel and consolation, and over whose shrouded forms I have wept in the fulness of my grief, comes up to my mind at this moment with peculiar vividness, and almost disqualifies me for the duties of the hour. To the memory of the beloved mother and the noble son, to whom not long since I rendered the last of earthly services, is now added that of the venerable father, of whose sincere friendship and affection I have ever enjoyed an unfailing expression. As I stand here, only because I cannot find it in my heart to decline any service which the living desire me to render on behalf of their dead.

Most deeply do I regret that I have not had the opportunity to prepare to meet the just demands of the occasion. I can only offer the few disconnected thoughts I have at command as a tribute of affection, not doubting that some other hand will, in due time, undertake an appropriate record of the character and achievements of our departed friend.

The event of death, come when it may, and invested in whatever garb, is always an important occurrence, and invites to serious and profitable meditation. It brings before us without figure and without romance, in simple and stern reality, the great fact of human mortality. And notwithstanding the frequency of our admonitions, there is perhaps no one truth which is more difficult to impress upon our minds, with the force of a practical conviction than this. Amid scenes of healthful activity, engaged in the varied pursuits of life, how seemingly difficult to realize,

that within ourselves are found all the elements of that mighty change which departed friends and loved ones have undergone. And often as we stand by the couch of the dying, or look upon the features of the dead, how prone are we to *forget* that what we have contemplated is but a simple and truthful illustration of what must speedily take place in reference to ourselves. Earnestly, therefore, should we strive to admit the conviction and suffer it to make salutary impressions upon us. It cannot be wise to close our eyes against an event so inevitable in its occurrence. "It is appointed unto all men once to die." There is no exception to this law — there is no exemption from this decree. Let us seek then to cultivate a sober acquaintance with this truth, and strive to profit by the important lessons which it inculcates.

Let us remember, too, that the period when this great event is to transpire cannot be far distant to any of us. Grant to each of us the full measure of time allotted to human life: let us be assured of the extent of three score and ten years; nay, let our pilgrimage be lengthened out to the four score years enjoyed by the venerable man who lies before us, and still how brief the journey from the cradle to the grave! We have contemplated the morning mist rising from the bosom of yonder river; we followed its fleecy form lifting against the brow of the distant mountain, anon it disappeared, and was not. "Our life is a vapor which appeareth for a little, and then vanishes away." We have looked upon the delicate flower as it put forth its beautiful blossoms and unfolded its tender leaves in early spring; we have admired and loved it, but suddenly it lay withered and dead, at our feet. "Man's days are as a flower of the field; it flourisheth but a moment, for the wind passeth over it and it is gone." These figures are not only beautiful, my friends, but they are truthful and impressive, and admonish us that whatsoever our hand findeth to do we should do quickly.

And what, dear friends, as moral and responsible beings, have we to do? Does our exit from this world terminate our being? Is there no hereafter? Does the soul lie with the body? It is not so. While we are mortal, we are at the same time immortal. To the mysterious principle within us which thinks and reasons

and feels, God has decreed a deathless existence. It sustains moral relations to the government of the Most High, which no changes affecting the body can ever alter. And the condition of its existence hereafter is made to depend upon its choice, its purposes, its conduct here. During the period of our brief sojourn here — during the short time in which the vapor rises and vanishes, and the flower blooms and perishes, we are to prepare for a blessedness that shall never end, and failing to do so, shall enter upon a destiny of misery equally enduring! And time when viewed in this connection, how short does it appear! How ought we then to prize its passing moments; and how importunate should be the prayer, "So teach us to number our days that we may apply our hearts unto wisdom."

The event which has brought us to this sanctuary this morning is not, in some important respects, a common one. It is indeed true that death, in whatever form it comes, or whatever age or standing may be its victim, is marked by certain invariable features. It is ever and in all circumstances accompanied by the rupture of tender ties, and brings sorrow to loving hearts. But how often does it take place under circumstances in which the mere temporal features connected with it excite but little sympathy, and make a correspondingly slight impression upon the community. How many die whose lives have been of no value to society, who have done nothing for the benefit of their kind, and for whose memory there can be cherished neither reverence nor respect. Having failed to improve the powers which God had given them, they have had but little beyond a mere animal existence, and their loss is scarcely greater than that of the brutes that perish. How many, by a positive perversion of their gifts, make their lives an injury to the world. And the world cannot be blamed if it mourn not when they are dead!

How different the features which mark the departure of that man who can be numbered among the benefactors of mankind, who has lived under the sense of a just responsibility to Him who made him in His own image; who has sincerely sought to honor the author of his physical and intellectual endowments by a voluntary consecration of his gifts to the service of God and the good

of his fellow men. When such a man dies the event is commensurate in its effects with the character he sustained and the good he accomplished. The influence of such a death is felt beyond the immediate family, beyond the surrounding neighborhood, it reaches the community at large, extending wherever the individual has been instrumental of good to his fellow men. Such a man's death, in one aspect of it, can scarcely be called death; he lives in the noble character he possessed, he lives in his works of beneficence, and will live so long as they shall continue to bless the world. He thus secures a sort of earthly immortality. Or if we must say he dies, it is because his work in this world is completed, and he is transferred to a higher sphere.

It is a pleasing thought that those achievements in science and art, made through human exertion, and which have proved really useful, have never been forgotten, and never will be forgotten. Every discovery and every invention which experiment has proved to be conducive to human welfare, is at once appropriated, and made permanent in the storehouse of the world's accumulated wisdom. It immediately works itself into the texture and framework of human society, and is never cast off. It becomes blended with the great elements of human thought and action, and lives on, acquiring increasing interest and value while human interest shall be dependent upon it, and human happiness shall be promoted by it. Such is the tribute of honor which Providence has awarded, even in this world, to the author of any discovery or invention which contributes to the benefit of the race.

This consideration serves to give special interest to the name and the memory of the man whose mortal part we are about to consign to the house of silence.

A man whom it is impossible to contemplate without emotions of respect and reverence. Favored by nature with a physical organism symmetrical in proportions, commanding in form and stature, developed by exercise, weakened by no improper indulgence, vigor and activity of mind and body were impressed upon every feature, and reflected in every movement. Wherever seen, his appearance attracted observation as a specimen of noble and complete manhood.

With intellectual powers of a high order, a benignant Providence endowed him with an inventive faculty so fertile in its resources, and so varied in its practical workings, as to give him a distinguished place among those whose genius has proved a blessing to the race. In the great department of mechanical invention, by which the elements of nature are combined, arranged and adjusted so as to produce new and useful results, the name of HENRY BURDEN will be associated with those of Cartwright and Whitney, Fulton and Morse, the products of whose genius are now found in every quarter of the civilized world.

With a modesty and simplicity of character seldom dissociated from true greatness, he was at the same time singularly *self-reliant*. In him this quality bore no relation to the presumption which springs from vanity, nor the confidence engendered by conceit. Never was man more free from such a weakness than he. It was that noble, manly self-reliance which had its source in the conscious possession of powers adequate to meet the occurring emergencies of his position. He was one who could say, "I will dispense with such a piece of machinery" — which the world had for ages considered indispensable — "and supply its place with a better," and he did it! He could say, "I will produce a single mechanical agent that will do the work of scores of men," and he did it! So well did he comprehend the extent and limits of his resources, that he undertook only what he foresaw could be accomplished, and wasted neither time nor effort in hopeless experiment.

In Mr. BURDEN was illustrated the cardinal truth, generally so little appreciated, that true greatness is attained by the individual man, only through the assiduous culture and development of the faculties God has given him. In vain are gifts bestowed unless they are cultivated. The talent buried in a napkin will never become productive. The plant that has neither soil nor dew will bring forth no fruit. And the best native abilities unexercised and undirected to noble ends, being thus necessarily perverted, degrade the possessor and dis-

honor their giver. Here we find one secret of the power Mr. BURDEN has wielded. Possessing naturally a strong will, intense energy and unflagging perseverance, he was eminently qualified to prosecute the high aims which he had formed in early life. These elements of character became the source and the pledge of the success which he ultimately achieved. With faculties under control, and energies concentrated, he overlooked all side issues, kept his eye steadily fixed on his chosen life-work, disdaining everything that might disturb the balance of his powers, or weaken the vigor of his resolution. Determined to live to some purpose in the world, and leave a salutary impression upon the age, he laid hold of the agencies which Providence had placed within his reach, moulded them to his will and made them tributary to the accomplishment of his designs.

AND now, what were his designs? What was the end he sought to accomplish in life? I am certain that it was not wealth, that it was not fame. And though an adequate measure of these fell to his lot, yet I am fully convinced—and the conviction is based upon an intimate acquaintance with the springs that moved his inner life—that considerations of material acquisition or personal aggrandizement had little or no influence upon his mind. His motives were purer, his aims were higher. He was eminently an unselfish man. His intense mental activity partook in no sense of the feverish restlessness of ambition. The cravings of his mind savored in no measure of the graspings of sordid avarice. On the contrary, his intellect was constantly teeming with projects and his heart yearning over schemes by which new developments and practical applications of unappropriated resources of nature might be made to lighten human toil, multiply human comforts, accelerate human progress and promote human happiness. His grand aim was to do good to the world; and in the success of the effort he deserves the esteem, and receives the honor due to a public benefactor.

But with his inventive genius, intense energy and elevated

purpose, was associated a *high moral character*. In all his dealings with his fellow men he was rigidly honest. He seems to have had an intense innate repugnance to everything like intrigue or double dealing. When approached in the business relations of life, every one received the impression of having to do with a fair-minded, frank, true man,—a man of whom no suspicion could be entertained of sinister designs, or a concealed purpose to overreach or defraud. Upright himself, he was apt to take for granted the uprightness of others. And though this assumption exposed him to the intrigues of men of less conscience and more versed in the arts of deception, he still maintained his rectitude of character to the last, never consenting to meet fraud with fraud, or to return evil for evil; thus realizing to us the ideal of the significant moral apothegm, "An honest man, the noblest work of God."

And here it is natural, as well as truthful, to add that *Mr. Burden was influenced by religious principle*.

Educated in his native land under a system which recognized the authority of the Bible and the catechism as a source of salutary instruction and restraint, he had early acquired a deep reverence for the truths of revealed Christianity. In mature manhood he made public profession of his faith in the humbling, yet exalting doctrines of the cross, and sought to conform his life to the obligations he had assumed. Though possessed of an intellect capable of grasping abstruse points in philosophy and theology, he had no taste for profitless speculations. He preferred to receive the great doctrines of the Bible, as there set forth in their massive proportions, without any wish to contract their dimensions, or weaken their authority. Hence profound reverence for the word of God and an unquestioning reception of its cardinal truths marked his religious experience.

The development of Christian character varies in different persons, as it is modified by natural temperament and providential circumstances. In some the growth of one class of the Christian virtues is more rapid because of conditions more favorable to their development, while others are more gradual

in their increase and reach their maturity at later periods of life. Owing to peculiar circumstances in Mr. BURDEN's business relations, an ample scope was furnished him for the exercise of a spirit of forgiveness of injuries, and a disposition to become reconciled to such as might have done him wrong. And here, I believe, he gave a clear exhibition of this Christian grace. In all my intercourse with him, and while often seeking to try his character by this test, I always found him ready to refer supposed encroachments upon his rights to the frailties of our fallen nature, and to evince a cheerful willingness to become reconciled to an offending brother. He thus seemed to have imbibed the sentiment and acted out the spirit of the petition, "Forgive us our debts as we forgive our debtors." Though decided and outspoken in his denunciation of supposed wrong, he seemed willing to make sacrifices for the good of the wrongdoer, and for peace sake, in obedience to the Divine injunction — "Love thy neighbor as thyself." In repeated conversations with him on other points of Christian experience, especially after he had been called to part with the companion of his youth, there was readily discovered a growing impressibility to religious interests, and an increasing tenderness in regard to the claims of the cross. He seemed to cherish a grateful appreciation of the hallowing influence which the devoted Christian life of his wife had silently exerted upon him, and to form the resolution of a more entire consecration to the service of her Father and his Father, of her God and his God. And as years passed on and successive bereavements came upon him, his trials seemed to give increasing mellowness to his spirit, indicating a growing meetness for the activities and immunities of a higher and better life. Affected by a disease which he well knew must speedily and suddenly loosen the silver cord, he contemplated the event with cheerful composure, and with increasing reliance upon the blood of the Redeemer. He felt at length that life's work was done and that he was ready to depart. When asked some little time since why he ceased to manifest his usual interest in

secular reading, he quietly answered that his reading now had exclusive reference to the concerns of the soul. A week ago last evening, when asked what he desired to have sung in the devotions of the family, he referred to what he called his favorite hymn, "Nearer my God to Thee, nearer to Thee." And we cannot but believe that the aspiration breathed in that sacred song has been realized by him in the vision of God and the Lamb. In the vacant space on yonder tablet his name will now be recorded beside that of her who had gone before, to remain a beautiful symbol of the reunion of loving hearts in the better land, where parting shall be forever unknown.

Brethren and friends: It is in my heart to say much more than I have been permitted to say. I am oppressed by the knowledge that I have failed to meet the demands of the occasion. With a more ample delineation of the character of the deceased, I had designed to speak to this church, to the members of this thriving community, to the different civic departments of the city of Troy, to persons present from other cities, to the aged, the middle aged and the young, as I felt that valuable lessons of instruction and encouragement, drawn from the life and character of our departed friend, could be addressed to all. But circumstances which I could not control have set a limit to my imperfect address. Permit me only to say to one and all, improve the talents which a benignant Providence has committed to your charge. Set your mark high; act well your part in the great drama of life; strive to do good in the varied stations in which Providence has placed you; and then, whether rich or poor, elevated or depressed, relying upon the grace of God in Christ, you will at length receive the high plaudit, more valuable to you than the ovations of the universe beside, "Well done, good and faithful servant, enter thou into the joy of thy Lord." — *Troy Daily Times, Tuesday afternoon, January 24, 1871.*

www.libtool.com.cn

www.libtool.com.cn



www.libtool.com.cn

www.libtool.com.cn



Henry Burden, Inventive Age.

www.libtool.com.cn

www.libtool.com.cn

THE GREAT EXHIBITION

MACHINERY HALL

**MORE INDIVIDUAL EXHIBITS OF MARKED INTEREST —
THE BURDEN HORSESHOE MACHINE — THE ME-
MORIALS OF A GREAT INVENTOR**

www.libtool.com.cn

HENRY BURDEN

www.libtool.com.cn

PHILADELPHIA, *Saturday, June 3, 1876.*

There must naturally be a line of demarcation somewhere between the ingenuity of wisdom and the ingenuity of folly. Exactly where this line is drawn I do not know, nor do I suppose that it can well be defined; but I came across an example to-day of consummate folly, with regard to the classification of a certain exhibit, which renders, in its case, any discussion of the line of demarcation utterly unnecessary. By some extraordinary piece of misunderstanding, oversight, ignorance, folly, or whatever any one may choose to call it, one of the most interesting pieces of machinery has been relegated to that section of Agricultural Hall in which Mr. Seth Green's fish-tanks occupy a very prominent place, but are, in my humble opinion, not at all calculated to give the visiting public any impression of the great work which Mr. Green is doing. I speak of the beautiful working model exhibited by the Burdens, of Troy, of their patent for making horseshoes by machinery. We have done wonders during the last hundred years. We are almost startled ourselves when we look back and call the roll of the many marvelous inventions which have been born even in our own lifetime; and we are all only too willing to acknowledge that we know not what a day may bring forth in the way of mechanical invention and scientific discovery. But surely, even Mr. Seth Green, in the wildest flights of his imagination (and he may be the soberest-minded individual possible, for all I know to the contrary), could never have contemplated the manufacture of fish, like horseshoes, by machinery; nor do I anticipate that, in course of time, the denizens of the piscatorial world will be broken into marine beasts of burden for drawing flotillas of merchantmen or ocean-going steamers, like so many express sea trains, between New York and Liverpool. Granted that the whale and other marine monsters could be impressed into such a service, would it not be

better that they should be shod with some improvement on the propeller which nature has given to them, rather than with a patent Burden horseshoe? But the wiseacre who has had charge of all these matters — happily I do not know who it is — thinks differently, and Mr. BURDEN's wonderful machine wastes its sweetness on the desert air, and is passed by on the other side of the way by the Levites of bucolic tastes and interests. Why, he might as well have consigned that \$100,000 diamond necklace of Mr. Tiffany's, which is causing all the ladies' hearts to throb, and which will certainly deplete somebody's banker's balance before the Exhibition closes, or one of Mr. Doulton's beautiful pieces of faience, or Elkington's glorious Helicon vase to the boot and shoe department! It seems almost incredible, but it is a fact, that when the Burdens remonstrated against their machine being placed in Agricultural Hall, in direct opposition to their application for space for its exhibition in Machinery Hall, they were treated with no consideration whatever; and this in the case of a firm who stand among the foremost ironmasters of the world! There is not a truesouled mechanic who will not resent this petty slight on the memory of the late HENRY BURDEN, the inventor of the machine in question, and a thoroughly representative man of his day. HENRY BURDEN not only invented this horseshoe machine, but he invented the famous "Burden Squeezer," through which all the iron made into two-thirds of the rails laid down in Great Britain passed for many years; he produced the first railroad or any other spike ever made by machinery; he invented the American system of berths on steamboat decks; he built the first cigar-boat, afterward one of the pet ideas of Mr. Winans, and he organized in Glasgow, in 1850, the famous Atlantic ferry, for building and running a line of steamers to this country of greater length in proportion to beam, and of greater tonnage, than then in vogue, which were to cross the ocean in seven days. His designs were almost the essential counterpart in build, in these respects, of the vessels which the great ocean-going steamship lines now regard as the best mod-

els. But HENRY BURDEN was, in this regard, ahead of the times in which he lived. The Glasgow people were afraid of the lines of his models; they returned to the old ideas, and BURDEN, throwing the thing up in disgust, returned to this country and established one of the very largest iron manufacturing businesses in the United States. It was only a few months ago that the Royal Historical Society of Great Britain applied to Mr. BURDEN's family for all the information they could furnish with regard to his connection with steamship building, and his many valuable inventions, for the purpose of making due record of them for the benefit of the whole British nation. It should be the delight of this country, in this Centennial anniversary year, in this exhibition of the Nation's progress and advanced civilization, to do honor to the memory of such a man as HENRY BURDEN was. But some one, invested with a little brief authority, has thought otherwise, and one of his greatest inventions is unknown, so far as its representative in the Centennial Exhibition is concerned.

I do not propose to let this perfect piece of machinery remain hidden away, and, in case it be too late to have it installed in its proper position in Machinery Hall, which ought surely not to be the case, I will tell the readers of "The New York Times" all about it and its wonderful doings. In the first place the ordinary working machine is neither large nor complicated. On the contrary its simplicity is one of its leading features. The two things about it which first strike the eye are some wheels and a long reheating furnace adjoining them, the latter looking very much like a horizontally-built chimney. Bars of iron forty feet in length are brought hot from the rolling mill and are placed in the reheating furnace for the purpose of annealing the iron. As soon as this process is completed, the bar of iron is passed into the machine through two rollers, which act as automatic feeders, the rollers being kept in constant pressure on the bar by an attachment to the cutting lever, which, working on a cam, cuts off the bar just the necessary length of iron to make one horseshoe. At the moment of

cutting off, the bending tongue catches the piece cut off and carries it into the first die, which gives the shape and form to the shoe. It then passes on to another roll and shaft, called the creasing shaft, on which is a die to which the creasers are attached, and by means of which the creasing of the shoe is produced, while, at the same time, the holes for the nails are pierced. Here is then a finished shoe for horse or mule, which has only to be heated and fitted by the local blacksmith before being used. One great advantage of this machine is that any shoe of any shape, size, or pattern can be made upon it with the utmost ease. A buyer may send a shoe of peculiar pattern, and one which would puzzle a blacksmith to make, with a secret private mark upon it, accompanied by an order. His order, no matter if it amounts to 1,000 tons, will be delivered to him exactly to his pattern; any possible variation in a single shoe in the whole consignment requiring a microscope to discover it. It is done in this way: A plaster cast of the pattern shoe is carefully taken, and this plaster cast is used instead of the ordinary wooden pattern for making the sand mold in which the iron die is to be cast. By this means the cast-iron die, when placed in position in the machine, possesses the absolute counterpart of the original pattern, even including the unknown secret private mark. In precisely the same way the creasing can be made of any desired form or shape, and the nail holes can be as easily made of any desired angle. As soon as the horseshoe comes from the second die (plenty of water is always dripping from the machine), it is carried off to the storehouse on an endless chain, and by the time it arrives there is comparatively cool. The storehouse is a large circular building, composed of radiating bins, with just open space enough in the center to allow a horse and wagon to turn around. Every bin has its own size and shape of shoe, the bins holding in the aggregate no less than 7,000 tons of finished shoes. The plant at present in use turns out about 600 tons of horseshoes per week; but the Burdens are putting in new plant which will just double the capacity of their pro-

duction, and will shortly have another storehouse complete, which will double their storage capacity. Those who are familiar with the length of time it takes a blacksmith to make a horseshoe by hand will appreciate the capabilities of the Burden horseshoe machine, when I say that it turns out ordinarily from sixty to seventy shoes a minute, and can turn out as many as 100 a minute. These horseshoes are sold largely in every State of the Union at a mere fractional advance on the price of the best horseshoe iron, and, indeed, in the eastern States they are sold at the same price. They wear better and longer than hand-made shoes, from the simple fact that the iron from which they are made is better prepared than the ordinary best horseshoe iron. In fact, horseshoes made by the Burden machinery are about as superior to hand-made horseshoes as are pins or needles made by machinery to those made by hand. During the war the horses and mules of the government were all shod with these shoes, and the quartermaster used almost invariably to report that when the rebels made a raid on their stores, the first things they went for were boots and shoes, clothing, and Burden horseshoes.— *New York Times*.

www.libtool.com.cn

TROY'S TRIUMPHS

**THE IMMENSE IRON MILLS OF H. BURDEN & SONS —
A MILE OF MANUFACTURING BUILDINGS — THE
WORLD'S GREAT WATER-WHEEL — HORSESHOES
FOR MORE THAN TWELVE MILLIONS OF HORSES —
ACRES OF WONDERFUL MACHINERY — STARTLING
STATISTICS**

www.libtool.com.cn

The ancient Greeks and Romans were accustomed to ascribe their successes to the agency of the gods. Their knowledge of working in metals was imparted them, it is said, by Vulcan, the deified instructor of men in metallurgic arts. Marvelous stories are related of his giving Alcinoüs, king of the Phæacians, gold and silver dogs which guarded the royal palace, of his making the golden maidens who served him, and whom he endowed with reason and speech, and of his presenting to Minos, king of Crete, the brazen man, Talus, who each day thrice compassed the island to protect it from the invasion of strangers. Fire, the great agent employed in the reduction and working of metals, they said, was withheld, at first, from man through the kindness of the gods, but that Prometheus, another fabled benefactor of man, stole it from Heaven, in a hollow staff, and brought it to earth.

Beliefs such as these, for centuries, were grafted on the minds of men. Then came a disturbing period of transition, in which men began patiently to investigate the secret laws of nature and to solve and intelligently explain the manifold complexities of the elementary substances. Having learned, in part, the peculiar chemical combinations of minerals, an advanced step was then made in applying this derived knowledge by certain novel processes to uses beneficial to man. Startling facts were discovered in this new field of applied chemistry and mechanics more astounding than the fabled contrivances of Vulcan; passive elements were transformed into active agents whose energetic forces were made obedient servants of the directive will of man; and splendid pyrotechnic spectacles were looked upon with inquisitive eyes and their tell-tale flames interrogated to solve the intricate problems of their chemical colorings.

In those vast museums of science and art, for such are the various buildings of the iron and steel manufacturing companies in the southern part of this city, are to be seen unsuspected wonders of elemental combination and operative machinery. As one wanders through these extensive structures covering many acres

of ground, and views the flaming furnaces and fiery crucibles, the immense rolls and ponderous hammers, the great boilers and powerful engines, the toiling groups of brawny men and the ubiquitous and observant superintendents, he is almost persuaded to believe that he is looking on a scene of magical enchantment rather than upon a real spectacle of organized labor and curious mechanisms. A thousand questions arise in his mind in regard to the peculiar circumstances which gave rise to this grand engineering,— who were the men that contrived these ingeniously constructed machines with their wonderful effective action,— and what must be the quality and the quantity of the products of these great manufactories annually.

THE OLD MILLS ON THE WYNANTSKILL.

To comprehend clearly the growth of the several branches of this local industry, it would be well, just here, to advert to the early history of the manufacture of iron in this city. It should be known that the waters of the Wynantskill have, for more than 200 years, been utilized as motive power by persons living along its declivitous banks. Its limpid current was first made to turn the rude water-wheel of a saw-mill erected by the early Dutch settlers. In 1674 this mill was purchased by Wynant Gerritse van der Poel, from whom the creek received its name. More than a century afterward, in 1789, David Defreest, or De Forest as he was then called, built a fulling-mill, where now is the water-mill of the Albany and Rensselaer Iron and Steel Company, a short distance east of the bridge, near the terminus of the horse railroad. A flour mill was erected in 1796 by Thomas L. Witbeck, on the site of the Bessemer Steel Works. By an agreement with David Defreest, he was permitted a water privilege by building from the Wynantskill to his mill a "trunk made of joice boards and plank," and to "raise the fulling-mill dam and flume belonging to the said David Defreest." In 1807, John Brinkerhoff removed the fulling-mill and erected in its place a nail factory. John Converse and several copartners, in 1809, obtained two water-power leases eastwardly of the property occupied by John

Brinkerhoff, and erected a rolling and slitting-mill at the upper fall. This establishment was in 1813 further enlarged, and became the property of the Troy Iron and Nail Factory Company, which was represented in the persons of Ruggles Whiting, John Converse, Nathaniel Adams, E. F. Backus, and Henry W. Delevan. As stated in the act of incorporation, it was the purpose of this company to manufacture bar iron, steel, nail-rods, hoop-iron, iron-mongery, and sheet copper, and forming and making all kinds of machinery, tools, and implements. The company had a capital of \$96,000, the stock being divided into sixteen shares of \$6,000. Besides manufacturing an excellent quality of cut nails, this company also made iron shovels and spades in large quantities. This mill, which was under the superintendence of John Converse, had only a pair of rolls in operation for rolling out and slitting the imported iron into nail and spike-rods, and a few machines for cutting nails. The revolution of the rolls must have been necessarily slow, for the motion given them was by a pair of water wheels, one at each end, connected to them as if upon a single shaft. The ground still eastward of this and now covered by H. BURDEN & SONS' reservoir dam, was in 1812 leased by Smith Cogswell, for the erection of a gun factory.

THE VALUABLE INVENTIONS OF HENRY BURDEN.

The coming of HENRY BURDEN from Scotland, where he had been educated in engineering and drawing, to the United States, in 1819,— at the suggestion of our Minister at London, who gave him letters of introduction to the Hon. Thos. H. Benton, the Hon. John C. Calhoun, and the Hon. Stephen Van Rensselaer,— was an event of no little importance to the manufacturing interests of this country. To this distinguished inventor one of Troy's leading industries owes its successful development and distributed benefits. It was in this city that his persistent thoughts framed the peculiar imagery of those wonderful contrivances which have rendered his name famous and their productions notable throughout the United States and in England. It was here that his directive energies and executive ability mastered the numberless

difficulties which beset this particular industry in the early years of its incipiency, and gave it a prominent position among the iron manufactories on this continent. It was not a desire of making money by the sale of patent rights or of royalties that HENRY BURDEN's mind brooded for years over plans and methods for producing by machinery those triumphs of his skillful devising, but to furnish his mills with economical and useful contrivances by which he could increase the facilities of production and lessen the expense of manufacturing the articles made here, for many years, by hand. When in 1822 he came from Albany, where he had been engaged, at the suggestion of Stephen Van Rensselaer, in making agricultural implements, to Troy, and took the superintendence of the Troy Iron and Nail Factory, not only was the machinery in the little wooden mill of the company imperfect in its action, but the water power of the Wynantskill was insufficient to supply constantly the wants of the manufactory. He at once applied his technical skill in discovering better mechanical methods of making nails and the means of increasing the supply of water in the Wynantskill.

THE SPIKE MACHINES.

In 1820, before coming to Troy, he invented the first cultivator used in the United States. The first problem which taxed his inventive mind, after his connection with the Troy Iron and Nail Factory, was the construction of a machine for making spikes. This idea was suggested to him by his daily inspection of workmen, in the mill, slitting spike-rods, which were made into bundles weighing fifty-six pounds and afterward forged into the required size by hand. In a very short time his studious mind devised a machine for manufacturing wrought nails or spikes, for which he secured a patent May 26, 1825. Like all inventors, he encountered considerable opposition at first in introducing his machine-made spikes into popular favor. There was a prejudice among shipbuilders against them that was not easily changed, for it was their belief that they were almost worthless when compared with those made by hand. For a new and useful improve-

ment in the machinery for manufacturing wrought nails or spikes, he obtained a second patent, dated December 2, 1834. This last modification was a change in the first machine for making counter-sunk railroad spikes for flat rails, in use for tracks on the first built railroads in the United States. In the winter of 1835-36, HENRY BURDEN visited England, and while there learned that the much used flat rails would likely be superseded by the "T" and "H" rails then coming into favor, and that also a different kind of railroad spikes would necessarily be used. On his return home he reconstructed his machines, and began the manufacture of the new hook-headed spikes. In 1836 he filled his first contract for this kind of railroad spikes, with the Long Island Railroad, making ten tons of them for this company. In 1840 he was granted a patent for his hook-headed spike machine.

THE STEAMBOAT HELEN.

Believing that he could construct a steamboat which would have a less draft of water than the boats at that time plying on the Hudson, and which would move more rapidly on the water, he, in 1833, built one, the lower deck of which rested upon two long cigar-shaped hulls, 300 feet long, placed parallel, about twelve feet apart, with a paddle-wheel amidships, thirty feet in diameter. The first trial trip of the new boat, which was named "Helen" in honor of his wife, was made on Wednesday, December 4, 1833. Her speed was tested in July, 1834, and was rated at eighteen miles an hour. Shortly after this, on an excursion down the river, by a misunderstood order from the pilot, the engineer ran the boat against the Castleton dam, which accident rendered the "Helen" worthless. A second boat with additional improvements was launched in 1837, and was highly commended for its special merits by different newspapers. These various improvements were all patented by their ingenious author.

A far greater is found in that development of processes making for the welfare of men in which he bore so noble a part. He spent a lifetime in devising means for lightening toil, and so helping to make the world a brighter, better, and more joyous one.

That fortune came to him in the prosecution of his labors was but a fair recognition of his deserts. His gain in that respect was only that which is due to one who does so much to elevate the condition of the whole race.

MR. BURDEN'S REMARKABLE PLANS FOR THE CONSTRUCTION OF INLAND AND SEA-GOING STEAMSHIPS.

The fact that HENRY BURDEN was the first advocate of the plans at present adopted by English and American shipbuilders in the construction of *long* vessels for ocean navigation has never been historically noted, and yet such a statement, at this time, is as true as it is remarkable. The principles which his inventive thoughts suggested almost half a century ago have not only been successfully applied in the building of ocean steamships, but they have been sufficiently tested to satisfy the most doubtful that they are the only correct ones which will enhance the speed, capacity and safety of sea-going vessels.

As early as 1825 he laid before the Troy Steamboat Association certain original plans whereby the constructions of steamboats for inland navigation could be greatly improved, and which some years later were adopted in the building of the steamboat "Hendrick Hudson." Besides increasing the length of the boats, he wisely suggested for the convenience and accommodation of passengers, the erection of sleeping berth-rooms, on the upper decks, being a decided change from the holds of vessels where they had been previously placed.

In 1846 he was so firmly convinced of the correctness of the principles which he advocated in regard to the building of ocean steamers, that he proposed the formation of a transatlantic company, to be known as "Burden's Atlantic Steam-Ferry Company," in the prospectus of which were fully set forth his suggestions in respect to these desired improvements. His proposed plans, it will be perceived, are clearly advanced in the subjoined paper, issued at Glasgow, Scotland, in 1846:

PROSPECTUS OF BURDEN'S ATLANTIC STEAM-FERRY COMPANY.

Managing director, H. Burden.

Engineers, L. Gordon and L. Hill, Jr.

Considering the vast and increasing population on both sides of the Atlantic, the extent of their mercantile transactions with each other, and the enormous sums which are annually spent on both continents in perfecting the *land* communication, it becomes a most important object to improve the present comparatively defective means of passing the Atlantic ocean.

The benefits that would accrue not only to this country, the United States and the Canadas, but to the whole continents of Europe and America, if the voyage, still so tedious, uncomfortable, and expensive, was rendered at once safe, expeditious, comfortable, and cheap, are too apparent to require illustration.

That those who could guarantee these results would reap a splendid return there can be little doubt, and of this, the rapid and profitable increase of railway business is a forcible illustration.

The present Atlantic steamers, magnificent though they be, are as inferior in their results to what they may become, as a well-appointed stage coach is to a railway train.

How this desired improvement is to be accomplished may at first appear no easy matter, but in reality it is a problem *already solved*. The wonder is that so rich a field should have lain so long neglected, when the means of insuring so splendid a harvest are so much within our reach. All experience in steam navigation shows that increase of size and power has been invariably attended with increase of speed, economy, and comfort. Witness the successive and gradual advance from the first boat on the Clyde to the last built ships of the Transatlantic Company; compare the performances of Henry Bell's little forty feet boat with the present Liverpool steamers, which now make the *trips* from Glasgow to Liverpool in little more than double the time the Comet made her *voyage* to Greenock; or compare the laborious efforts of the earlier Hudson river steamers, when the time required was thirty to forty hours from New York to Albany—

compare these with last summer's performances of the steamer "Hendrick Hudson," which daily carried 300 or 400 passengers between these places, a distance of 150 miles, in seven and one-half hours, and that with all the comforts of a first-class hotel, for six shillings.

The present company propose to carry out the suggestions of our countryman, HENRY BURDEN of Troy, U. S., to whose skill and foresight the present speed of the Hudson river navigation is mainly owing,—(he having laid before the Troy Steamboat Association, so early as 1825, and then strongly urged the adoption of, the identical proportions which have now been successfully carried out in the steamer "Hendrick Hudson")—and to establish boats of power, dimensions and strength sufficient to make the passage from Liverpool to New York in eight days *certain*—so adapted for their purpose, in fact, as, *auspice Deo*, to defy the wind and the waves. The first vessel will be about 500 feet long. The strength requisite for such a length can be fully obtained without detracting much from the vessel's tonnage; and as it is now known that the height and force of the waves are limited, it is obvious that the strength of a vessel may be so increased as to render the largest waves perfectly harmless.

This is proposed only as the beginning of a system which must ultimately be carried much further. The "Great Britain" steamship is 322 feet long, and those who have seen her are only amazed at the lightness of her framing. Those who have sailed in her, testify that the "pitching," even with her length, is very much reduced. That her speed is not proportioned to her size, is owing to some imperfection of her form, and defective system of propulsion.

That the passage will be made in the time proposed, or probably in less, there can be little doubt, when it is stated that the proportion of horse-power to tonnage will be nearly double that of the usual allowance; and such an engine, with boilers of the requisite capacity, can be erected without encroaching on more of the ship's tonnage than is the present proportion. The cost of equipment, etc., of such a vessel will be about £120,000; but it is proposed to make the capital £150,000.

That such expenditure would be amply remunerative there can be little doubt. Experience proves that traffic increases in proportion to the population of the districts accommodated, and inversely as the time and price of transit.

There are millions on each side of the proposed ferry (for ferry it will ere long become), and in this point of view the traffic will be illimitable. From New York to Liverpool is clearly the line of communication, and a glance at the maps show the innumerable feeders to the one grand trunk. Boats of the dimensions proposed would carry from 400 to 500 passengers with infinitely greater comfort than the vessels hitherto established, and as their regularity may be guaranteed, the returns shown in the following statement may be confidently relied on:

One boat, two trips per month:

400 passengers at £15.....	£6,000 00
1,200 tons light goods at £5.....	6,000 00
	<hr/>
	£12,000 00
	<hr/> <hr/>

Expenses per trip, including outlay at 10 per cent. on capital:

1,000 tons of coal, shore and other expenses	£3,000 00
Aside for surplus fund	1,000 00
	<hr/>
	£4,000 00
	<hr/>
	£8,000 00
	<hr/> <hr/>

Twenty-four trips per year is £192,000 or upward of 120 per cent. on the proposed capital, without taking into account letters, parcels or steerage passengers, one or two hundred of whom can be also accommodated.

No. 141 BUCHANAN STREET, GLASGOW, 9th Jan. 1846.

In 1851, when the "Arabia" of the Cunard line was built, having a length of 285 feet, being the extreme yet reached in any steamer built of wood, either on the ocean or on inland waters, a

professor of mathematics in one of the English universities, it is said, made it absolutely certain by scientific proof and a large array of figures, that, first of all, the "Arabia" could not possibly obey the helm; and secondly, that she would break to pieces in the mid-Atlantic, as the wooden hull would not be able to bear the strain put upon it for more than half the length of the voyage.

It will also be seen, by reference to the length proposed for sea-going vessels, by HENRY BURDEN, that the steamship "Gallia" lately put on the Cunard line, the length of which is 456 feet, embodies one of the chief principles laid down by him for the construction of ocean steamships, viz.: that their length should be about 500 feet.

At the time of the building of the "Great Eastern," in 1857, HENRY BURDEN wrote to the designer of the vessel's hull that to increase its speed its proposed proportions should be somewhat changed, or else she would prove a failure in that respect. His suggestions were not heeded, and the vessel did not accomplish what she was designed to do, as far as her sailing qualities were concerned.

In plates for iron-clad sea-going vessels HENRY BURDEN was also among the first to suggest their use, and he went so far as to manufacture at his works in this city a number of specimen plates to be sent to Glasgow, Scotland, for examination.

THE GREAT WATER-WHEEL OF THE WORLD.

So great became the demand for BURDEN's machine-made spikes that it was found necessary to increase the water power by which to operate the newly introduced machinery of the Troy Iron and Nail Factory. The five separate water-wheels, at this time in use in the mill, it was evident to HENRY BURDEN, were less effective and required more water than a single larger wheel, and which, by properly placed buckets, would more than double the power given by the smaller wheels. Having carefully considered the wants of the manufactory, he in 1838-39 constructed the immense water-wheel which Louis Gaylord Clark has figuratively called

www.libtool.com.cn

www.libtool.com.cn



The Water Wheel

www.libtool.com.cn

"The Niagara of Water-Wheels." In 1851 the old wheel was replaced by the present one, which is hereafter described. Standing upon one of the galleries winding about its huge frame, the visitor beholds this mighty wheel majestically doing the work of twelve hundred horses. It is an overshot wheel, sixty feet in diameter, and with a width of twenty-two feet. Around its broad periphery are thirty-six buckets, six feet three inches deep. Six hollow cast-iron tubes form the axis of this great wheel, which are keyed into flanges, seven feet in diameter, and from each flange diverge iron-rods two inches thick, 264 in number, which terminate at the circumference of the wheel. The water which sets in motion this remarkable wheel flows from a reservoir-dam, about 1,200 feet distant, through a canal to the distributing reservoir, having a head of eighteen feet above the wheel.

Going to the inner side of this wonderful wheel the visitor sees a man seated on an elevated platform, in front of it, having his hand on a lever, by which he increases or diminishes the volume of water, so that the revolution of the wheel may be governed to a second of time and its power regulated to whatever amount of force is required by the various machines in operation. Looking upon the trains of rolls, the rotary squeezers, the furnace blowers, the horseshoe, rivet and punching machines, and the other appliances in motion for manufacturing iron, one sees more appreciatively the immense power furnished by this huge wheel constructed by the master-mind of HENRY BURDEN. Although the celebrated wheel on the Isle of Man has a circumference of seventy-two feet, its buckets are only six feet long and its estimated power is only 200 horse. Through the persistent efforts of HENRY BURDEN the supply of water in the Wynantskill was largely increased by the building of large storage reservoirs in the vicinity of Sandlake, where, by connected channels with the different lakes, a great body of surplus water is kept to feed the Wynantskill in seasons of drought. A short distance east of the water-mill is a reservoir covering fourteen acres of land, made by him in 1846, from which water flows to move the great water-power wheel of the world.

THE ROTARY CONCENTRIC SQUEEZER.

www.libtool.com.cn

One of the most remarkable and valuable inventions devised by HENRY BURDEN is a simple contrivance known as the "Burden rotary concentric squeezer," for which he received a patent in 1840. In 1838-39, when the great water-wheel was approaching completion, the millwright discovered that no provision had been made for the forging hammer which had been previously used in preparing the puddled balls for the rolls. Reminding the great inventor of this supposed oversight, he was informed that he had no use for it, as he had conceived a different principle and a more rapid method for the treatment of iron at this stage of its preparation. Going to the pattern shop he returned with a model of the machine he intended to use in the place of the formerly employed hammer. The action of this simple contrivance may be illustrated by taking two pieces of pine board, about twelve inches long and three wide. On the two lengthwise edges of the one, let two flange-like strips be nailed, the projecting rims of which gradually diminish in height from one end of the board to the other, so that when the other board is placed over it the opening at one end is somewhat smaller than the aperture at the opposite end of the boards. Insert in the larger opening a ball of putty, and move the upper board along the tapering flanges in the direction of the smaller opening. It will be found that when the upper board clears the lower one, the ball of putty has been moved along the entire length of the lower board and has been changed from its globular form into a cylindrical one, and that in making this transformation it has been compressed and uniformly acted upon by the upper board. Although this may convey to the reader's mind the principle of the action of the squeezer, it must be remembered that the compression of puddled balls into blooms is done by revolving cylinders with concentric surfaces, and not longitudinally, as illustrated. This machine was declared by the Commissioners of Patents to be the first truly original and the most important invention in the manufacture of iron known up to that time which had been sent to the patent office. As soon as its invention was known, it was introduced into all the iron manufac-

tories of this country and Europe. When the renewal of this patent was considered, it was testified by certain iron manufacturers from Pittsburg that, during the short time it had been used in that city, a saving of \$530,000 had resulted therefrom. Go where you will, in this country, Great Britain, or on the continent, in all the leading iron manufactories, you will find "Burden's rotary concentric squeezers" in constant use and meritoriously commended.

THE FAMOUS HORSESHOE MACHINE.

The most notable machine constructed by **HENRY BURDEN** was one for making horseshoes, for which he obtained a patent in 1835. Five years previously he had invented a machine for making horseshoe nails. From the peculiar character of the horseshoe machine and the rapidity with which it fashioned a heated bar into a perfectly shaped horseshoe, this remarkable machine has attracted general attention to the excellent quality of the shoes made by it and to the important political benefits it has conferred upon the country. When first put into operation, large numbers of visitors flocked to the Burden mill to witness its effective action and to marvel over the prodigious number of shoes it was daily making. The ingenious inventor was not, however, satisfied with this first machine. It was his desire to construct a machine which could take a bar of iron from the roll-train and finish a shoe without reheating. In 1843 he added other improvements to it, which reduced its operations to two movements, and again in 1857 so that after receiving the heated bar, it cut, bent and forged it into a perfectly shaped shoe in one movement. In 1862 he made other improvements to this wonderful machine, all of which were patented. The excellence of these machine-made shoes, in a short time, created a great demand for them throughout the United States.

The mention of the political importance of manufacturing horseshoes by machinery may, at first, seem to many persons a bit of local gasconade, yet had not **HENRY BURDEN** discovered this mechanical method by which hundreds of thousands of these articles could be made, it is very likely that some of the

most important cavalry movements during the late Civil War would not have occurred with their advantageous results to the Federal armies. Among the many surprises which foreign officers encountered while personally inspecting our armies in the field, at that time, was the abundance of the supply of horse-shoes for the million of horses and mules employed in the service. There is no brighter lustre to the honors of this leading industry than the glorious fact that Trojan skill and machinery were prominent factors in the organization of our large armies and in keeping them constantly supplied with this particular and useful munition of war. The government having some time previous to the rebellion adopted the Burden horseshoe, at the outbreak of the civil strife, at once increased its orders, and when our military operations had assumed their later gigantic proportions, its demands for these horseshoes were astonishingly immense. The Confederate government having, in the first years of the war, obtained by frequent successful battles and forays large quantities of these machine-made shoes, did not for some time labor under any disadvantages for want of them. However, later, the supply of these shoes began to be exhausted, and necessity compelled that government to take steps at once to supply its pressing need of this important munition. It was deemed advisable on the part of the Confederate government to make preparations for their manufacture, should it be possible to obtain patterns of HENRY BURDEN'S horseshoe machines. It was proposed that a man named Moses, then residing in Toronto, Canada, but formerly of Atlanta, Ga., should visit Troy and secretly secure plans of these machines, for the purpose of establishing manufacturing works at Atlanta. This surreptitious enterprise, however, was frustrated by Gen. Sherman's famous march to the sea.

Besides the United States government, England, France, Austria, Prussia, Russia and other European governments availed themselves of the benefit of this useful patent. An amusing incident is told in connection with the purchase of one of these horseshoe machines by the Austrian government. A machine was to be set up and put in operation in Styria, the

government supplying the necessary workmen. While this work was in progress, large crowds of idle people gathered about the place, indulging their curiosity in watching the erection of the machinery. To prevent their interference with the workmen, ropes and guards were placed around the attractive object. When at last the machine was set to work and began greedily devouring the iron bars given it, and to cast at their feet more horseshoes than they could count, these superstitious spectators, regarding the machine as a supernatural monster, fled the premises in wildest confusion, and could not be persuaded to return to witness its further operations while the Americans had charge of it.

It is no little fame for Troy to have it known that at these works, now in possession of the sons of HENRY BURDEN, were manufactured the first ship spikes, the first "hook-headed" spikes, and the first horseshoes ever made by machinery in the world.

A MILE OF BUILDINGS.

As one reviews the intervening years from the time that HENRY BURDEN in 1822, as superintendent, took charge of the Troy Iron and Nail Factory, to the time of his death, January 19, 1871, when he was the full owner of the immense establishment, known generally as the Burden Iron Works, he is more sensibly impressed than ever with the remarkable genius with which this man was endowed by nature. With more than ordinary foresight he caught glimpses of that future in which there were immediate and immense demands for the various articles produced by his machines, and he failed not, with excellent judgment, to make, in time, the necessary preparations for this enlarged business. Personally, for himself, he purchased from time to time shares of the stock of the Troy Iron and Nail Company, until, in 1835, he owned about one-half of the stock of the corporation. For his assignment to the company of the patents of his spike and horseshoe machines, he was allowed 30 per cent. of the net earnings of the entire works. In 1848 he became possessed of the company's entire interest in the works, from which time the establishment has

been wholly controlled by him or by the firm of H. Burden & Sons, now consisting of his two sons, James A. and I. Townsend Burden. The little wooden mill which he entered as a superintendent long ago disappeared to give place to his larger works, which to-day, were they to stand in one alignment, would occupy a tract of land a mile in length. This immense establishment comprises two works — the "upper works," or water-mills, on the Wynantskill, a short distance east of the Hudson river; and the new works, called the "lower works" or steam-mills, located on the "farm company" property, and the "Hoyle farm," embracing about forty-five acres of land between the Hudson River railroad and the river, extending from the Wynantskill to the Clinton foundry.

The "upper works" embrace the following buildings:

A rolling-mill and puddling forge, 358x136 feet.

A horseshoe factory, two buildings, one 125x34 feet, and one 120x50 feet.

A rivet factory, 120x80 feet.

A horseshoe warehouse, semi-circular, 168x120 feet, containing 16 large bins, in which can be stored 7,000 tons of horseshoes.

A scraphouse and shop, 175x50 feet.

Here are also the general business office, a supply store, a rivet warehouse, the stables, etc.

The "lower works," or the new works, embrace the following structures:

Two blast furnaces, each 65 feet high and 16 feet at their boshes, with two casting-houses, each 92x47 feet.

Two stockhouses, each 114x65 feet.

An engine-room, 85x50 feet.

A puddling forge, 492x83 feet.

A rolling-mill, 421x96 feet.

A swaging shop, 271x45 feet.

A punching shop, 253x45 feet.

A horseshoe warehouse, 318x60 feet.

A square building, containing offices, blowroom, etc., 96x96 feet.

A machine shop, 140x57 feet.

A blacksmith shop, 130x55 feet.

A foundry, 250x57 feet.

A pattern shop, 85x55 feet.

A tin and plumbing shop, 64x55 feet.

A building containing a supply store, draughting-room, laboratory, etc., 105x55 feet.

An iron warehouse, 167x55 feet.

The erection of these works began in 1862, several buildings of which have been recently completed. This property has a river frontage of nearly a mile in extent, and an average elevation of eleven feet, being one foot higher than the track of the Hudson River railroad, east of it. The ground, before the erection of these great buildings, was low, and on account of periodical freshets made dangerous to persons residing thereon. At great expense, these low grounds have been filled up and made valuable to the owners. The depth of water in the river adjacent to the works was shallow and full of bars, but by dredging, an average depth of about fourteen feet has been obtained and made H. Burden & Sons' docks accessible to the largest vessels plying on the upper Hudson.

ACRES OF MACHINERY.

For the manufacturing purposes of these extensive mills a great amount of machinery is required. Could all the machines which are now in constant operation in these buildings be placed together in an open space of ground, it is more than likely that they would occupy more than a half score of acres of ground. Not to refer to their respective dimensions, the various classes of machinery found in the upper and lower works combined are the following:

Sixty puddling furnaces.

Twenty heating furnaces.

Fourteen trains of rolls.

Three rotary concentric squeezers.

Nine horseshoe machines.

Twelve rivet machines.

Ten large and fifteen small steam engines.

Seventy boilers.

One large water-wheel, already described.

In and about the building of the lower works is a net-work of railroad tracks, upon which daily are to be seen moving trains of cars conveying iron ore, kaolin, sand, stone, etc., to the different departments, or being loaded with horseshoes and merchant-iron for distant purchasers. For shifting these cars from place to place, H. Burden & Sons own a locomotive, which is in constant requisition.

The steam derricks used for unloading coal from boats in the river, which attract so much of the attention of passengers on the passing steamboats, when going by the docks of the lower works, the invention of the late William F. Burden, are very ingenious contrivances, peculiar to these mills. Each one of these labor-saving appliances consists of two lofty wooden frames, placed one at the dock and the other at the rear of the coal-heap, some 300 feet distant. A strong wire cable is stretched over these frames, on which an iron carriage travels to and fro, carrying a self-dumping iron bucket, which has a capacity for holding about a ton of coal. The power is furnished by a steam engine near the rear frame which hoists the bucket filled with coal from the boat to the cable and conveys it back to the point where is fastened the tilting apparatus that overturns its contents upon the pile.

Alongside of these mammoth heaps of coal are seen vast deposits of iron ore. These are chiefly brown hematite and the dark magnetic ore of Lake Champlain. Here, too, are piles of a fine quality of limestone, brought from Hudson, N. Y., which is used as "flux" to aid in the fusion of the ores.

THE ROMANCE OF MAKING HORSESHOES.

The processes by which the mined iron ore is melted and moulded, the cast metal puddled and cut into small bars, these reheated and fashioned into long, narrow rods, to be passed

to the horseshoe machines, are of peculiar interest to a spectator, and seem to him, like a dreamy romance, full of strange incidents and unthought-of dispositions. Step by step let him follow these different metallurgic operations, if he wishes to discover what are the secrets which are behind the smoky curtain that nature here places about these great furnaces and dusky forges. Entering the engine-room he inspects the admirable action of the two splendid engines, each of 250 horse-power, projecting a stream of air for the blast of the furnace; and here also are two Worthington pumps for supplying with water the boilers and other machinery of the mills. Here he sees the carefully kept hydrometrical, thermometrical, and barometrical statistics, the number of the total "charges" of ore as regards their character and weight, the amount of coal and of limestone, the quality and the quantity of the pig-iron made, the pressure and the temperature of the blast, and other important data. The blast furnace that to him had a close resemblance to the high walls, strong towers and lofty battlements of an ancient castle, as he first viewed it from the windows of the cars on the Hudson River railroad, he now sees is a massive brick and stone structure, sixty feet in height. Alongside of the extensive heaps of iron ore and limestone are groups of men filling hand-barrows, which with their contents will soon be hoisted to the top of the furnace. Before doing this, the ore in the barrows is weighed. Stepping upon the platform of the "elevator," upon which have been run several of these barrows of ore and limestone, he soon is carried upward until the fuming breath of the heated furnace fills his nostrils and warns him of the internal fires raging within its capacious depths. Here he sees a chimney-like structure over the mouth of the furnace supported by six iron columns, each of which marks a division into which at set intervals a certain number of barrows of ore, limestone, and coal are dumped in order to keep the furnace filled evenly to its mouth. Through this great quantity of burning and melting material is a heated blast of air pouring night and day the year round, and the molten metal flowing down into the hearth below where it is tapped and run-off into the casting-house. Over

the floor of this building is spread a covering of sand two or three feet deep, which is called "the pig-bed." Longitudinal trenches are made in this bed, which are termed "sows," from which at right angles are formed smaller trenches or "pigs." When the molten metal flows from the furnace it runs through and fills these trenches, where it slowly cools, and when taken out it is known as pig-iron.

THE WONDERS OF THE PUDDLING FORGE.

The chemical elements of pig-iron are such as to render it unfit for any serviceable use in these mills, and it therefore undergoes another process of melting in the puddling furnaces, where it is subjected to currents of air and flame while agitated by tools in the hands of the puddler. This manipulation brings it in contact with oxygen, which drives out the carbon in the pig-iron, leaving the metal afterward in a decarbonized condition.

In this temple of Vulcan — the puddling forge — the visitor beholds a scene of stirring activity seldom witnessed elsewhere. Scattered in groups or dispersed singly through this spacious building are hundreds of brawny men, with faces bedewed with perspiration and begrimed with coal dust, nude to their waists, their feet incased in heavy hob-nailed shoes, and their strong hands turning, thrusting, pulling, and piling the molten or fashioned iron in ways innumerable amid the heat, the smoke and the short-lived splendor of a thousand red-hot metallic sparks. Here are sooty-faced men stirring through the open doors of flaming furnaces, glowing incandescent masses of iron that blind one's eyes with their fervent brilliancy; others again are taking great balls of puddled metal from the furnaces in iron buggies and casting them into the devouring jaws of the rotary concentric squeezers, from which, as unpalatable morsels, they are ejected in the shape of compact blooms which are immediately taken up red-hot as they are, and thrust between a pair of revolving cylinders, placed one above the other, and furnished with grooves of various sizes through which the

www.libtool.com.cn

www.libtool.com.cn

www.tbtool.com.cn



Mills on the Weymouth Hill.

www.libtool.com.cn

bloom is run forward and backward, until it is shaped into a long bar of crude iron. The bars which have already cooled are then carefully tested by placing the end of each one on an anvil, where it is cut and bent before it receives its classification. These are then carried on cars to a great pair of iron shears, where they are cut as if they were ribbon, into pieces about three feet in length. These pieces, a number of them called "a pile," are again placed in furnaces, where they are reheated and again taken out and passed through the roll-trains, whence they issue, like long fiery serpents, in narrow bars, and passed to the horseshoe machines.

SIXTY HORSESHOES MADE IN A MINUTE.

Watch this wonderful piece of mechanism at work, which in a second of time makes a horseshoe. Before you are two strong frames between which are four revolving shafts geared together and getting their motion from a pulley-wheel. On the shaft most exposed to view, you see three cams, one of which raises a cutting lever, another lifts a bending frame on which is a bending tongue, and the third works the flattening pieces. This shaft also gives motion to the feed rollers. The center shaft revolves an iron wheel upon the periphery of which, at opposite points, are two iron dies to give form to the upper or concave side of the shoe,—the side that is next to a horse's hoof. Another shaft in like manner revolves a die which gives form to the lower part of the shoe. These several dies are curved in form and "mash" into each other, at each revolution of the shafts. The shaft which carries the shaping apparatus has also two cams for working side levers which close in the heels of the shoe. The creasing shaft bears an iron block to which are attached the "creasers."

Observe now the rapid movements of these shafts and their appurtenances. Gliding like a fiery serpent, you see a red-hot bar of iron, moving toward the machine, on the feeding rollers. Already the iron jaws of the monster are opening to catch between its incisive teeth this glowing rib of iron. The end

of the bar has passed to the opposite side of the ravenous automaton's mouth, which is the proper measurement of the length of the intended shoe — the cutter comes up and severs it, and for an instant stops the feed; the bending tongue raises up and is pushed against the cut bar and bends it between two forked cams; it is then caught between the upper and lower dies, taking their impression, the bending tongue falls back, and the side levers close in the heel-ends. While yet upon the center shaft die, a partial revolution carries it against the creasing die, where it is creased and receives the indented marks for the nail-holes. A little farther around, it is taken from the lower die by two knives and falls down and is then carried by an endless chain of linked pieces of malleable iron to the punching-room. In the latter are seen a long line of men seated astride of the saddles of the punching machines making the nail-holes through the indented marks previously put in the creased part of the shoes. Thence they are conveyed in hand-cars to the swaging furnaces in which they are placed before they are swaged.

Boys are at work here, taking with tongs the heated shoes from the furnace and putting them singly on the revolving dies of the swaging machine. After the heated shoe is seated upon one of these dies, it is carried to the top of the machine where it is stopped for a moment; a top die descends on it and two side steels swage the sides of the shoe, removing all bulges and making the outside edges of the shoe perfectly smooth; thence it is carried farther to the opposite side of the machine where there are two other side swedges which swedge up the heels of the shoe, thence it is carried beneath the machine where a wiper removes it from the die and the shoe falling upon an endless band of malleable plates is carried to the south end of the swaging shop where it is dropped off to cool and to be rigidly inspected before being transferred in hand cars to the bins of the shoe warehouse. The shoes when packed for shipping are then taken out, weighed and packed in kegs, in each of which are to be found 100 pounds of perfectly made horseshoes.

Above the lower openings of the great bins in the horseshoe warehouse are the printed names of the pattern and size of the different classes of shoes. There are three patterns of Burden's improved swaged horseshoes, namely, the light, medium, and heavy. As the visitor's eye glances along the long line of bins, he sees the sizes marked as follows: Horseshoes "fore," Nos. 0, 1, 2, 3, 4, 5, 6, 7; and "hind" of the same sizes; mule shoes, Nos. 1, 2, 3, 4, 5.

SHOES FOR MORE THAN TWELVE MILLIONS OF HORSES.

The stupendous manufacturing resources of H. Burden & Sons' establishment are really only comprehended by the visitor when he asks how many horseshoes the machines he has so intently watched produce annually. The answer that the works have a capacity for making 600,000 kegs, or about 51,000,000 shoes, is to him almost too amazing to be believed, and yet he has himself looked upon the practical evidences of this great power of production. The two warehouses, one at the upper and the other at the lower works, have storage capacity for more than 250,000 kegs. The nine horseshoe machines in use, which he has witnessed in their separate operations, can make sixty shoes in a minute. As he pictures to himself this army of twelve millions of horses that can be annually shod with the shoes made at these works, he realizes the important and useful character of the wonderful machine designed by HENRY BURDEN. Where are these shoes sold? Everywhere throughout the United States and Canada. Here in the lower warehouse a visitor, a day or two ago, could have seen hundreds of these kegs filled with shoes, their marked destinations being San Francisco, Cal., and Portland, Oregon. These shoes for their excellence of quality and finish have a world-wide reputation, and this single establishment, to which Troy points with pride, manufactures more horseshoes than all the other works in the world put together. The popularity of the new swaged horseshoes which have been made during the past few years by H. Burden & Sons had so much increased the demand for them

that the proprietors last year found it necessary to further enlarge their lower works, and since then their sales have been proportionately augmented.

EIGHTY BOILER-RIVETS MADE IN A MINUTE.

No less interesting than the horseshoe machines are the boiler rivet machines to a visitor. On one side of the rivet-factory is a line of furnaces, and between each two of the furnaces is stalled a rivet machine. The red-hot rod which the spectator sees the workman take from one of these furnaces is pushed through a guide up to what is known as "the header," where gripping dies seize it, cutters sever it, an iron crown puts a head on it, and the dies then open, it falls down into the receptacle below, the operation occupying a little less than a minute, in which time it is made into a perfectly formed boiler-rivet. The firm has of these machines twelve in use, each of which can make eighty rivets in a minute.

THE MANUFACTURE OF MERCHANT IRON.

In the spacious rolling-mill, 421 feet long by 96 wide, are to be seen ranged on one side of the building, a row of heating furnaces, each surmounted as in the forge-room, by large boilers for generating the steam for driving the many engines employed in these works. Through the middle of the building is a line of roll-trains; first, a ponderous roll-train for making the larger sizes of merchant-iron, driven by a splendid Corliss engine, then another train for making ordinary sizes of merchant-iron; then several pairs of steam-shears for cutting iron into pile pieces, then other smaller roll-trains for making small sizes of iron; and, at one end of the building, a steam saw-mill, for cutting off at one time both ends of a bar to its required length. Looking in upon the fire-lighted forms of the hundreds of half-naked men that are to be seen at night within this building, moving about the roll-trains, around which long, fiery serpents seem to coil and writhe, the observer is almost impressed with the belief that he has passed the fixed gulf and

is looking upon a veritable pandemonium, where spirits lost in company with gorgons, hydras, and chimeras, are vexed with unending labors,

“ Where peace
And rest can never dwell; hope never comes
That comes to all.”

Within this mill are made the various classes of merchant-iron which has acquired such enviable reputation as being a superior quality of manufactured iron. This noted excellence is no doubt due to the first-class ores and material used, to the superior furnaces and machinery employed in the manufacturing processes, to the constant care in testing and watching the work at every developing stage, and the long experience of the firm owning this extensive establishment.

FOURTEEN HUNDRED WORKMEN EMPLOYED.

The vast amount of manual labor that is necessary to aid in the production of the pig-iron, the rivets, the horseshoes, merchant-iron, etc., annually manufactured at the upper and lower works demands, at present, not less than 1,400 men. As a class, these men are not only industrious, but they form a body of respected citizens. Between their employers and themselves there have always existed the most amiable relations, and it has never been known that the workmen at the Burden mills, in any of their strikes, lost their sense of manhood so far as to jeopardize these friendly dispositions. Besides the Roman Catholic Church, which exercises a religious care over most of the families of these workmen, the Protestant Churches in the vicinity of the works are also acquiring an increased membership from their number. The additional improvements that are yearly changing the aspect of the open grounds in the vicinity of the lower mills, are gradually transforming their surroundings into more sightly and pleasant places of abode. However, as elsewhere, coal-dust and the dispreaded smoke of furnaces, are always and will ever be sources from which this part of our city will receive grimy driftings and undesirable dust.

THE OFFICES.

www.libtool.com.cn

As one enters the business office of the firm of H. Burden & Sons, and is made acquainted with the methodical manner in which this great business is managed, he more easily perceives how its multifarious details are personally known to its owners. There is not an item of expense or of profit lost sight of, but everything, however minute it may seem, is recorded in well-arranged books, to which at any time the inspective eyes of the firm may turn and be satisfactorily answered. The cost-books, in which the prices of all purchases or expenditures are entered, are models of artistic bookkeeping. When one sees an entry of 50-100 per cent. waste in coal dust in a certain process and other minutiae of expense respecting other things, he can comprehend the ability which devised these departmental records and their compendious data. The stock-books are similarly complete and useful. This office is connected by telegraph wires with a branch office at the lower mill and also with the Western Union telegraph office in this city. At the lower works, the department chemist has a laboratory, in which daily are made tests of the elemental composition of the ores, metals, etc., as they pass through each manufacturing process. Here are also made assays of metal and of bar-iron, and also such other practical investigations which need to be intelligently known to those manufacturing a superior quality of iron.

The business also requires a large number of horses and wagons to move ore, coal, sand, clay, and manufactured articles from the different mills. The firm is the owner of extensive iron mines containing a superior quality of ore. It also possesses a number of limestone quarries to meet the demands of its furnaces.

STARTLING STATISTICS.

The present magnitude of this industry is exhibited in the following startling array of figures:

Number of employees	1,400
Annual wages paid over	\$500,000

www.libtool.com.cn

www.libtool.com.cn

www.libtool.com.cn



Rivers Mills and Blast Furnace.

www.libtool.com.cn

www.libtool.com.cn



Rivers Mills and Blast Furnace.

www.libtool.com.cn

Capacity for manufacturing horseshoes, kegs annually	600,000
Capacity of works annually, tons, exclusive of pig-iron	42,000
Annual sales of horseshoes, variable price.....	\$2,000,000
Coal consumed annually, tons	90,000
Number of horses	50

FAMOUS BURDEN WATER-WHEEL.

In visiting the extreme southern section of the city to-day one sees a mark of departed activity in the ruins of the old iron mills and factories along the Wynantskill. Here the iron industry of Troy, for which the city was long famous, started in 1822, when a small slitting and nail-mill was established. This was owned by Albany parties who engaged HENRY BURDEN, a young Scotch mechanical engineer, as superintendent. Mr. BURDEN had letters to the Van Rensselaers, which helped him to secure the position. Before coming to Troy from Albany, he had distinguished himself by improving the flour milling business in this vicinity and by getting up an improved plow, which took the prize at the State fair.

Awakens Memories of Years Ago.

The old mill referred to was located near the falls east of the present Burden water-mill site. Mr. BURDEN, shortly after his connection with the plant, purchased the interests of the proprietors and built the water-mill now being razed. Interest in this mill centers in the famous overshot water-wheel originated and built by HENRY BURDEN in 1838. This mill, abandoned several years ago, was driven by what had been termed throughout the mechanical world, "The Niagara of Water-Wheels," and it is this at one time wonderful piece of machinery which now strikes the eye of the visitor to the southern section and not only commands his attention but awakens a lively interest. The masive wheel is fully exposed to view and has been during the past two weeks. The sight of it awakens memories of the past; it recalls days of wonderful prosperity in that section of the city and arouses a sentiment of love for the memory of the

departed inventor among many who had passed years of labor beneath the roof which sheltered the old wheel. Its present appearance, exposed to the elements and evidently in danger of destructions has also aroused a feeling of grave apprehension among residents of this city and Albany, and especially the Iron Works district, who are yet hopeful that the old relic of early hydraulic engineering and of Mr. BURDEN's genius may be preserved.

A Remarkable Invention.

The wheel is remarkable in many respects, especially for its bold mechanical features, it having antedated by many years the turbine. It has a world-wide reputation, and when it was in operation visitors from far and near came to inspect its mechanism and to marvel at its size and power, it having been the most powerful in the world, for its day and generation. A water-wheel larger in diameter was built in Wales but it was not so wide as the Burden wheel and was of much less power.

The Burden wheel is 60 feet in diameter, 22 feet in width, and the buckets are 6 feet deep. It made about two revolutions per minute, developing between 500 and 600 horse-power. It operated the entire mill and factories adjacent for many years until the water supply began to fail, when some steam-power was added as an auxiliary. On account of its many peculiar features, the wheel was a favorite subject for the graduating theses of the students of the Rensselaer Polytechnic Institute during the early '50's and '60's, it having been adopted for that purpose some half dozen times. Probably the first to have used the Burden wheel as the subject for his graduating thesis was Frederick Grinnell of the class of '55. Mr. Grinnell was from New Bedford, Mass., and he subsequently became a prominent figure in the engineering world, and particularly noted as having been an inventor of some forty appliances used in automatic fire extinguishers and alarms. George Frederic Kirby of Bainbridge, N. Y., class of 1857; Charles McMillan, class of '60, a former professor at the R. P. I., at Lehigh University, and at Princeton, and who designed and built the arched bridge and upper lakes in Oakwood Cemetery, also used the wheel as a subject for

their theses. Among others whose theses were on the same subject were Horace Crosby, '62, of New Rochelle, Westchester county, and Abraham Beekman Cox, '67, of Cherry Valley.

A Peculiar Feature.

One peculiar feature of the wheel is that its weight is not taken on the center journal as usual in most rotating bodies. It is really a rotating cylinder made up of eleven-inch square Florida pine timbers, rolling on two shafts underneath. These two shafts have two gears each, which engage the segment gearing on the periphery of the wheel, so the numerous one and one-half inch tie rods that extend to the center are more for the purpose of keeping the cylinder round and from flattening. The construction of the wheel from an engineering viewpoint is altogether ingenious. The center shaft and the two under shafts upon which it was to rest were first put in place. Then one of the Florida pine timbers forming the cylinder was suspended by rods from the center shaft, after which one timber after another was added to each side until the lower half was completed and tied to the center shaft by rods. Scaffolding was next built inside, upon which a temporary center was erected, the same as a form would be built for a brick arch, and the timbers were placed in position around it. After this was completed the temporary supporting frame was taken out, and the buckets were put on the outside. To do this men were put inside to revolve the wheel a few feet at a time by walking around as on a treadmill.

Foundation of the Burden Plant.

Notwithstanding the fact that the wheel has been in disuse for many years, it has continued to fulfill an office in the life of the city. It has been looked upon as a shining example of the productive mind of a Trojan inventor, and its existence has continued to remind residents of the southern end of the city of former prosperous times due largely to the founder of the now famous Burden Iron Works. This striking product of the mind of HENRY BURDEN has been a credit to Troy, and a monu-

ment of honor to the deceased inventor — a monument more noble than the tallest shaft of marble extant or than the mills now operated by his sons. This was the foundation of the present magnificent plant which still keeps his name alive throughout the industrial world. It was the product of an inventive mind far in advance of his generation, and its continued existence will serve to demonstrate his right to be ranked as a general of industry. In view of the interest taken in the old wheel and of its remarkable significance, it is hoped that the Burden Iron Company may see their way clear to preserve and keep it as a relic of HENRY BURDEN'S inventive genius.— *Troy Record*, July 27, 1903.

A POWER IN THE PAST

Many memories cluster around the old Burden water-wheel. For more than half a century it has been a wonder in its way. The most stupendous affair of its kind in the world, for years it was the propelling power of a great industry. Now it simply stands a landmark half a century old and reminiscent of what has been.

It was a mighty force in its days of usefulness, but is now related to the mill that "never grinds again with the water that has passed," nor with the water that is to come. Long ago it was known as the Niagara of water-wheels, with its 1,200 horsepower, thirty-six great buckets, its diameter of sixty feet and twenty-two feet of width. The discoveries of science have relegated the wheel to a sphere of inactivity. Its strength in operation now would be almost as nothing compared to the gigantic forces generated by steam and electricity as applied to machinery. Like thousands of other things in the world, it has seen its day and has now nothing but a history. There are old timers in the southern section who regard it almost with veneration and can recall the time when it was the moving power that kept a great factory going and was looked upon as a remarkable institution. It is many a day since it made a revolution. Dilapidation o'erspreads it and it is gradually disintegrating.— *Troy Press*, August 10, 1903.

WOODSIDE PRESBYTERIAN CHURCH

[North side of Mill street.]

Under the auspices of the First Presbyterian Church, a Sunday school was organized about the beginning of the year 1866, in Mechanics Hall, still standing on the south side of Mill street near the church.

At a meeting held on April 8, 1867, a number of Presbyterians, residing in that part of the city, determined to form a church, and engaged the Rev. John Tatlock of Williamstown, Mass., to take charge of it. At their request a committee of the Troy Presbytery on June 19, in Mechanics Hall, organized the South Presbyterian Church of Troy, with twenty-nine members: Elders, Richard Davidson, Thomas B. Cook, and Ira R. Wavell.

On January 24, 1868, a call was given the Rev. John Tatlock, "which, however, was not prosecuted before the Presbytery" and he resigned, on May 1, "his position as stated minister."

In May, the erection of a church and chapel was begun on land given by Erastus Corning and Henry Burden. The cornerstone was laid September 16th. The name of the organization was changed to that of the Woodside Presbyterian Church. About the middle of June, 1869, the chapel was first used for church services. On July 15 the church was dedicated. The cost of the attractive stone edifice, including the chapel at the north end of it, was \$75,000. Sittings, 300. A tablet on the interior side of the south wall of the church bears this inscription: "Woodside Memorial Church, dedicated to the service of the Triune God, has been erected to the memory of Helen Burden by her husband HENRY BURDEN, in accordance with long cherished and earnest desire, 1869." The new chapel, built of stone, east of the church and opposite the old chapel, is used by the Sunday school, and is admirably furnished. A Mural tablet in it is inscribed: "Woodside Chapel, Erected A. D. 1883, by Margaret E. Proudfit, James A. Burden, I. Townsend Burden, in memory of their children."

HENRY BURDEN died January 19, 1871. And as it was his intention to build a manse, his surviving children erected one on the west side of the church as a memorial to their father.

Pastors: Matthew B. Lowrie, called July 8, installed October 30, 1868, to December 26, 1870; Teunis S. Hamlin, installed September 28, 1871, to September, 1884; Arthur Huntington Allen, February 8, 1885, to present time.—*From the "City of Troy and Vicinity," by A. J. Weise, 1886.*

THE BURDEN TOMB AT THE ALBANY RURAL CEMETERY

From an exceedingly well-written sketch of the Albany Rural Cemetery, which we find in the Albany Times, we take the following: Next to the "Angel at the Sepulchre," the most attractive object in the cemetery, perhaps, is the Burden tomb. It is built in the face of a verdant slope and canopied in living green. Only the marble front and ornaments are visible. The material is chaste Tuckahoe granite. Two large sculptured dogs maintain their perpetual vigils over the last resting place of the tenants. In a circle on the front is the inscription: "Burden — 1850."

Before the tomb, on an elliptical plat, is seen a pulpit, artistically wrought, bearing a mammoth open book, upon the pages of which are the following inscriptions:

www.libtool.com.cn

www.libtool.com.cn

www.libtool.com.cn



Family Vault

www.libtool.com.cn

**INSCRIPTIONS ON PAGES OF BOOK — BURDEN VAULT —
ALBANY RURAL CEMETERY****SACRED TO MEMORY OF HENRY BURDEN**

HE WAS BORN IN STIRLING SHIRE, SCOTLAND, APRIL 22D, 1791. DIED, TROY, JAN. 19TH, 1871.

ENDOWED BY PROVIDENCE WITH AN INTELLECT MARKED BY STRENGTH AND ORIGINALITY, HE EARLY EVINCED A TASTE FOR THE STUDY AND APPLICATION OF THE LAWS AND FORCES OF NATURE AND BECAME THE AUTHOR OF SEVERAL MECHANICAL INVENTIONS, WHICH HAVE SERVED TO LIGHTEN HUMAN TOIL AND PROMOTE HUMAN HAPPINESS. THE RESULTS OF HIS CREATIVE GENIUS ARE KNOWN IN ALL PARTS OF THE CIVILIZED WORLD, AND HAVE SECURED HIM A HIGH PLACE AMONG THE BENEFACTORS OF THE RACE. COMMANDING IN PERSON: HONEST IN HIS DEALINGS WITH HIS FELLOWMEN: AFFABLE IN SOCIAL LIFE: LIBERAL IN HIS BENEFACTIONS: REFINED AND LOVING IN HIS FAMILY, WITH A SIMPLE FAITH IN THE REDEEMER, HE CLOSED HIS USEFUL LIFE ON EARTH AND ENTERED INTO THE REST WHICH REMAINETH FOR THE PEOPLE OF GOD.

SACRED TO THE MEMORY OF HELEN, WIFE OF HENRY BURDEN

SHE WAS BORN IN STIRLING SHIRE, SCOTLAND, FEBR'Y 13TH, 1803, AND DIED IN TROY, MARCH 10TH, 1860. NOBLE IN PERSON: REFINED IN MANNERS: PRUDENT IN COUNSEL: FAITHFUL IN FRIENDSHIP: GENEROUS IN BENEVOLENCE: SINCERE IN RELIGION: WITH ALL THE VIRTUES IN HAPPY COMBINATION.

SHE BEAUTIFULLY ADORNED THE RELATION OF DAUGHTER, SISTER, WIFE AND MOTHER, AND HAS LEFT AN EXAMPLE WORTHY OF STUDY AND IMITATION.

“A perfect woman nobly planned —
To warn, to comfort and command;
And yet a spirit still and bright
With something of angelic light.”

HER CHILDREN RISE UP AND CALL HER BLESSED; AND HER HUSBAND ALSO,
AND HE PRAISETH HER.

The beautiful Burden sepulchre, which is considered the model of hillside tombs, was, it is understood, in its essential features, designed by Mrs. Burden. Among its tenants is **HENRY BURDEN**, the late celebrated manufacturer, engineer and inventor, of Troy, of whom it has been said: "His name will be associated with those of Cartwright and Whitney, Fulton and Morse, the products of whose genius are now found in every quarter of the civilized world."

www.libtool.com.cn

INVENTIONS AND PATENTS

www.libtool.com.cn

APPARATUS FOR THE MANUFACTURE OF IRON

To all whom it may concern:

Be it known that I, HENRY BURDEN, of the city of Troy, in the county of Rensselaer, and State of New York, have invented an improvement in the process of manufacturing iron, which improvement consists in the employment of a new and useful machine for the rolling of puddle balls or balls prepared in the puddling furnace, and of other similar masses of iron, by which rolling they are moved perfectly and rapidly prepared for the process of being drawn out into bars by means of the rollers ordinarily employed for that purpose, or under the tilt hammer. My rolling machine dispenses with the shingling or other methods heretofore adopted of preparing the bloom for being drawn out into bars.

The puddle ball is conveyed into my machine immediately from the puddling furnace, and it is therein rolled down, and elongated between the plane curved surfaces, and made to assume a cylindrical form; a progressive motion being given to one or both of these surfaces during the time the mass of metal is between them, so as to cause the ball to roll over and over, separating from it a large portion of the cinder and other foreign matter, reducing it in diameter, and finally drawing it in a cylindrical form.

The machine as I now construct it consists of an iron cylinder which may be from four to six feet in diameter, and three feet, more or less, wide; said cylinder being in part surrounded by a trough-like stationary concave sufficiently distant from it at one end to admit the puddle ball, and gradually approaching nearer and nearer to it, along its whole length, until it arrives at the point at which the bloom is delivered in a state ready for the subsequent operations of the manufacture.

To exemplify the principle upon which my machine operates, I will, before describing it more particularly in the form in which I now use it, show it in that in which my first essays were made,

and which I have represented in Figure 1 in the accompanying drawings. In this figure, A represents a crank having a throw of four or five feet, and attached by a shackle bar to a wedge-formed piece of cast iron B, of corresponding length, and of sufficient width for the formation of the bloom; the piece B is supposed to be sustained, and to slide against the stationary guide, on top piece C, and above the bed piece D. If, in the position represented, the puller's ball E be placed between B and D it will by the revolution of the crank be rolled over and over, will be reduced in diameter, be brought into, and delivered in a cylindrical form as shown by the end view of it at E.

Figures 2, 3, and 4 represent my machine in the form in which I now construct it, and in each of the figures the same letters of reference are used to designate like parts. Figure 2 is a side view, Figure 3 a front view, and Figure 4 a diagram showing the relationship of the cylinder and the concave to each other. G G is the frame work of the machine, which may be made of cast iron. H is a cylinder of the cast iron, which is to revolve in said frame, and which may be from four to six feet, more or less, in diameter and three feet, more or less, wide. The surface of this cylinder may be even, or it may be furnished with protuberances on its periphery for the purpose of giving a kneading motion to the particles of the mass which is rolled, should this be preferred. L is a curved segmental trough of cast iron which partially surrounds the cylinder, and which is firmly attached to the frame G G. A ball of puddled iron J is represented as entering the mouth of the trough at I' I'; the form given to the trough, or concave, at that part being that of a semi-circle at its upper portion, and having parallel sides near to the cylinder. The curved trough becomes wider and shallower throughout the circuit intended to be given to the ball, until, at its termination or point of delivery K, its back I'' is parallel with the cylinder, whilst its sides, or flanches I''', I''' are so shaped as to act upon and upset the ends of the bloom which is consequently delivered in a cylindrical form such as is represented at J''', Figure 2. In the diagram Figure 2, the line H represents the outline of the cylinder, the line I I I

that of the interior of the trough, in a section along its middle, showing how the ball J must necessarily and progressively be reduced in its diameter as seen at the middle J', and until at J" it makes its escape in the form of a cylinder. L is the driving shaft of the machine, which carries two pinions, one of which is shown at M, Figure 2 mashing into the cogwheel N on one end of the cylinder; which end of the cylinder being similarly furnished with a cogwheel as shown in Figure 3; the second pinion similar to M is hidden by the other parts of the machine. O O is the shaft of the cylinder H, supported upon proper bearings.

In my establishment the puddling furnace is situated several feet above my machine for rolling the balls, and they are, therefore, most conveniently fed to the machine down an inclined plane represented by the line P, Figure 2. But in many, and probably in most situations, it will be more convenient to feed them in below and deliver them above, reversing the segmental trough for that purpose. The segment also may be made to surround nearly, or quite, three-fourths of the cylinder, only allowing sufficient space for the convenient entrance and delivery of the blooms. The cylinder may, if preferred, be made to revolve horizontally; the only change required in this case would be the turning the machine down on one side, and then adapting the dividing parts thereto.

It will be readily perceived also by the skillful machinist that the principle upon which I proceed may be carried out under various modifications, of which I have given two examples, and these may be easily multiplied, but this I do not think necessary, as I believe that those which have been given must suffice to show in the clearest manner the nature of my invention, and to point out fully that I desire to have secured to me under letters patent of the United States.

Having thus fully made known the nature of my said improvement, and explained and exemplified the manner in which I construct the machinery for carrying the same into operation, what I claim as constituting my invention and desire to secure by letters patent is the preparing of the puddler's balls as they are delivered from the puddling furnace, or all other similar masses of iron, by

causing them to pass between the revolving cylinder and a curved segmental trough adapted thereto, constructed and operating substantially in the manner of that herein described, and represented in Figures 2 and 3 of the accompanying drawings; or by causing the said balls to pass between vibrating or reciprocating tables, surfaces or plates of iron in the manner exemplified in Figure 1 in the accompanying drawings, or between vibrating or reciprocating curved surfaces operating upon the same principle and producing a like result by analogous means.

UNITED STATES PATENT OFFICE.

HENRY BURDEN, OF TROY, N. Y.

Improvement in Machines for Making Horseshoes.

Specification forming part of Letters Patent No. 3,261, dated September 14, 1843

To all whom it may concern:

Be it known that I, HENRY BURDEN, of the city of Troy, in the county of Rensselaer and State of New York, have made certain improvements in the machine for manufacturing horseshoes (for which machine I originally obtained letters patent of the United States, under date of the 23d day of November, 1835); and I do hereby declare that the following is a full and exact description of my said improvements thereon.

In the machine as originally patented by me the rod or bar of iron from which a shoe was to be made was cut off above the gripping-dies or side steels between which it was to be gripped and held while it was rolled and fashioned by the segment-swages, and after being cut off it was allowed to fall between them. In my improved machine the rod or bar is passed directly in between the gripping-dies, and is cut off by a cutter on a level with and at the outer end of said dies. It was found impracticable, also, in the machine as originally constructed to draw out and dis-

H. BURDEN.
MAKING HORSESHOES.

Patented Nov. 23, 1835.

www.libtool.com.cn

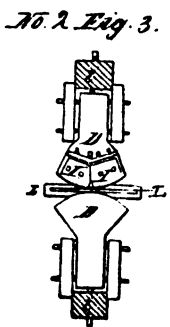
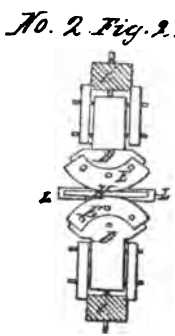
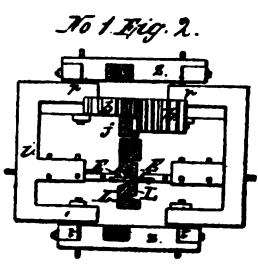
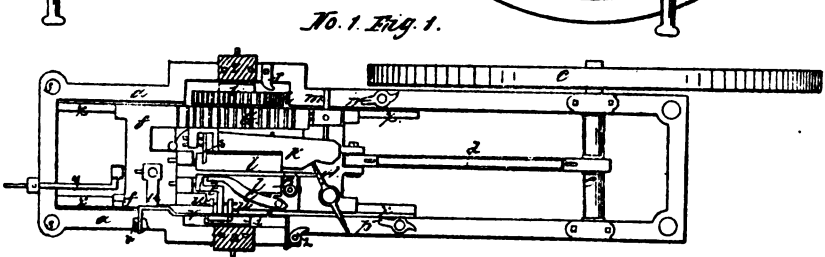
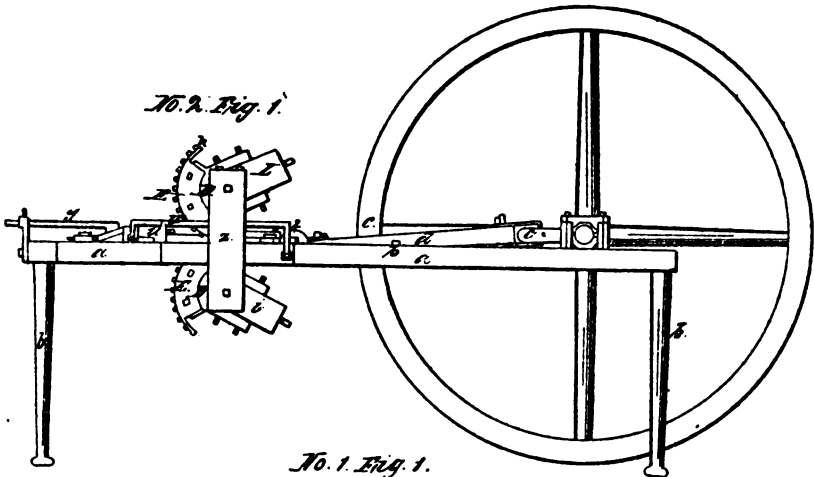

www.libtool.com.cn

H. Burden,

Horseshoe Machine,

N^o 3,261.

Patented Sep. 14, 1843.

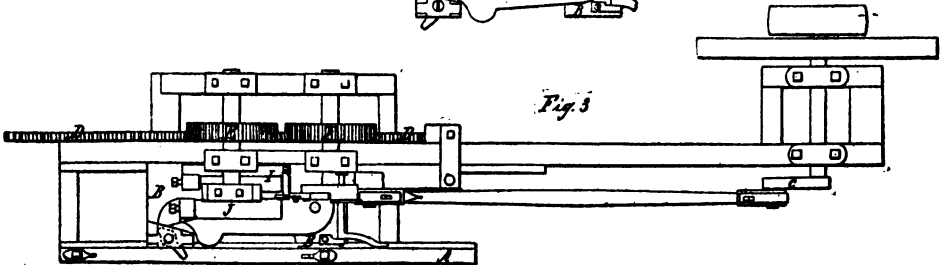
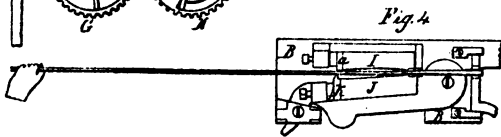
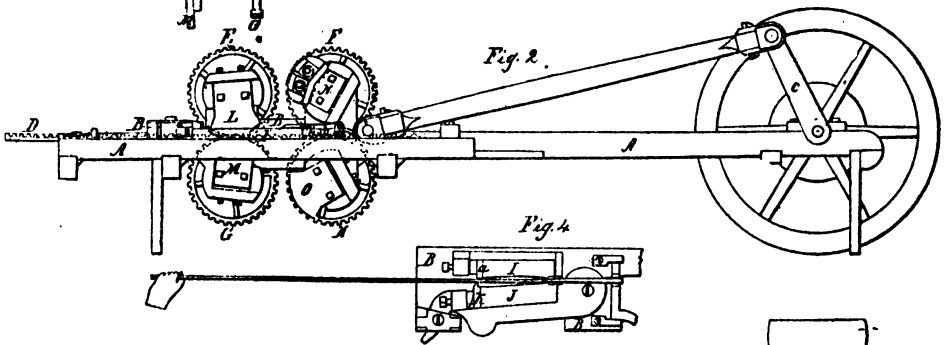
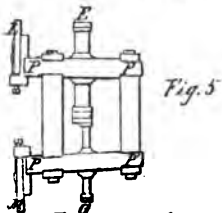
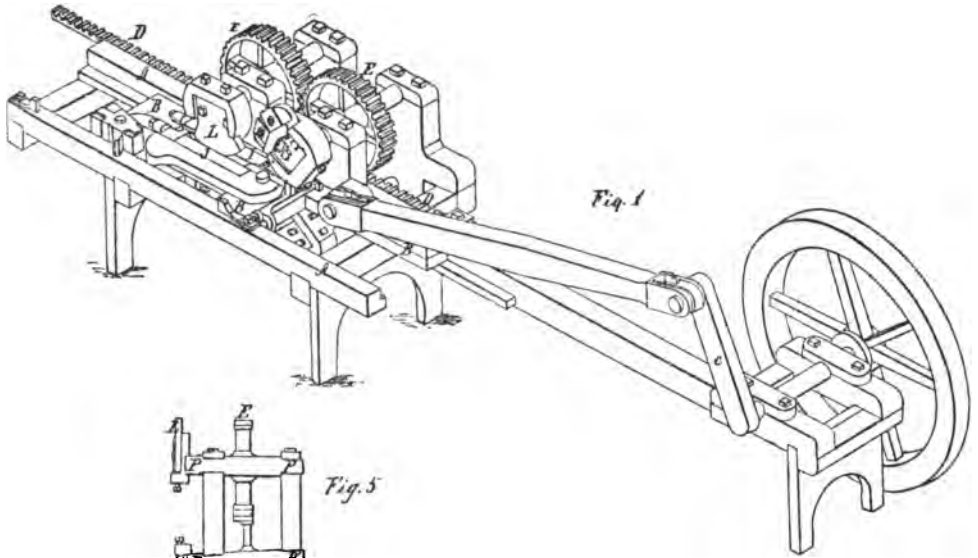

www.libtool.com.cn

tribute the metal by the action of the segment-dies used in that machine so as effectually to fill the space between the gripping-pieces, and thereby to give the metal the proportionate thickness and width requisite in its different parts. In my improved machine this difficulty is obviated by giving to the swages a somewhat greater extent of motion than is given in the same time to the sliding frame, by which means they exert a rubbing or drawing power on the metal, drawing it from the cutting end toward the rear, and thereby fill the space between the gripping-dies.

In my original plan the machine by which the iron was grooved and punched was distinct from that by which the rolling and drawing were effected. In my improved machine both of these operations are performed in succession on the same machine, thereby greatly diminishing the time required for their performance, preventing the loss of heat, and insuring greater accuracy in the work.

In the accompanying drawings, Fig. 1 is a perspective view of the whole machine. Fig. 2 is a side elevation, and Fig. 3 a top view or plan thereof.

A A is the main frame, and B B, a sliding frame, which is made to traverse back and forth upon the main frame by the action of the crank C. This and the general construction of my machine are similar to that first patented by me; but the sliding frame is longer and moves to a considerably greater distance.

D D is the rack, which is bolted into the sliding frame, and into this rack the wheels E F mesh, as they do likewise into the lower wheels, G and H, the wheels E and F being wide enough on the face to engage both with the rack and the lower wheels.

I is the stationary and J the movable gripping-die, which are shown separately in Fig. 4, the movable die being represented as open.

K is the cutter on the movable die J, which, operating against the end *a* of the stationary die I, cuts off the iron rod.

In the position of the machine shown in Figs. 1, 2, and 3 the cut-off piece is being acted upon by the rolling and drawing segment-dies L and M, and after passing these it is to be acted

on by the grooving and punching dies N, the piece being sustained by the lower segment-die O. When the piece has thus passed these segment-dies the gripping-dies will open, and the iron will be then prepared for the bending-machine, which is the same with that formerly used by me and fully described in the specification of the above-named Letters Patent. The opening and closing of the dies are effected in substantially the same manner as in my original machine.

To give to the segment-dies L and M the requisite drawing action I, in general, arrange the shafts of the wheels G and H so that they shall not be parallel to each other, as shown in the segment, Fig. 5. In doing this the inner ends, P P, of the shafts which carry the segment-dies L and M, are to be at a greater distance from each other than their opposite ends, P' P'. The distance of the peripheries of the segment-dies from their centers is to be proportionately increased, and the desired end will be thereby accomplished, as the peripheries of the segment-dies thus constructed will be made to travel somewhat faster than the sliding frame. A like end may be attained by placing the shafts of the segment-dies parallel to each other, and so gearing the wheels and rack as that the segment-dies shall move faster than the carriage; but the former method is the most simple and is perfectly effective.

Having thus fully described the nature of my improvements in the machine for manufacturing horseshoes, what I claim as new therein, and desire to secure by Letters Patent, is —

1. The manner of combining and arranging the cutters and gripping-dies in the said machine so that the former be in the same plane with the latter, thereby allowing the bar of iron to be passed directly in between them, as herein described and represented.
2. The causing of the peripheries of the segment-dies L and M to travel faster than the sliding frame and the gripping-dies, for the purpose and in the manner above made known.
3. The manner of combining the segment-dies for drawing out and distributing the metal with those for grooving and punching

H. Burden,

www.libtool.com.cn

Horseshoe Machine,

Patented June. 30, 1857.

No. 17,665.

Front Elevation.

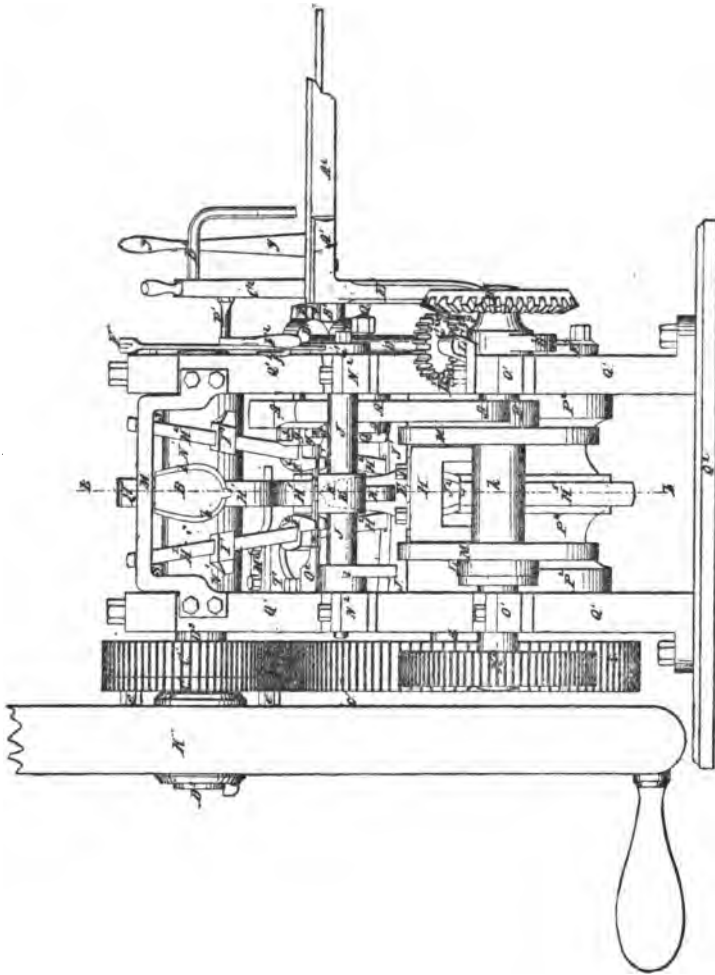

Inventor

Henry Burden

www.libtool.com.cn

it, so that the piece of metal shall be carried directly from the former to the latter by a continued movement of the sliding frame.

And for a full description of those parts of the said machine which it has not been thought necessary to present in the present specification I hereby refer to the original patent above named.

HENRY BURDEN.

Witnesses:

THOS. P. JONES,

EDWIN L. BRUNDAGE.

UNITED STATES PATENT OFFICE.

HENRY BURDEN, OF TROY, N. Y.

Improved Machine for Making Horseshoes.

Specification forming part of Letters Patent No. 17,665, dated June 30,
1857

To all whom it may concern:

Be it known that I, **HENRY BURDEN**, of the city of Troy, county of Rensselaer, and State of New York, have invented a new and useful Improvement in Machinery for Making Shoes for Horses and Mules; and I hereby declare that the following is a full and exact description thereof, reference being had to the annexed drawings, Plates I, II, III, IV, and V. They have all been made to a scale of two inches to the foot and correctly represent the form and sizes of the several parts in the different drawings.

My machine is designed to make shoes from rods as they are discharged from the train of the rolling-mill and without reheating. They are usually rolled square, of a size adapted to the size of the shoe, and are placed on leaving the train into a trough made of cast iron or other suitable material. It is represented in the drawings at A², Plates I and II, and is most conveniently made in sections of about twelve feet each. The end nearest the machine

is supported by a standard E' , attached to the side of the machine by two bolts. The other end may be supported by legs or other appropriate means.

The successive operations of my machine upon the rod are as follows: First a portion of it of suitable length to form the shoe is drawn into the machine and cut off. It is then bent around a form into the shape of the letter U . The heels of the shoe are bent still further inward, while it next passes between two revolving swaging-dies that compress and roll it into its proper shape. Then it is creased and punched, and finally it is taken from the dies and flattened and dropped in a finished state upon a revolving chain that deposits it in the storehouse. While one shoe is being creased and punched another portion of the rod is drawn into the machine, and thus it proceeds continuously. The means of performing these operations will be described in their order.

The feeding apparatus consists, mainly, of two rollers D and D' . They revolve continuously and are connected by two equal spur-wheels G^2 and G^3 upon their shafts near the lower journals. The upper one is fixed in its position. The lower one may approach or recede from it, and when they are so near as to embrace the rod it is fed into the machine. When farther apart their action upon the rod ceases. The bearings of the upper shaft are fixed on projections L' and L' , cast or attached to the frame. Those of the lower shaft are in a movable frame $D^2 D^2$, which has its center of motion on the shaft k . The other end of this frame is attached to and receives its motion from the short arm of the cutting-lever $A A A$, Plates I, II, and V. The connection is made by means of an arm extending from one to the other through the frame, with shoulders on the inside and screws with nuts $p p$ on the outside. A slot y' is made in the frame of sufficient length to allow the motion of the arm, and also a hole o^5 for the passage of the rod. The bevel-wheels D^7 and D^6 , with teeth in the proportion of one to two, communicate motion to the feeding-rolls from the shaft k .

To cut off the rod a stationary cutter g , Figure 7 and Plate V, is attached by a screw-bolt to a projection on the inside of the frame in such a position that the rod slides over it on its passage

H. Burden,

www.libtool.com.cn

Horseshoe Machine,

N^o 17,665.

Patented June 30, 1857.

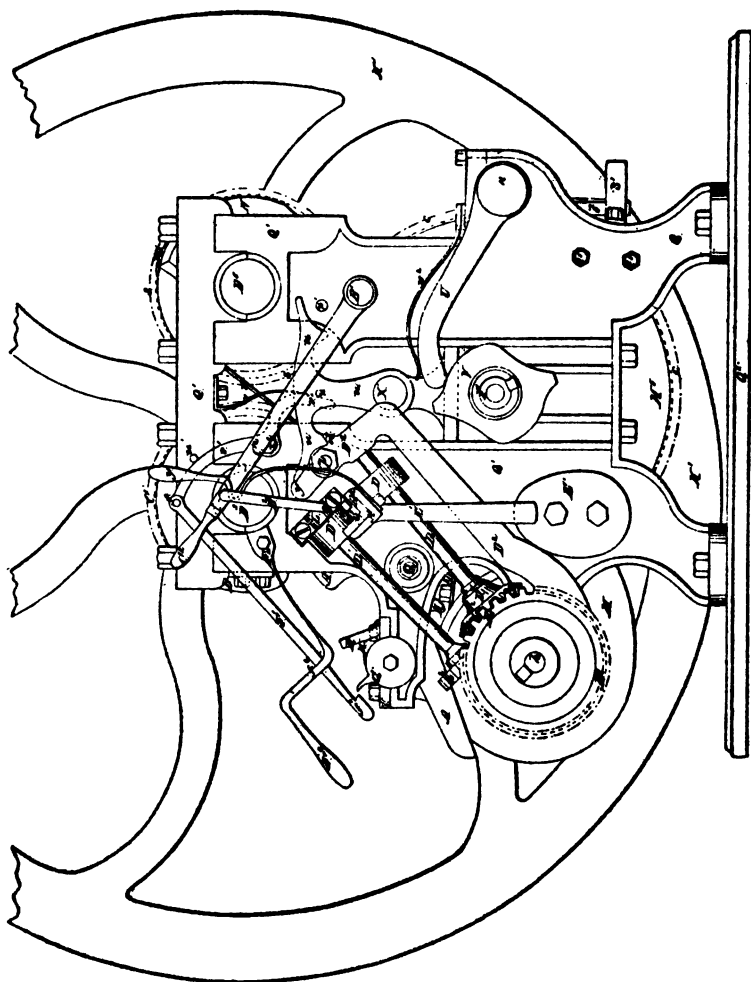

Side Elevation

Inventor,
H. Burden

www.libtool.com.cn

to the machine. The movable cutter g' is affixed by a screw-bolt to the cutting-lever A , which has its fulcrum at Q , attached to the inside of the frame. Its long arm rests upon the cam P , which revolves with the shaft k , and when raised thereby the upper cutter is brought down upon the rod and cuts it off. At the same time the lower feeding-roll recedes from the upper and suspends the feeding action. A spring w aids the weight of the arm to raise the cutter after the rod has been cut off, and to recommence the feeding action by pressing the lower feeding-roll against the rod.

Connected with the feeding apparatus are both a self-acting device to stop its action when a portion of the rod remains too short to form a perfect shoe, and also a means to commence the feeding at the right time with reference to the other machinery when a new rod is to be fed into the machine. To effect the former object is, first, the catch $u u u$. (Fully shown in Plate II.) It moves easily upon its center X , and in a perpendicular position its two arms balance each other. When it is inclined to the right and rests upon its stopping-pin x' , it has no effect upon the feeding-rolls; but when it is inclined to the left, as represented in the drawings, it catches the projection d on the movable frame D^2 and holds the upper cutter down and the feeding-rolls apart. An indicator B^2 , attached to the arm C^2 , that moves easily on its bearing B' , slides upon the heated rod as it passes under it into the machine. Its distance from the feeding-rolls is just equal to the length of rod required to form a shoe, and when less than that quantity passes from it to the rolls it slides over the end of the rod, and drops down through a hole in the feeding-trough, and at the same time a pin P' , Plate I, projecting from the arm C^2 , strikes against the catch and inclines it into a position to prevent the further action of the feeding-rolls. The feeding action will recommence on disengaging the catch; but it is manifest that this must be done during the time that the cam P would hold the feeding-rolls apart, otherwise a portion of the rod would be fed into the machine less than enough to make a perfect shoe and injury might result to the machinery, and as the unlocking at the

right moment, when the machinery is in rapid motion, could not safely be entrusted to the attendant, it is necessary that it should be done by the machine itself, and for this purpose there is provided the lever v' , having its fulcrum at s^2 on the side of the machine. Its lower arm when moved presses against the pin (dotted x) on the catch and forces it back. A spring v holds it forward and against the stop s' to prevent any interference with the catch when not required. At the end of the other arm is attached the connecting-rod F' by a joint at f . It has a notch at f' , which, when caught by the projection G' in the rocking shaft J (the motions of which are at the right time for this purpose), moves the lever v' and unlocks the catch. The lower end of the connecting-rod is supported by a loop f^2 on the side of the spring-handle F^2 , which holds it out of contact with the projection G' , unless the handle is pressed down by the operator. When a new rod is to be fed into the machine, the attendant raises the indicator until it is caught and held up by the spring y . He takes the scrap from the machine and moves the rod up against the cutter. Then the indicator is let down upon it, and placing his hand upon the handle F^2 holds it down to the stop R until at the proper moment the projection G' , catching into the notch f' , unlocks the feeding-rolls, and then action recommences.

The means of bending the portion of the rod that forms the shoe, which are next to be described, are most fully represented in Plates I and IV and Fig. 8, Plate V. The rod when it is fed into the machine passes into the movable guides or holders $I^2 I^2$ against the stop O^2 and in front of the bending-tongue E , and when it is cut off they hold it in its place. These guides are fully represented in Plate I, supporting the rod on three sides. There is one on each side of the large roll H^5 , and these are placed on movable standards $H^2 H^2$, for purposes hereinafter mentioned. Immediately after the rod is cut off the bending-tongue E , having a small projecting edge in front, as shown by the dotted lines in Plate I, to prevent the rod from slipping, moves up against the center of the rod and carries it forward between the holders until it is bent round the tongue into the

H. Burden.

www.libtool.com.cn

Horseshoe Machine,

N^o 17,665.

Patented June 30, 1857

Side Elevation.

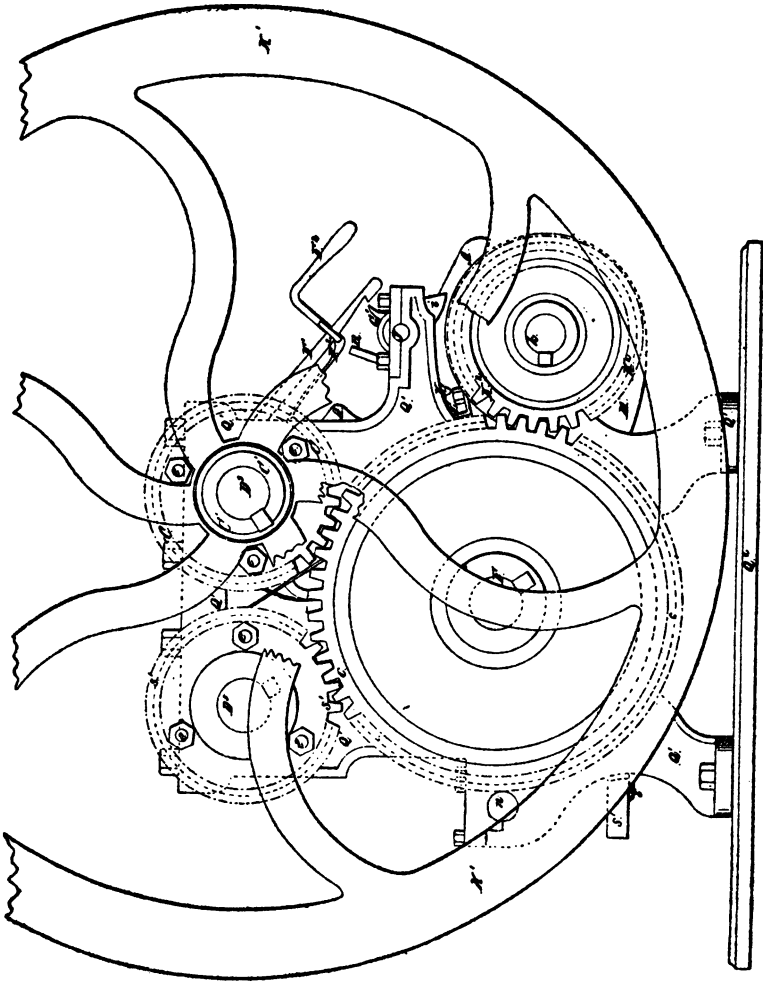

Inventor
Henry Burden

www.libtool.com.cn

H. Burden,
www.libtool.com.cn
Horseshoe Machine,

N^o. 17,665.

Patented June. 30. 1857.

Vertical Section of B. B. Plate A

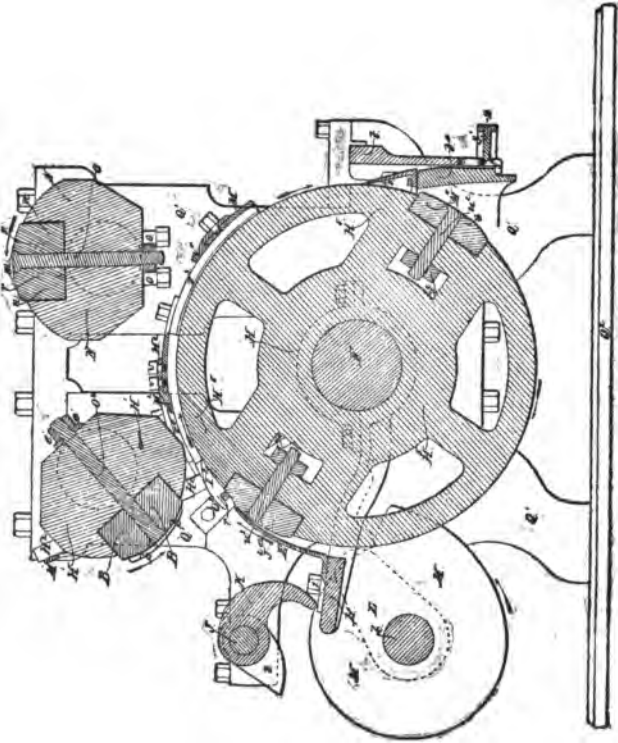

Inventor,
Henry Burden
Co.

www.libtool.com.cn

H. Burden,

www.libtool.com.cn
Horseshoe Machine,

No. 17,665.

Patented June 30, 1857.

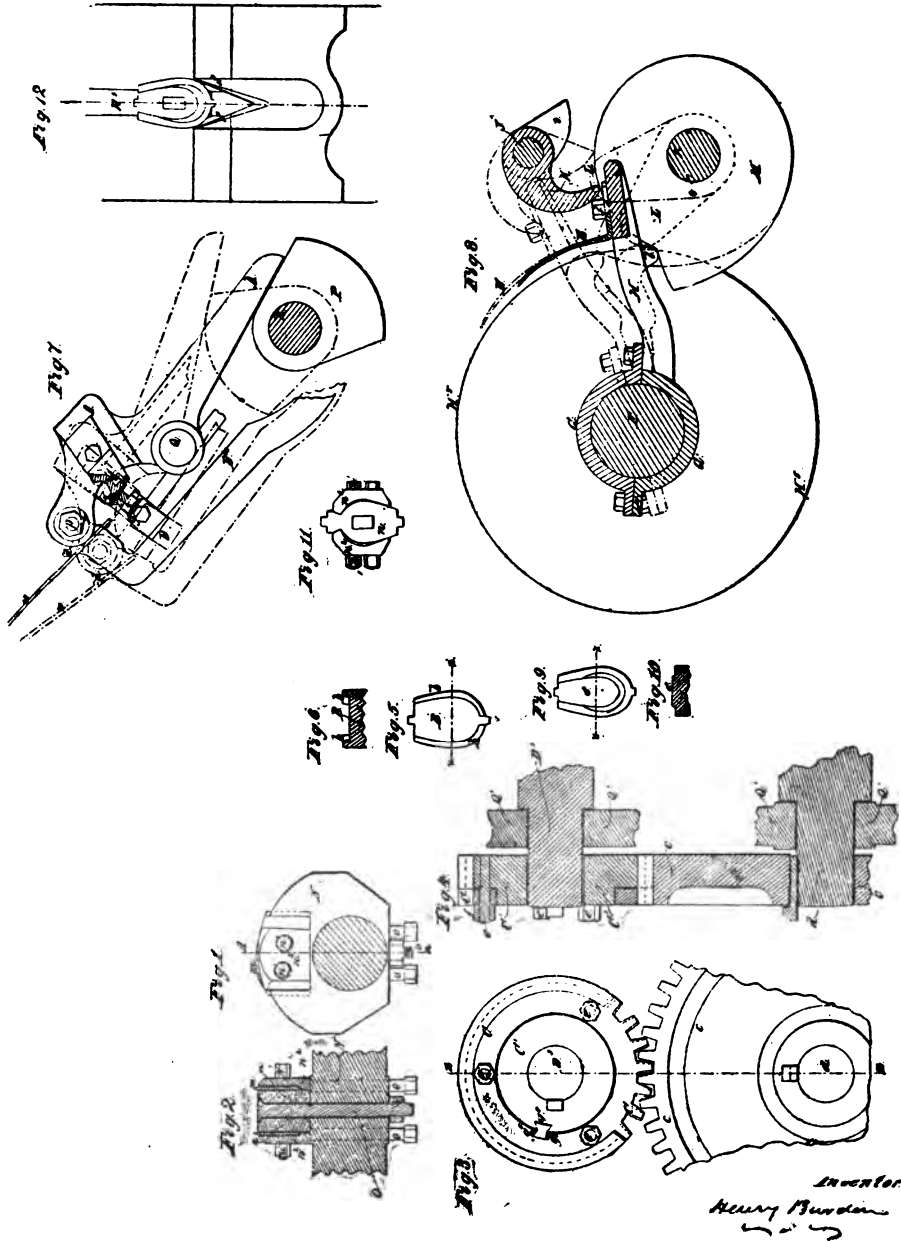

Inventor
Henry Burden

www.libtool.com.cn

desired shape. The frame H, to which the tongue is attached by screw-bolts, has two legs, one on each side of the great roll H⁵, terminating in rings fitted to move on the shaft F. Its motion forward is given by two cams M and M in the shaft *k*, which bears against the small cams *l* and *l* in the frame. To insure its backward motion, an arm K, proceeding from the rocking shaft J and resting on the frame H, is raised by it until the bending-tongue has attained its proper height, when the cam L on the shaft *k* strikes against the other arm *i*, projecting from the shaft J, and forces down the frame and bending-tongue. On the periphery of the large roll H⁵ are two swaging-dies J² and M⁴, placed opposite to each other. Their surfaces are fitted to impress upon the upper side of the horseshoe the precise form which it is desired to give it. It is shown in Figs. 9 and 10 on Plate V. The central portion *e*, the sides of which give shape to the inner edge of the shoe, is elevated above the rest as much as the thickness of the shoe. The surface of the upper swaging-die B B is fitted to make the plane even surface of the under side of the shoe, and as the inner edge is properly made thinner than the outside the natural tendency of the swaging process is to force the rod out from under the swages. This has heretofore constituted one of the greatest obstacles to the forming of shoes by means of revolving dies, and, so far as I have known, it has never before my invention been overcome. I have entirely removed the difficulty by making upon the upper die a flange *b b*, projecting downward to nearly the thickness of the shoe, and, except at the toe, embraces it entirely on the outside. The tendency to straighten is thus entirely prevented and a smooth and perfect surface given to the outer edge of the shoe. It is best represented in Figs. 5 and 6, Plate V. The cams M M are so formed that the forward motion of the bending-tongue commences when the portion of the lower die, which forms the toe of the shoe, comes in contact with or is opposite to its point. It then moves forward with the die as if it formed a part of it, and the rod when bent around is directly over the position at the toe it would occupy on the die. The toe of the shoe is properly made

wider than the sides, and the front of it much thicker than the interior beveled edge, and to allow the iron at the toe to be spread inward for that purpose immediately after the toe of the shoe has been caught between the swaging-dies the bending-tongue is drawn back out of the way. At the same time the two cams S S on the shaft N' are brought in contact with the guides I and I' upon the movable standards H² and H³, and these cause the guides or holders I² and I³ to approach each other and press the ends of the shoe against the elevated central portion of the lower die and within the flange on the upper die. The standards are attached at the bottom by a joint to the arms J' and J', cast upon the inside of the frame. At the top they slide on the cross-piece M'. Another cam e e', Plate IV, moves back the holders to their first position.

Instead of making the swaging-dies upon the surfaces of the rolls H' and H⁵, I make them in separate pieces, as in my former horseshoe-machines, and described in my patents of 1835 and 1843, and attach them to those rolls by bolts and screws. They can thus be readily repaired or "shifted" to make different forms and sizes of shoes. A recess is cast in the periphery of the rolls, as shown by Plate IV. Into this the dies are accurately fitted. Slots or mortises are also made in the rolls, into which the tenons at the ends of the dies (shown in Figs. 5 and 9, Plate V) accurately fit and prevent their lateral displacement. A bolt with a countersunk head passes through the middle of each die and into the roll and fastens it by a screw and nut on the other side. After passing between the dies the shoe is liable to adhere to the upper die, by which great injury may result to the machinery. It is, therefore, indispensable to the practicability of the machine that means should be provided to make the shoe adhere with certainty to the lower die and pass on to be subjected to the next operation.

Two projections v⁴ and v⁵, Plate IV, are cast upon the frame of the machine. To these is attached by screws and bolts an arm M², Plates I and IV, and to this is screwed what I term the "scraper" m². This is made of steel, and its front edge scrapes along the surface of the upper die and separates from it the shoe.

H. Burden,

Sheet 1-3 Sheets

Horseshoe Machine,

N^o 35,746.

Patented July 1, 1852.

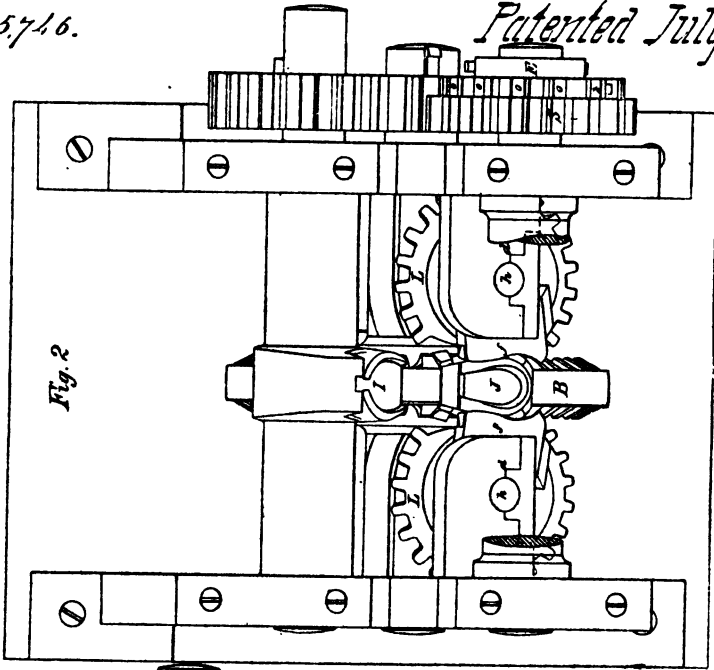

Fig. 2

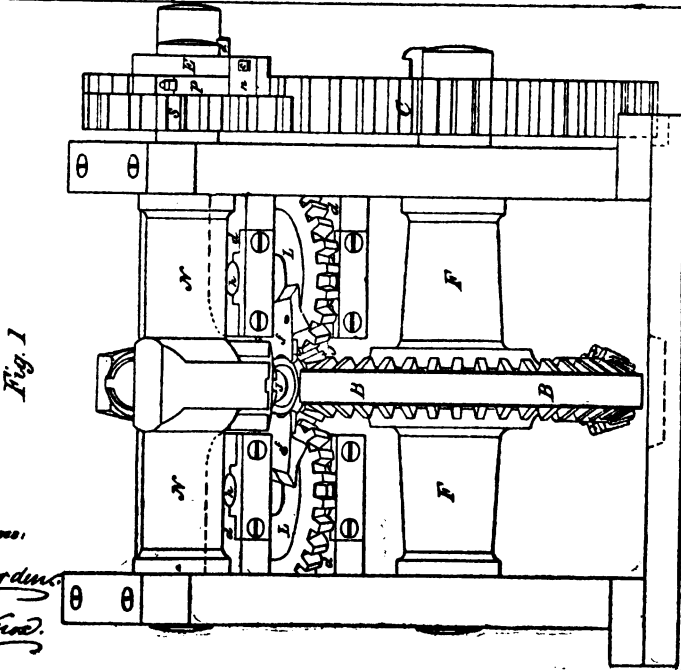

Fig. 1

Witnesses:

H. Burden
J. S. Burden

Inventor:

H. Burden

www.libtool.com.cn

A portion of the flange at the toe is cut away to admit its passage. The elevated portion of the under die passes nearly in contact with its under surface. A similar device takes the shoe from the creasing and punching die. The last-named die, to which the shoe is next subjected, is made in parts, as specified in my said former patents, that the creasers m and m may be replaced or shifted to other sizes and forms. Its construction will be readily seen from Figs. 1, 2, and 11, Plate V. The creasers are firmly held by the clamps u^2 and u^2 on the outside and drawn together by bolts with heads N' on one side and nuts n' and screws on the other. Two adjusting-screws o and o regulate the depth of the creases and holes. It is essential that the upper and lower dies should accurately meet each other in their proper relative positions.

In my former horseshoe-machines adjusting-screws were provided at the ends of the dies; but they did not hold them to their places so firmly and securely as the mode adopted in this machine. Besides, they are liable to be displaced by the wearing of the cogs on the gearing and what is termed "backlash." I have devised a new mode of effecting the adjustment and providing for wearing. The cog-wheels C' and S are made in two sections. Those of the wheel C are represented at C and C' , Figs. 3 and 4, Plate V, and at the same letters on Plate I. The section C is movable on C' , and the two are held together by three bolts e e and e , with heads on one end and screws and nuts on the other. Slots are made for the passage of the bolts through C , so as to admit the requisite motion. A projection g^4 is dovetailed into or cast upon the section C' , and extends into the mortise on section C . Two wedges are fitted into the mortise on each side of the projection g^4 , so that by loosening one and driving the other the relative position of the sections may be changed, and thus the dies adjusted and the backlash prevented. It remains to take the shoe from the lower die, and, as it has the curve of the surface of that die, to flatten it. A brace t^4 , Plate IV, and Fig. 12, Plate V, is placed between the two sides of the frame, to which it is attached by bolts and screws t^5 , Plate II, and helps to support them. A portion of it t^5 is made plain, and the shoe is flattened

by being pressed against it by the flattener t . To the brace are attached two scrapers v^A and v^B , having an edge on the inside of each that scrapes the surface of the lower die, permitting the elevated portion to pass between them. They thus take the shoe from it and conduct it down between the sides of the flattener on to the projection s^2 at its lower end. The flattener is attached to the shaft n , at the end of which is fixed the lever U , pressed by the spring w^2 against the cam V , which, being connected with the shaft F of the big roll, revolves with it and gives to the flattener the requisite motion. A strap S' is attached to the brace to hold the pin x , extending into a slot in t . By the shape of the cam the flattener is first held open sufficient to receive the shoe. Then it closes to flatten the shoe. Then it opens so wide that the pin x pushes the shoe off from the projection s^2 and it drops upon the endless chain to be carried to the storehouse.

The form of the frame Q' , attached to the bed-plate Q^2 , and the arrangement of the gearing are fully shown by the drawings. The machine is driven by a belt on the large flywheel. The wheels S , C' , and K^2 are each one-half the diameter of c and revolve twice, making two shoes to one revolution of the latter.

I am aware that several attempts have been heretofore made to perform that portion of the above-described operations which consist in swaging the shoe by passing it between two revolving dies. The most prominent of these is the device patented to Brazella Young and Samuel Titus in the year 1837; but all these attempts have, I believe, been attended with no practical benefits for the want of those particular means I have above set forth for performing that process. I do not, however, claim the process of passing the shoe between revolving dies generally, but limit myself to the particular devices by which I have rendered it practical.

What I do claim as new, and desire to secure by Letters Patent, is as follows:

1. The above-described feeding apparatus and in connection therewith the mode set forth of cutting off the rod, also the self-acting device for stopping the feeders and the mode of renewing their action at the proper time.

H. Burden,

Horseshoe Machine,

Patented July 1, 1862.

No. 35,746.

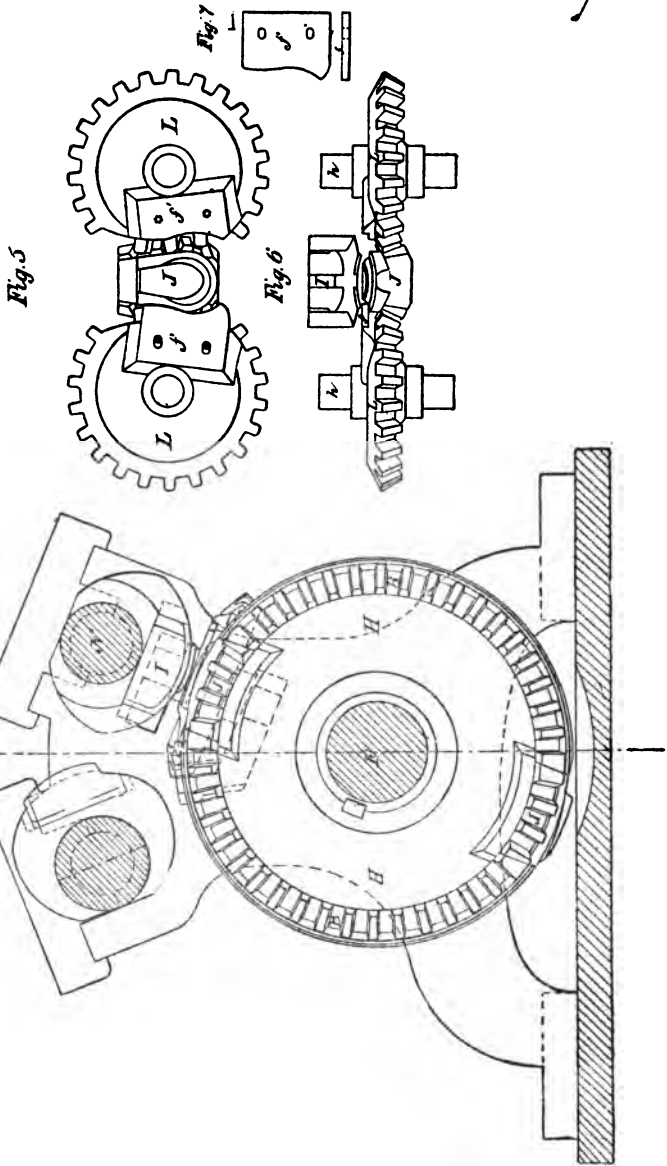

Witnesses:
Wm. J. Burden.
J. S. Burden.

Inventor:
Henry Burden

www.libtool.com.cn

2. The mode of bending the rod and placing it in its proper position between the swaging-dies, as above set forth.

3. The flange on the upper swaging-die, for the uses and purposes specified.

4. The combination of the revolving creasing and punching die with the revolving swaging-dies by which both operations are successively and automatically performed.

5. The devices set forth for taking the shoe from the upper and confining it to the lower dies, and finally taking it from the lower dies and conducting it to the flattener.

6. The means described for flattening the shoe.

7. The combination and arrangement of machinery by which the several processes above described are performed successively by one machine and without aid from attendants.

I do not mean to limit myself to the precise means of performing the operations above set forth, as they evidently admit of several variations; but I claim those devices or their equivalents which shall substantially effect the same purpose.

Witness my hand.

HENRY BURDEN.

Witnesses:

WM. F. BURDEN,

JAMES E. DENNISTOWN.

UNITED STATES PATENT OFFICE.

HENRY BURDEN OF TROY, N. Y.

Improved Machine for Making Horseshoes.

Specification forming part of Letters Patent No. 35,746, dated July 1,
1862

To all whom it may concern:

Be it known that I, HENRY BURDEN, of the city of Troy, in the county of Rensselaer and State of New York, have invented

a new and useful Improvement in Machinery for Making Shoes for Horses, Mules, and other Animals; and I do hereby declare that the following is a full and exact description thereof, reference being had to the annexed drawings.

In the class of machines for making horse and mule shoes that having revolving dies a great difficulty has been experienced in giving a proper shape and finish to the outer edge of the shoe, in consequence of the creaser forcing the iron out of shape and frequently splitting it in the process of creasing and punching, and on this account the crease and holes in shoes could not be made as near to the edge as was desirable.

My improvement consists in a new mode of supporting the outer edge of the shoe during the operation of creasing and punching, by which those difficulties have been removed and a more perfect shoe made than was otherwise practicable.

The drawings represent my improvement as applied to one of the horseshoe-machines for which Letters-Patent were granted to me on the 30th day of June, 1857.

Fig. 1 is an end view of the machine with my improvement applied. Fig. 2 represents it as seen from above with the creasing-shaft removed, the better to exhibit the parts beneath it. The other drawings represent parts to be hereinafter explained.

Upon the sides of the machine are cast projections $d d d$, on which are the bearings of the shaft h and h of the bevel-pinions L and L , and these pinions support and give the proper motions to side-supporting dies $f f$, that support the outer edge of the shoe, as before mentioned. Their axes of motion are in a plane between the centers of the creasing-shaft N and the center shaft F , as shown by the side view, Fig. 3. They gear into and are driven by bevel-teeth cast upon the sides of the lower dies, J and J , and upon segments $B B$, bolted onto the great roll H . The teeth upon the great roll and upon the pinions are in the proportion of two to one, and they are placed on circles (except those portions which bring the side supports into immediate contact with the outer edge of the shoe). There the pinions are curved, as shown in detail in Figs. 5 and 6, and

H. Burden,

Horseshoe Machine.

N^o 35,746.

Patented July, 1, 1862.

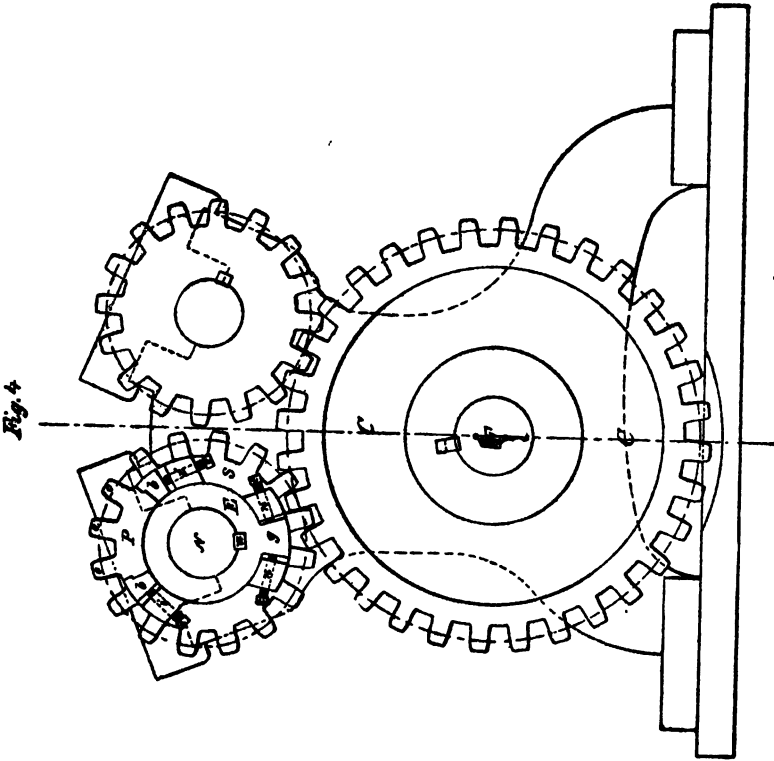
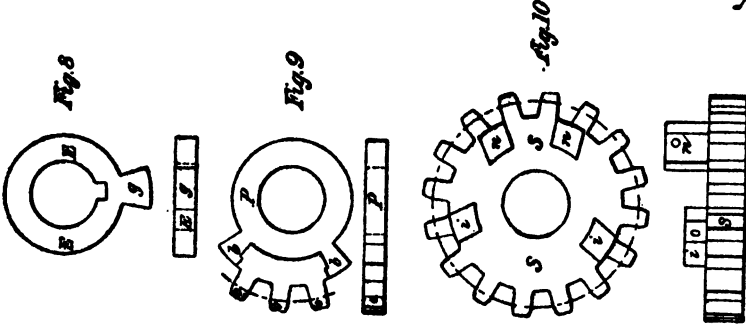

Witnesses:

Henry Burden
Wm. L. Burden

Inventor:

Henry Burden

www.libtool.com.cn

corresponding projections are given to the teeth on the lower dies, J and J. This arrangement produces a varying motion of the side supports and prevents the least bulging or yielding of the outer edge of the shoe, and consequently the metal is prevented from splitting or cracking while the creasing and punching of the shoe are being done, as is herein elsewhere described, the side supports being so contrived and operated as to be constantly in contiguity with the edge of the shoe immediately opposite to the point where the creasing or punching is going on; but they are not intended in any manner to swage or change the form of the shoe, but only to act negatively to prevent any such change on the parts with which they are in contact. One of these side supports is represented separately in Fig. 7, and in its place, attached to the bevel-pinion, in Figs. 5 and 6. They are best made of cast-steel or chilled cast-iron. A suitable place for their reception is cast upon the bevel-pinions, as shown at *f'*. They are attached by screw-bolts passing through oblong holes, by which they are adjusted to their proper places. The faces of the side supports must be adapted to the size and form of the shoe to be made. The most common form is shown in the drawings. It must be such that they shall accurately meet and press against that portion of the outer edge of the shoe which is being creased.

For the purpose of properly and conveniently adjusting the position of the creasers with reference to the lower dies and the side supports, I have devised a method that is represented in Figs. 1, 2, 4, 8, and 10. A ring, E (shown separately in Fig. 8), with a projection or lug, *g*, cast upon it, is attached to the shaft N by the key *a*. The pinion S (shown separately in Fig. 10) moves upon the shaft and has projections *n* and *n* cast upon its side, that extend out on each side of the lug *g*. Set-screws *c* and *c* pass through these projections and bear against the lug *g*, by turning which the position of the pinion on the shaft may be accurately adjusted and the crease brought nearer to or removed farther from the toe of the shoe.

Between the ring E and the pinion S, I usually place another

movable ring, P (shown separately in Fig. 9), with projections *b* and *b* cast upon it and the teeth *o o o*. These teeth and projections are placed between two other projections, *i* and *i*, cast upon the side of the pinion S. Set-screws *e* and *e*, passing through *i* and *i* and bearing against *b* and *b*, serve to adjust the teeth with reference to those of the pinion, so as in effect to increase their width and prevent any backlash or looseness in the gearing at the places where the dies come into operation.

I am aware that four eccentric rolls have been made to act simultaneously upon the four sides of a piece of iron for the purpose of swaging or giving shape to each of those four sides. I do not, therefore, claim, broadly, the use of such rolls acting in that manner for such a purpose.

I am also aware that N. C. Lewis has obtained a patent dated August 7, 1860, for a special arrangement of four eccentrics for forming file-blanks and other like articles, including the shaping of the bars or blanks from which horseshoes are to be formed. I do not use my rolls for drawing out or shaping blanks of any description, but merely for finishing horseshoes which have been previously prepared and bent into the proper shape by other means. My rolls are so arranged and operated that while three of their number merely prevent the iron of the shoe from spreading or yielding, the fourth creases the shoe and punches the holes for the nails, and thus finishes it without any danger of its bulging, cracking, or splitting. My invention is consequently wholly different both in its general purpose and in the mode of its operation from that of the said Lewis, and I, therefore, for the purpose of this application, now disclaim the invention and improvements and all right thereto or any part thereof which are properly secured by the said patent to the said Lewis; but

What I do claim as new, and desire to secure by Letters Patent, is —

1. The peculiar arrangement of four eccentrics operating simultaneously in a machine of this kind by which a horseshoe which has been previously shaped may be punched, creased, and finished without any bulging of the outer surface and without

the danger of the shoe being split or cracked, substantially as above described.

2. Giving a varying motion to the side supports in my said machine, by which I secure a uniformity of motion between the surfaces of those supports and the edges of the shoe with which they respectively come in contact by means which are above substantially set forth.

3. The mode of adjusting the creasers, as above set forth.

HENRY BURDEN.

Witnesses:

WM. F. BURDEN,

JNO. L. G. KNOX.

LETTERS PATENT NO. 1,757.

Sept. 2nd, 1840.

Have invented certain improvements in the machine for manufacturing wrought-iron spikes, by means of which improved machine they are made with hook, or brad-heads, and I thereby declare that the following is a full and exact description thereof:

In my improved machine, the feeding-in of the rod, the cutting it off, and the pointing the spikes are effected in the way previously used by me for performing the same offices in my ordinary spike machines, or adopted by others, and my improvement for forming the spikes with hook or brad-heads may be applied to spike machines of various constructions.

Before the introduction of my improvement, the heads of hook, or brad-headed, spikes were, so far as I am informed, always made by hand, and they were necessarily imperfect, being deficient in that uniformity in shape and strength, which are important requisites. My improvement in manufacturing them consists principally in the employment of what I denominate a bending lever, or some analogous device, by means of which the portion

of the rod which is to constitute the head is bent down so as to form an angle with the shank, and in their forcing up a heading-die, properly formed, so as to upset the bent portion, and to cause it to assume the desired shape.

Having thus fully described the manner in which I, in general, construct my machine for the making of hook, or brad-head spikes, and having given that form thereof which, after numerous experiments, I have deemed to be the best, I will observe that it will be manifest to every competent machinist that considerable variation may be made in the manner of arranging and operating the respective parts, whilst it would remain substantially the same in all its essential characteristics, and I do not intend, therefore, by the foregoing description, to confine or limit myself to the precise form and arrangement of the parts herein shown, but hold myself at liberty to vary them as I may think proper, whilst I attain the same end by analogous means.

What I claim, therefore, in the above-described machine as constituting my invention, and which I desire to secure by Letters Patent, is the bending of that portion of the spike rod from which a hook, or brad-headed spike, is to be formed, by means of which I have denominated the bending lever, or by some analogous device operating substantially in the manner and for the purpose herein set forth; and in combination therewith I also claim the so forming of the heading-die, and of the parts of the gripping-dies within which the bent part is to be upset, as to give the proper shape to the hook or brad-head to be thus formed.

LETTERS PATENT NO. 6,792.

October 16, 1849.

Have invented new and useful improvements in the manufacture of iron and in machinery for producing the same. In the several sections the circles which would be represented by eclipses are drawn in circles.

H. Burden.

Spike Machine.

www.libtool.com.cn

Patented Sept. 2, 1840.

N^o 1,757.

Fig. 3.

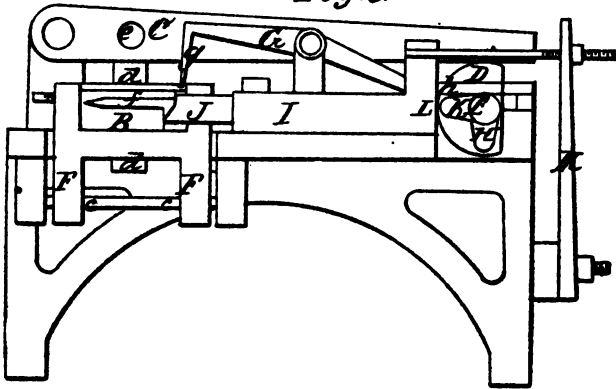

Fig. 2.

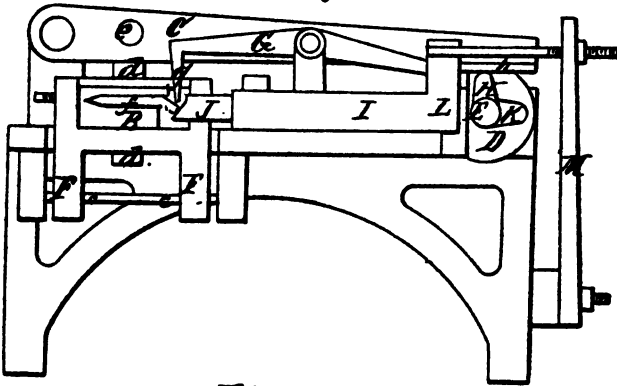
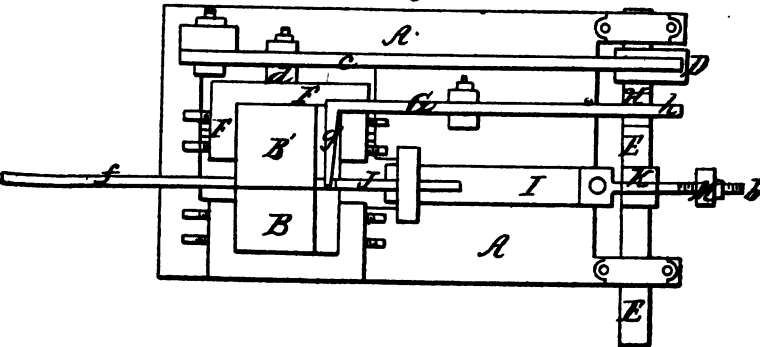

Fig. 1.



www.libtool.com.cn

H. Burden.

Spike Machine.

www.10001.com.cn

Patented Dec. 2, 1834.

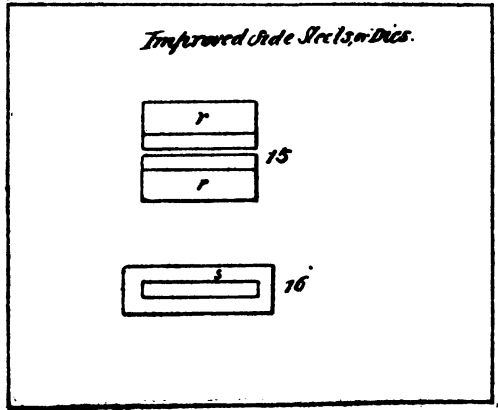
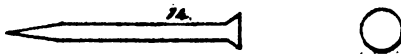
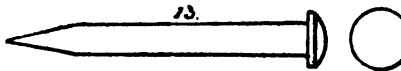
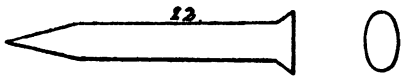
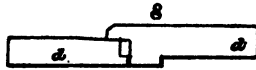
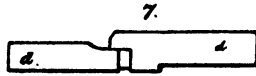
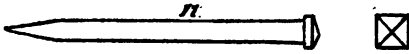
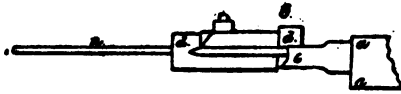
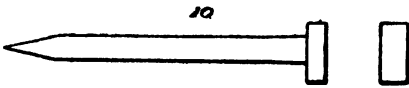
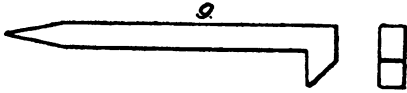

www.libtool.com.cn

H. Burden.

Spite Machine.

www.libtool.com.cn

Patented Dec. 2, 1834.

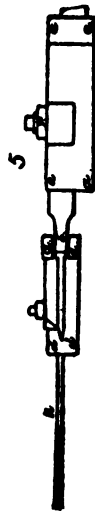
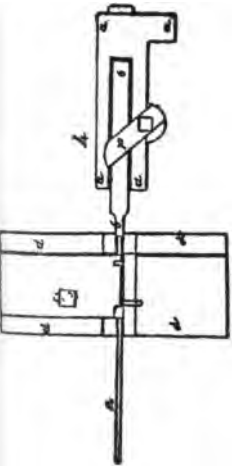
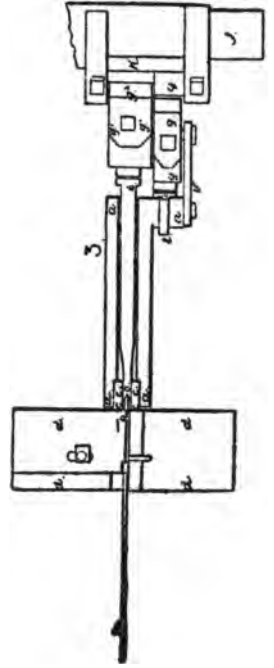
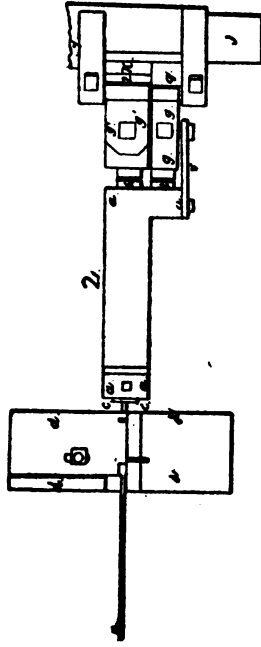
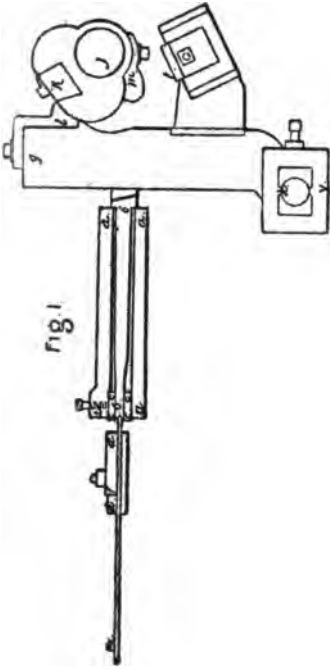

www.libtool.com.cn

H. Burden,

Rolling Puddlers Balls,

www.libtool.com.cn

Patented Oct. 16, 1849.

N^o: 6.792.

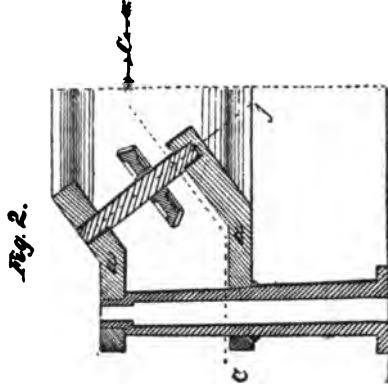
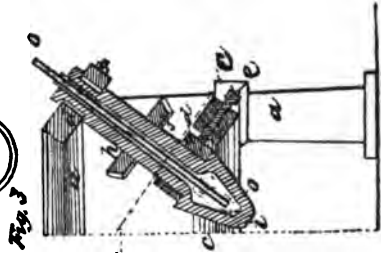
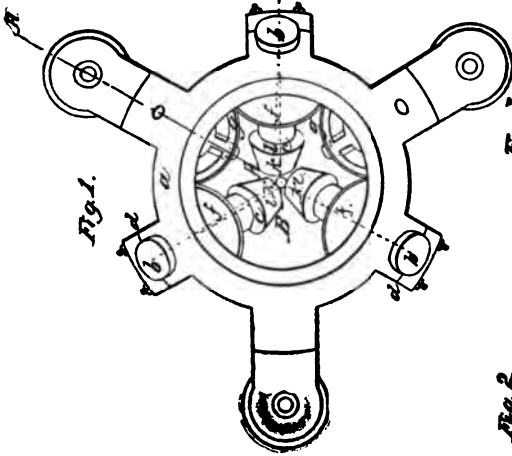
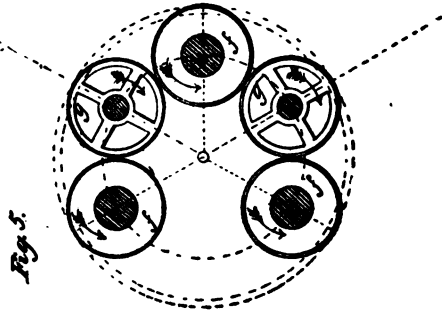
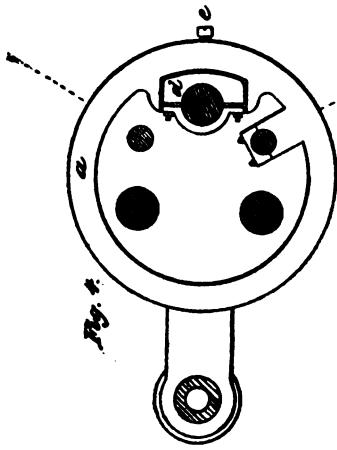
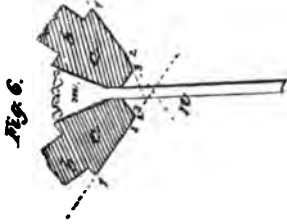

www.libtool.com.cn

N^o 1890.

www.libtool.com.cn

Fig. 1

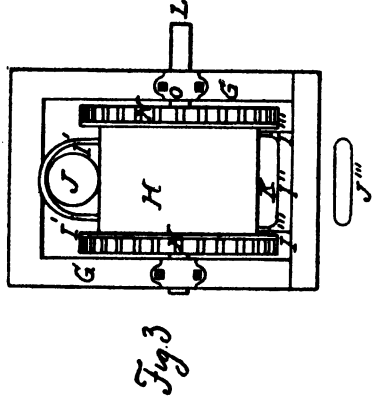
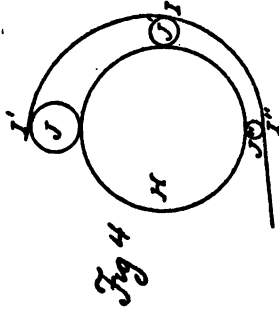
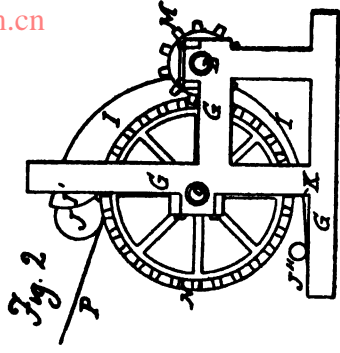
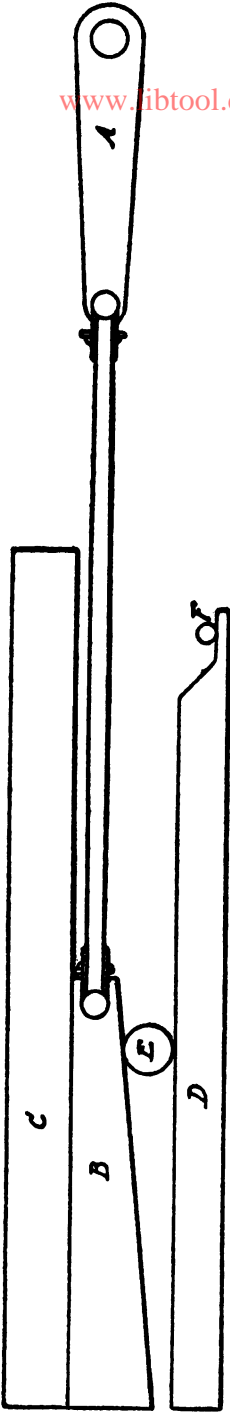

www.libtool.com.cn

The principle or character of my invention which distinguishes it from all other things before known, for the manufacture of iron, consists in working puddle balls, or other highly-heated masses of iron and reducing them into blooms or bars, by rolling and squeezing them from one end toward the other, and by the motion or motions of surfaces at right angles, or nearly so to the axes of the bar or bloom to be produced, whereby the mass is gradually reduced and elongated from one end and the bar produced and finished.

And the principle or character of the machinery which I have invented for the purpose of working iron after my improved method consists in rolling and squeezing lumps or balls of iron between surfaces inclined to the axis of the mass of iron to be worked so that, by the motion of one or more of these squeezing surfaces at right angles or nearly so to the axes of the bar to be produced, the mass of iron shall be thereby gradually squeezed and reduced and carried toward and out of the space between said inclined surfaces where they are nearest together, the mass of iron being there delivered in a finished form. By this means the rolling action on the iron is at right angles or nearly so to the axes of the bar and to the line in which it is elongated, and hence the surfaces which roll or squeeze the metal may be to move much faster than the motion of the mass in the direction of its elongation.

Instead of giving to the axis of the rolls the inclination indicated in Fig. 1, to draw down the iron, this may be effected by making the periphery of the rolls of a cam or eccentric form that when that portion of their circumference or least radius pass by the loop the mass may descend by gravity, or by making thread-like or spiral projections on their peripheries.

Instead of making the lower end of the rolls alone adjustable, both ends may be thus made of the size of the space between their lower ends; may be increased or decreased to determine the diameter of the bar to be produced by sliding the shafts endwise. Instead of giving motion to all the rollers, one or more may be driven to cause the ball or mass of iron under treatment to be rotated and squeezed. And if it be desired to produce a bar of

iron of a tapered form, instead of a cylindrical, during the operation of rolling the mass, the rollers can be caused to recede from or toward each other. And so of the other parts not necessary to be mentioned, but, although the arrangement of machinery within the principle of my invention may be variously modified, I have given a full description and representation of that special arrangement which, on experiment, I have found the most advantageous.

What I claim as my invention and desire to secure by Letters Patent is the method of working puddle balls, or other highly-heated masses of iron and reducing them into bars by rolling and squeezing them gradually from one end and by surfaces whose motion or motions is at right angles, or nearly so, to the axis of the bar to be produced, substantially as herein specified.

And I also claim as my invention in the machinery for the application of my improved method of working iron, the rolling and squeezing of balls or other highly-heated masses of iron between surfaces inclined to the axis of the bar to be produced, substantially as described, so that, by the motion of one or more of the said surfaces at right angles, or nearly so, to the axis of the bar to be produced, the mass of iron shall be gradually squeezed and reduced and carried toward and out of the space between the said inclined surfaces where they are nearest together, the iron bar being thus delivered in the required form, substantially as described.

MR. BURDEN'S HORSESHOE PATENT.

The patent for the invention of the late HENRY BURDEN, of Troy, N. Y., for horse shoe machines, dated June 30, 1857, has been extended by the Commissioner of Patents on proof submitted in the case. It is computed that the invention has saved to the public \$32,800,000 during the past fourteen years. The examiner's report admits the saving of \$18,000,000. The extension is for seven years from June 30.

www.libtool.com.cn

www.libtool.com.cn

www.libtool.com.cn

www.libtool.com.cn

www.libtool.com.cn

www.libtool.com.cn

www.libtool.com.cn

www.libtool.com.cn

This book should be returned to the Library on or before the last date stamped below.

A fine is incurred by retaining it beyond the specified time.

Please return promptly.

MAY 27 1977 H

3324-222

38-2-22
UNIVERSITY OF TORONTO

DEC 29 1972 H

DEC 4 1977

Eng 76.11.5
Henry Burden;
Cabot Science

004496764



3 2044 092 018 258

www.libtool.com.cn