

LANE MEDICAL LIBRARY STANFORD
D245 .D43 1906 STOR
Photography for students of physics and



24503385438

www.libtool.com.cn

www.libtool.com.cn



GIFT
Dr. Horace Gray

AMERICAN BANK NOTE CO. LITHO

www.libtool.com.cn

www.libtool.com.cn

www.libtool.com.cn

PHOTOGRAPHY FOR STUDENTS OF
PHYSICS AND CHEMISTRY

www.libtool.com.cn



www.libtool.com.cn



Mt. Monadnock, N.H. Telephotograph X 10. See page 70.

PHOTOGRAPHY

www.libtool.com.cn

FOR STUDENTS OF PHYSICS
AND CHEMISTRY

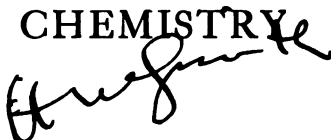

BY

LOUIS DERR, M.A., S.B.

ASSOCIATE PROFESSOR OF PHYSICS IN THE MASSACHUSETTS
INSTITUTE OF TECHNOLOGY



New York

THE MACMILLAN COMPANY

LONDON: MACMILLAN & CO., LTD.

1906

All rights reserved

• • • • •

www.libtool.com.cn

COPYRIGHT, 1906,
BY THE MACMILLAN COMPANY.

Set up and electrotyped. Published November, 1906.

Norwood Press
J. S. Cushing & Co. — Berwick & Smith Co.
Norwood, Mass., U.S.A.

PREFACE

AFTER the acquiring of the necessary skill in manipulation, an inquiry into the nature of a photographic process is the first step in the direction of the systematic experiment which brings such pleasure to the genuine enthusiast and has done so much to advance the science and art of photography. Good handbooks of photographic manipulation are abundant; but as the real business of a handbook is to give directions and not to explain principles, they are apt to be unsatisfactory to the thoughtful worker, interested in reasons as well as results. If he turns to complete treatises, of which there are also not a few, he is likely to find himself overwhelmed with an avalanche of detail and history, with much of which he is not at all concerned, and of no immediate interest or necessity. Neither do monographs offer great help, as a rule, for they are usually highly technical and confined to such limited portions of the photographic field that the desired information generally lies in the gaps between them.

For some years past the author has given annually an elective series of experimental lectures at the Massachusetts Institute of Technology, on the general principles and processes of photography, to students who have studied physics and chemistry, having as a rule some knowledge of photographic manipulation and interested in its scientific aspect as well as its results. The present volume is the outgrowth of these lectures. It is an attempt to present a discussion of photographic processes, so far as their theories may be expressed in elementary form, so

that the photographic worker of ordinary scientific training may obtain a clearer idea of the nature and purpose of his operations. In its preparation it has been difficult to avoid the detail that properly belongs to a handbook or an extended treatise, and still more difficult to resist the temptation to discuss disputed and important points at length; but the endeavor has been made to find a middle ground, not primarily laid out for the tyro who needs to be told that undeveloped plates may not be examined in daylight, nor on the other hand for the skilled investigator who, for example, is seeking data on the spectra of dyes to sensitize his plates for the infra-red spectrum, but rather for the class of photographic workers who take pleasure in the subject for its own sake, who prefer to mix their own solutions rather than to buy them ignorantly in ready-labelled bottles, and who desire to supplement the handbook with something less elaborate than the complete treatise and less technical than the specialized monograph.

In a general work no great claim for originality can be made, except in method of treatment; and in preparing the following pages the standard works on photographic science have been consulted freely. The author desires also to acknowledge the courtesy of the various firms mentioned in the text, for the use of electrotypes of lenses and other apparatus.

L. D.

BOSTON, June, 1906.

CONTENTS.

CHAPTER	PAGE
I. INTRODUCTORY	I
II. PIN-HOLES	4
III. THE LENS	9
IV. ABERRATIONS OF LENSES	24
V. CLASSES OF LENSES. LENS TESTING	55
VI. THE DIAPHRAGM	76
VII. THE CAMERA AND ITS ACCESSORIES	90
VIII. COLOR-SENSITIVENESS OF SILVER SALTS	97
IX. PHOTO-CHEMICAL ACTION	109
X. DEVELOPMENT AND DEVELOPERS	119
XI. MARKINGS UPON THE PLATE	140
XII. FIXING, WASHING, AND DRYING	145
XIII. INTENSIFICATION AND REDUCTION	152
XIV. HALATION AND REVERSAL	170
XV. CERTAIN PRINTING PROCESSES	176
XVI. LANTERN SLIDES	190
XVII. SHUTTER EXPOSURES	210
XVIII. COLOR PHOTOGRAPHY	229
INDEX	245

www.libtool.com.cn

PHOTOGRAPHY FOR STUDENTS OF PHYSICS AND CHEMISTRY

CHAPTER I.

INTRODUCTORY.

PHOTOGRAPHY may be defined as the art of producing fixed images by the action of light. Though this definition in strictness excludes those branches of the art in which the images are only shadows, as in X-ray work, the word *photography* is at present extended to include such pictures, and even to embrace the results produced by almost any agency, if the materials used are those of ordinary photography.

The photographic process has certain limitations, to be described more fully in the following pages; but, apart from these, it differs radically from other modes of pictorial representation, in that the image does not depend on the caprice or talent of the maker, at least so far as the representation of form is concerned. It is also not selective, every impression being recorded as received; so that the impersonality of the photographic record gives it a well-recognized scientific and judicial value that is entirely apart from its mere pictorial possibilities.

The advantages of the photograph in this respect are threefold. In the first place, the absence of the personal element makes possible a complete and unbiased record of the fact, no matter how complex or full of detail it may be.

The camera has no nerves and no uncertain prejudices, and does not suffer from lapse of memory, though its plates may be drugged into paralysis of function. Lacking the painter's power of discrimination between essential and unessential details, it leaves little to the imagination; but though its artistic possibilities are diminished by its impersonal and indiscriminating character, this is the very quality that gives the photograph a high degree of value as a record. In this way it has come to pass that a camera and some knowledge of its possibilities are practically indispensable to the worker in either pure or applied science.

Photography is often called the handmaid of the sciences, and it is at once a faithful servant and a powerful ally. In the work of pure science, every advance is fortified by photographic records, and sometimes begun by them. In engineering and other branches of applied science the camera has assumed a place of rightful importance. It is as well-recognized a part of the equipment of a surveying party, for example, as the transit instrument; and it is common knowledge that there is no important work of constructive engineering that is not photographed in all stages of progress, whether it be bridge, "skyscraper," ship, or tunnel.

The second advantage of the photograph lies in the fact that under suitable conditions impressions can be recorded upon the sensitive plate with great rapidity, and hence it is possible to obtain a knowledge of the separate phases of a movement too rapid for the eye to analyze directly. A familiar illustration of this is the kinoscope film, on which is photographed an immense number of pictures of a moving object, taken in very rapid succession, each picture representing a phase of the motion lasting for only a few thousandths of a

second. Though these films are nearly always employed to reproduce the moving scene, it is obvious that individual pictures may be studied at leisure and made to yield information otherwise quite unobtainable.¹

A third advantage of the photograph arises from the cumulative character of photographic action. Prolonged exposure may give a photographic impression of an object which is much too faintly luminous to be seen directly by the eye. Examples of this effect are seen in photographs of faint stars and other celestial bodies. Many such pictures, obtained by exposures prolonged for hours, show details entirely beyond the visual reach of the most powerful telescopes.

On the other hand, the photographic image has serious limitations. As a record of form, it is tightly bound by the laws of perspective, and it is subject to the conditions imposed by the optical system employed to produce it. The sensitiveness of the photographic plate is far from being in accord with the sensitiveness of the eye, and this may give an entirely false measure of the relative luminosity of different colors. Finally, the translation of the picture into monochrome greatly reduces its brilliancy, and causes the photograph to suffer severely by comparison with either the original or the painter's conception of it.

The definition given above implies three things: a self-luminous or illuminated object, a suitable optical system, and a receiving surface prepared in such a way as to permit the fixation of the image upon it. A study of the subject thus divides itself naturally into the optical problem of obtaining the image, and the chemical problem of giving it the necessary stability.

¹ See MAREY, "Movement," for an elaborate photographic study of the locomotion of persons and animals.

CHAPTER II.

PIN-HOLES.

FOR obtaining a real picture of a luminous object, the simplest optical system is the so-called pin-hole, which is merely a sharp-edged hole in an opaque screen. In Fig. 1, ab represents an object from

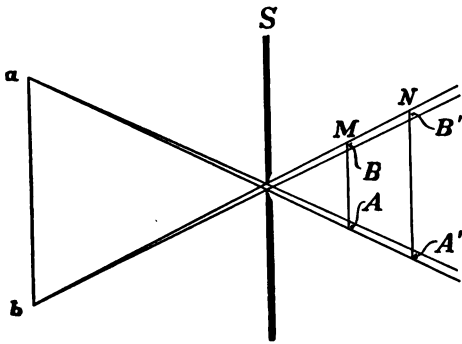

FIG. 1. Formation of Pin-hole Image.

being intercepted by a second screen, placed as at M . It is further clear that the image upon the second screen will not be sharply defined, for the object-point a is represented by the image-area A ; further, this lack of definition will increase as the pin hole is enlarged, though the brightness of the picture will increase in the same ratio. If the hole in the screen is circular, of course the spot A will be circular also if it lies directly opposite the hole, and elliptical elsewhere. The term *circle of confusion* is generally used to denote the image-areas of points, whether produced by pin-holes or lenses.

The pin-hole has one important advantage which may be seen in the figure. If the screen is moved from the position M to N , the circle of confusion A is enlarged to A' ; but as the image is magnified from AB to $A'B'$, in exactly the same ratio, the relative sharpness of the picture remains unaffected. Thus the size of the image may be varied at will, and there is no best position for the receiving screen, so far as distinctness is concerned. But as the image represents the same total of light-energy in every position, the intensity of the illumination over its surface will vary with its area; that is, the brightness of the picture will vary inversely as the square of the distance between pin-hole and image, and the time of exposure necessary for a given result will be directly proportional to the square of this distance. Obviously the illumination will also vary in direct proportion to the area of the hole.

Best Diameter of Pin-Hole. — For the sake of increased sharpness of definition the diameter of the pin hole may be diminished, at the cost of increased length of exposure; but below a certain limit the phenomenon of diffraction causes a loss of definition which more than off-



FIG. 2. Full Size Pin-hole Image of Two Bright Points.

sets the gain. The effect is shown in Fig. 2, which is a pin-hole picture, not enlarged, of two points of light, taken with

a very small pin-hole and a plate at a considerable distance from it. The bright spots representing the image-areas of the points are seen to be surrounded by a series of diffraction rings, which at shorter distances lie so close together as to blend and produce a noticeable blurring of the edge of the image. Similar rings inside the image-circle are visible on the original negative, but are too faint for reproduction. It would therefore appear that there is a certain diameter of hole which will give maximum distinctness, though in order to calculate it, it is first necessary to define distinctness. For pin-hole photography, distinctness is usually defined as the maximum brightness at the center of the image, in which case

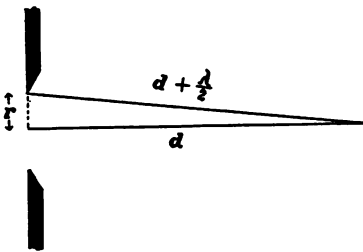

FIG. 3. Condition for Maximum Distinctness of Pin-hole Image.

the best diameter of the hole can be calculated readily.

It is a theorem of physical optics that the maximum concentration of light at the center of the image is obtained when the axial and marginal rays coming through the hole differ in length by one half a wave-length of the

light employed. This condition is outlined in Fig. 3, where the ray coming from the edge of the hole is represented as $\frac{\lambda}{2}$ longer than the central ray d , λ being the wave-length of the incident light. From the figure it follows, if r is the radius of the hole,

$$\begin{aligned} r^2 &= \left(d + \frac{\lambda}{2}\right)^2 - d^2 \\ &= \lambda d, \end{aligned}$$

neglecting $\frac{\lambda^2}{4}$, which is very small.

Therefore, $r = \sqrt{\lambda d}$. (1)

Ordinary photographic plates have their maximum sensitiveness near the blue Fraunhofer line G of the spectrum, for which the wave-length λ is about 0.00017 inch. Hence

$$r = 0.0041 \sqrt{d}. \quad (2)$$

This formula gives the following table:

TABLE I. BEST DIAMETERS OF PIN-HOLES.

DISTANCE BETWEEN PIN-HOLE AND PLATE.	BEST DIAMETER OF HOLE.
3 inches	0.014 inch
4 inches	0.016 inch
5 inches	0.018 inch
6 inches	0.020 inch
8 inches	0.024 inch
10 inches	0.026 inch

In the usual case, however, it makes very little difference whether the image-circle of a point is a spot whose maximum brightness is at its center or whether it is a small bright ring whose edges quickly fade into darkness; and as matter of fact good pictures can be obtained with diameters quite different from those above given. It is easy to make fairly satisfactory pin-hole experiments by removing the lens from an ordinary camera, pasting over the opening a sheet of the thick black paper in which photographic plates are wrapped, and then perforating the paper with a small red-hot needle. A better way of making the pin hole is to take a sheet of thin copper, barely puncture it with a needle point, and then rub off the burred edge on a fine-grained oilstone, keeping the hole clear by occasional reinsertions of the needle. A

moment's contact with the flame of a sulphur match will blacken the edges of the hole, and the result is a sharp-edged pin-hole that will last indefinitely.

Brightness of Pin-hole Image. — Inspection of the foregoing table shows that doubling the distance between pin-hole and plate increases the best diameter of the hole enough to double its area; but as the image covers a quadrupled area at the double distance, it is only half as bright as before, and will require twice the exposure. Since the exposure is rather long at best, this means that work with "long-focus" pin-holes is apt to be unsatisfactory on account of the great length of exposure required. It is interesting to compare directly the brightness of the pin-hole image with that given by a lens. Taking the 6-inch distance as above by way of illustration, the diameter of the hole is $\frac{1}{30}$ of the distance between hole and plate; and, comparing this with a lens working at $\frac{f}{6}$, a diameter fifty times as great, it is easy to see that the lens gives an image 2500 times as bright as the pin-hole, and that therefore the pin-hole will require an exposure 2500 times as long as the lens.

CHAPTER III.

THE LENS.

THE illumination given by the pin-hole is much too feeble for most purposes, and the sharpness of the image leaves much to be desired. It is therefore usually necessary to obtain the image by means of a lens. There is a great gain in both brightness and definition; but a limitation also appears in the fact that the image is now formed in one particular position, and with a given lens its size can be changed only by changing the distance between lens and object.

Anything more than the slenderest outline of the theory of the photographic lens is beyond the scope of this work; but the user of photographic apparatus is often confronted by the necessity of knowing something of the properties and failings of his lenses, without going deeply into the mathematical analysis of the matter; and the following pages have been written with this in view. The lens is by far the most expensive and important single item in the outfit, and the quality of the work done depends primarily upon it.

Axis of a Lens. Equivalent Planes. — Photographic lenses are always made with plane or spherical surfaces. The centers of curvature of these surfaces must lie on a straight line, if the lens is to give equally good definition over its whole field, and this line is called the *axis* of the lens. Not a little of the imperfection in definition attributed to other causes is really due to imperfect adjustment of the lens glasses so that their

centers of curvature do not lie on the axis; but the fault cannot be corrected by the purchaser.

To the mathematician Gauss and his successors is due the application of the formulæ for a simple lens to combinations of lenses, no matter how complex, and the simplification of the entire theory by the help of what are sometimes called *equivalent planes*. These are six planes perpendicular to the axis of the lens, and intersecting it in points that have important properties. Four of these points demand especial attention here.

Nodal Points. — A ray of light, as *ab* in Fig. 4, may enter a lens obliquely in such a way as to emerge without angular

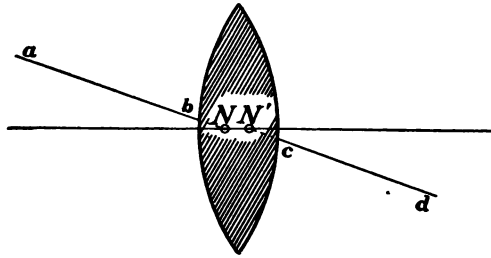

FIG. 4. Nodal Points of a Lens.

deviation, but it will have been shifted sidewise, as shown by the line *cd*. A prolongation of *ab* and *cd* will intersect the axis in the points *N* and *N'*, which are called *nodal points*. They play an important part in the modern theory of lenses. They have among other peculiarities the property which may be expressed in words by saying that a ray entering the lens from any direction toward either of them will emerge from the lens parallel to its original course, but as if it had come directly from the other. This property, therefore, gives a convenient method of ascertaining the final direction of a ray

without tracing its actual path through the components of the lens itself, provided the position of the nodal points is known. The point N is called the nodal point of incidence or admission, the point N' the nodal point of emergence.

In lenses of different types the nodal points vary widely in position. They may coincide or be separated by a considerable interval, or the nodal point of emergence may lie on the

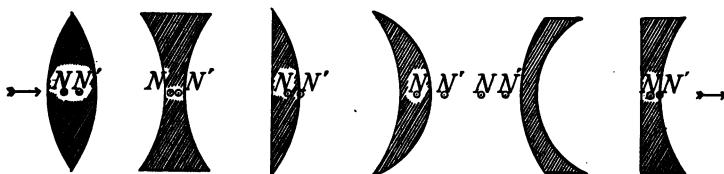

FIG. 5. Position of Nodal Points of Various Simple Lenses.

side toward the incident ray. Figure 5 shows their positions for some simple types of lenses, N being the nodal point of admission and N' of emergence. The light-rays are supposed to pass from left to right in the figure; if their direction is reversed, N and N' simply exchange places. In telephotographic lenses both nodal points are in front of the lens combination, and may be several feet away from the glasses.

Focal Points. — A beam of light made up of parallel rays, sunlight, for example, allowed to shine upon a lens in the direction of its axis, will be refracted more or less perfectly to a point on the axis itself. This is illustrated in Fig. 6. If the lens receives light from a very distant object (the rays from which are practically parallel), the image will be found in a plane perpendicular to the axis at F . This plane is called the focal plane of the lens, the point F the focal point or the principal focus, and the distance f between it and the nodal

point of emergence is called the focal length of the lens. By turning the lens end for end, a second focal point F' may be located in a similar way lying an equal distance f away from the nodal point N . A knowledge of the positions of the

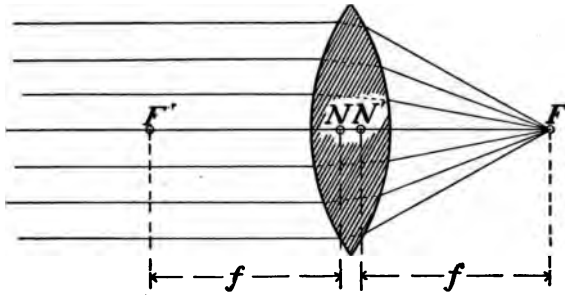

FIG. 6. Focal Points of a Lens.

four points, N , N' , F , and F' , with the planes drawn through them perpendicular to the lens axis, simplifies greatly the analytical study of the lens and lens calculations generally.

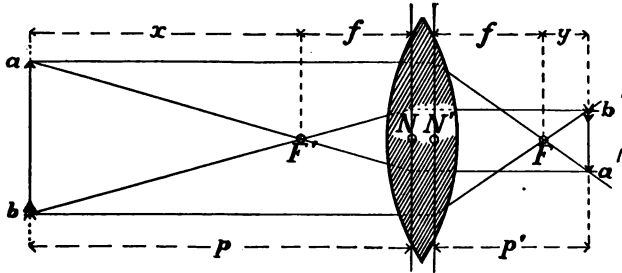

FIG. 7. Formation of an Image by a Lens.

In treatises on optics¹ it is shown that from the positions of the nodal and focal points the position and size of the image $b'a'$ of an object ab may be found as shown in Fig. 7. A ray

¹ VON ROHR, "Theorie und Geschichte der Photographische Optik." GLEICHEN, "Vorlesungen über Photographische Optik."

$$p p' = p f + p' f$$

$$\frac{p p'}{f} = p + p'$$

$$\frac{1}{f} = \frac{1}{p} + \frac{1}{p'}$$

THE LENS

from the point a parallel to the axis of the lens will be refracted as if it had passed through the lens without deviation as far as the plane through the nodal point of emergence N' , and there had been refracted so as to pass straight through the rear focal point F . The actual path through the glass is quite different, of course, but the result is the same as if the course indicated by the dotted line had been followed, the convenience of the method being that nothing need be known or assumed in regard to the actual refraction at the surfaces of the lens. A ray from a which passes through the front focal point F' will be refracted as if it had passed undeviated through to the plane through the nodal point N , and thence parallel to the axis of the lens, meeting the first ray at the point a' . Thus the image of the point a will be found at a' , and by similar reasoning the image of b will be found at b' . Denoting by p the distance between the object and N , the nodal point of incidence, and by p' the distance between N' , the nodal point of emergence, and the image, the similar triangles of the figure give the relation

$$\frac{\text{size of object}}{\text{size of image}} = \frac{p - f}{f} = \frac{f}{p' - f}, \quad (3)$$

which reduces to

$$\frac{1}{p} + \frac{1}{p'} = \frac{1}{f}. \quad (4)$$

a simple and fundamental relation.

From this may be readily deduced another useful proportion :

$$\frac{\text{size of object}}{\text{size of image}} = \frac{p}{p'}. \quad (5)$$

$$\frac{1}{(n+1)f} + \frac{1}{p'} = \frac{1}{f} \quad \parallel \quad p' + \frac{(n+1)f}{n} = p'(n+1) = np' + p'$$

14

When the object is placed n focal lengths in front of F' ,

$$p = (n + 1) f, = nf + f \quad (6)$$

whence, from (4),

$$p' = \frac{n + 1}{n} f; \quad (7)$$

that is,

$$\frac{p'}{p} = \frac{\text{size of image}}{\text{size of object}} = \frac{1}{n}. \quad (8)$$

This gives an important rule for copying, either enlarging or reducing. It may be put into words as follows:

To get a copy $\frac{1}{n}$ the linear size of the original, place the object to be photographed outside the front focal point of the lens and at a distance from it equal to n times the focal length of the lens. The image will then be of the desired size and $\frac{1}{n}$ of the focal length behind the rear focal point. Similarly, to get an image n times as large as the object, set the object $\frac{1}{n}$ of the focal length away from the front focal point; the image will then be found n focal lengths behind the rear focal point.

The focal length and the position of the focal points having been determined once for all, no further measurements for copying than the above need be made, and the most accurate proportions can be obtained without recourse to the too frequent and often tedious process of trial and error.

Measuring the Focal Length. — Figure 7 and the accompanying equations afford a ready explanation of the following simple methods of determining the focal length of a convex lens.

I. With the lens in the camera, focus as accurately as possible upon some very distant object, and mark the position of the lens board on the camera bed. If the camera is of the back-focusing type, in which the lens is fixed and the ground glass the movable portion, the position of the ground glass is to be marked. Next focus on an object placed so near the lens that object and image are of the same size. This measurement is most conveniently and accurately made by cutting a piece, of any convenient size and shape, from the middle of a sheet of opaque paper, and pasting the paper on a window pane to serve as the object. The paper cutting may be held directly against the ground glass as a means of comparing its size with that of the image of the hole. Re-focusing is of course necessary, and a number of trials at different distances may be required. By marking the new position of the lens (or ground glass) on the camera bed, the focal length of the lens is obtainable without further computation, because the elongation of the camera bellows required to obtain the second focus is exactly equal to the focal length of the lens.

II. Although most cameras that are not toys permit the necessary extension, it sometimes happens that the bellows will not stretch sufficiently to make the second adjustment. In such a case it is only necessary to have the image a known fraction of the size of the object, say one half or one third of its linear dimensions. The elongation of the bellows will then be the same fraction of the focal length of the lens, as will appear from the preceding rule for copying. For this purpose the best object to use is a divided scale in a good light. An ordinary foot rule will answer.

III. By substituting $x + f$ for p (Fig. 7) and $f + y$ for p' ,

in equation (4), and reducing, the following relation is obtained:

$$f^2 = xy. \quad (9)$$

This is the basis of another exact method, which, though less simple than the preceding, gives the position of the focal points as well as the focal length. It is as follows:

(a) Reverse the lens in its mount, and focus on a very distant object. Measure along the axis the distance l' (Fig. 8 a), between the image and any convenient part of the lens mounting. This locates the front focal point at F' .

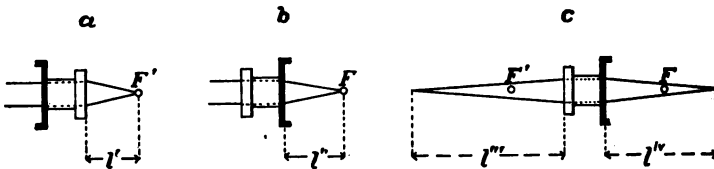

FIG. 8. Measurement of the Focal Length of a Lens.

(b) With the lens in its normal position, focus on the same distant object and measure similarly the distance l'' from the image to any other convenient part of the lens mounting. This locates the rear focal point at F (Fig. 8 b).

Focus on an object several focal lengths (three or four, estimated) in front of the lens hood, and measure, as in Fig. 8 c, the distance l''' from the object to the point used for l' , and l'''' from the image to the point used for l'' .

Then, by equation (9),

$$f^2 = (l''' - l') (l'''' - l'').$$

This method, due to Mr. T. R. Dallmeyer, has the advantage of not requiring any measurement of the image or

any definite ratio between the size of object and image. It can be shown that errors of measurement affect the result least when image and object are of the same size; that is, when l''' and l^{iv} are equal. It is not at all necessary, however, to fulfill this condition exactly in order to obtain accurate results, if the measurements are made with reasonable care.

IV. Approximate Method. — Reference again to Fig. 7 and equation (4) shows that when the object and image are of equal size, the distance between them is four times the focal length of the lens, plus the distance between the nodal points. If the nodal points are inverted or “crossed,” so that N' lies nearer the object than N , this distance is negative. Also, it can be shown, with the help of equation (9), that the distance between object and image is a minimum when $x = y$. This gives the same condition of equality in size of image and object, but as a matter of measurement it is generally easier to adjust for minimum distance than to measure for equal size. It follows that if the distance between N and N' is disregarded, the focal length of the lens can be found by taking one fourth of the minimum distance obtainable between any object and its image. As matter of fact, in most ordinary photographic lenses (except telephotographic combinations) the nodal points are quite close together, and a measurement made in this way will give results good enough for most work, though of course it is not exact.

Finding the Nodal Points. — The nodal points are of interest to the designer rather than the user of a lens, but a method of finding their position may not be without interest. From the fact that the rays leave the lens as if they had come straight from the nodal point of emergence, it follows that if the lens

is rotated slightly about a vertical axis passing through this point, the image will remain stationary. It is therefore only necessary to support the lens in some kind of a V-shaped holder capable of rotating about a vertical axis, and then to slide the lens back and forth in the holder until a position is found by trial where the image of a distant object does not move when the lens is rotated slightly. The aberrations of an imperfectly corrected lens will cause the image to change its position slightly as the lens is rotated, but this displacement is easily distinguishable from that due to motion of the nodal point. When the adjustment is finally made, the nodal point of emergence lies at the intersection of the axis of the holder with the axis of the lens, and by turning the lens end for end the other nodal point can be located in the same way. When the nodal points lie considerably outside the lens the method usually fails, but this is rarely the case except for telephotographic lenses.

One practical application of this principle deserves mention here. In the so-called "panoramic" cameras the lens is rotated to give a picture covering a very wide angle of view, the axis of rotation passing through the nodal point of emergence. The illuminated field therefore travels over the whole area of the plate, but the separate images do not change their position on the plate itself, and there is thus no blurring due to the motion.

Back Focus. — In general, unless the object is very near the lens, the image is only a little way behind the back focal point F (Fig. 7). Hence the distance between the image and the nearest lens glass may be considerably less than the true focal length f , because f is measured from a point which may be several inches farther forward. The term *back focus*

has thus arisen, to denote the distance between the rear glass (or sometimes the edge of the lens mount) and the focal point F . Occasionally, for portrait lenses, back focus has been defined as the distance between the image and the nearest lens glass when the object is at a certain specified distance, thus enabling a purchaser to ascertain the suitability of the particular lens for a given camera.

Equivalent Focus. — In the simpler theory of optics it is customary to study the lens as if it were a single glass, so thin that the distance between its nodal points can be disregarded. Such a lens might conceivably be substituted for any combination, however complex, having the same focal length; hence the origin of the term *equivalent focus*, which means nothing more than the focal length of the simple lens as thus described. Having the same focal length as the complex system, and with its nodal point of emergence in the same place, it would give an image of almost exactly the same size, and its back focus would equal its true focal length. The term *equivalent focus* carries little meaning to lens users who recognize that focal lengths must be measured from the nodal points, though it may be a help to those who insist upon measuring from the surface of the glass.

Focal Length of a Lens System. — The focal length f of a system of two lenses can be calculated when the focal lengths f_1 and f_2 of the components are known, together with the position of the nodal points on the axis of the system. The formula is

$$f = \frac{f_1 f_2}{f_1 + f_2 - d}, \quad (10)$$

where d is the optical interval or separation between the lenses.

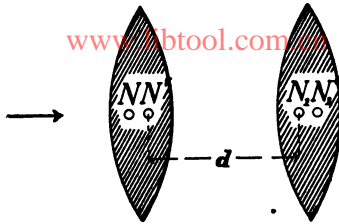

FIG. 9. Optical Interval between Lenses.

As shown in Fig. 9, it is the distance between N' , the nodal point of emergence of the front lens, and N_1 , the nodal point of admission of the rear lens.

Convertible Lenses.—The focal length of a combination thus cannot be calculated

unless the distance d is known. As this is a matter which does not directly concern the user, it is customary for lens makers to supply all three values, f , f_1 , and f_2 , for lenses whose combinations can be used separately. By making f_1 and f_2 unequal, it is thus possible to obtain three different focal lengths with two single lenses, fitted so that either or both can be screwed into the same mounting. This is the principle of the convertible lens.



FIG. 10. Element of Convertible Lens.

Figure 10 shows the construction of a single lens of this kind. Figure 11 and the positive lens of Fig. 45 represent combinations of two such lenses of unequal focal lengths; both lenses are mounted in cells of the same size, so that they may be used interchangeably in the mount, either or both at pleasure. Three, four, or more single lenses, of different focal lengths, may be provided, and the result is the possibility of obtaining combinations covering a wide range of focal

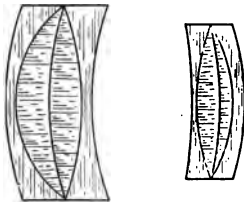

FIG. 11. Convertible Lens with Elements of Unequal Focal Length.

lengths, without excessive cost. Figure 12 shows the actual size of a lens of this character designed to cover a field $5 \times 7\frac{1}{2}$ inches at full opening, with an aperture of $\frac{1}{7}$. The focal length of the front combination is about 14 inches, and that of the rear lens about 11 inches, while the doublet has a focal



FIG. 12. Convertible Lens. Bausch & Lomb Optical Co., Zeiss Patents.

length of 7 inches, thus giving three quite different focal lengths and a corresponding flexibility.

For the convertible lens the maker supplies the value of the focal length of every combination that can be made from the set, not only as a matter of convenience, but because in the different combinations d may be positive, zero, or even negative, thus making it impossible to calculate the focal length of the combination directly from the values for its components.

The variable focus feature is naturally emphasized by makers of such lenses, and is of advantage in permitting a variation in the size of the image without changing the view point; also, by a choice of suitable focal length, the picture may often be given better perspective than could be obtained if the photographer were limited to one lens. On the other hand, the usefulness of the separate lenses of the set is limited, particularly in architectural and interior photography, from restricted points of view, by the fact that in many places the single lens is unsuitable on account of inherent faults to be described in the next chapter.

When several lenses are designed to be used interchangeably in pairs, it is necessary to have each one separately corrected very carefully, and this requires a rather complex construction. Lenses of this type usually have four glasses in each component.

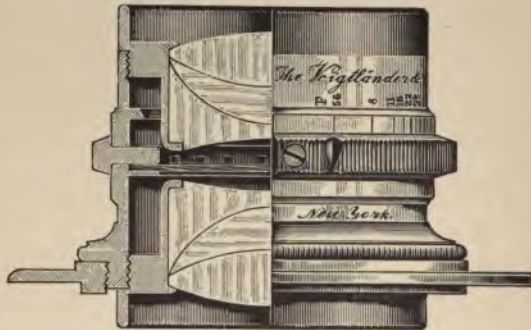

FIG. 13. "Collinear" Lens. Voigtländer & Son Optical Co.

The Symmetrical Lens. — The two parts of a doublet lens may be made alike, in which case the lens is said to be *symmetrical*. Figures 13 and 14 show lenses of this kind.

The nodal points which determine the optical interval d are usually fairly close together in symmetrical lenses, from which it follows that either half of the lens may be used separately as a lens of about twice the focal length of the united pair, and, as will be shown later, about one fourth of its rapidity. This construction is largely used for all classes and grades of lenses. In the lens illustrated in Fig. 13, which was patented in 1894, the complete combination has a rapidity of $\frac{f}{5.6}$ to $\frac{f}{6.3}$, and the separated halves a rapidity of

$$\frac{f}{12} \text{ to } \frac{f}{16}.$$

Another symmetrical lens is illustrated in Fig. 14. The complete lens has an aperture of $\frac{f}{6.8}$, and while listed to cover an angle of 70° will include 90° with small stops. The rear lens, of about twice the focal length of the combination, can be used separately for landscapes.



FIG. 14. Double Anastigmat Lens. C. P. Goerz Optical Works.

CHAPTER IV.

ABERRATIONS OF LENSES.

THE function of the photographic lens is to refract the light rays emanating from an object so as to form a corresponding real image; but it is also possible to state the problem in another way. The acceptance of the wave-theory of light has reduced the term *light ray* to a rather conventional expression, indicating the direction of the motion of the wave-front, rather than attempting to convey any idea that action is concentrated along that line. From this standpoint, then, the function of the lens may be restated as follows: to bring to a single point-focus all the light-waves falling upon it from a corresponding point of the object. This action is

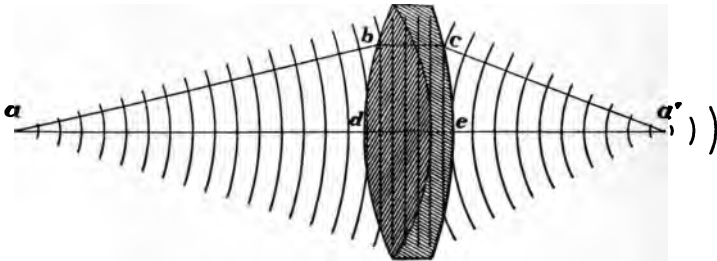

FIG. 15. Action of a Lens upon Light-waves.

illustrated in Fig. 15, where the lens is represented as reversing the curvature of the light-waves falling upon it from the point a , and bringing them to a second center or focus at a' .

A most interesting and important corollary follows from this. In order to attain the desired result the portion of the wave which is traveling in the direction ab must arrive at a' at exactly the same instant as the portion which has started in any other direction, as ad ; that is, the longer path $abca'$ must be traversed in exactly the same time as the shorter one $adea'$. This, of course, requires that the distances bc and de in the glass (through which light travels more slowly than in air) shall be adjusted to produce exactly the right retardation. This adjustment of thickness is accomplished by giving suitable curvatures to the surfaces of the glasses and by proper choice of kinds of glass; but even from this simple statement it can readily be seen that the problem is no easy one. In addition, the photographic lens is asked to perform its function for objects at very unequal distances from it, and to deal with points remote from its axis, as well as to impose no restrictions upon the color — that is, the wave-length — of the light employed. The difficulties of the problem are enormous; and, indeed, the existing state of our knowledge of the subject seems to lead to the conclusion that a perfect point-to-point correspondence between image and object cannot be given by any optical system except the plane mirror, and this, it need hardly be said, is by itself of no value to the photographer. A further difficulty, of much practical importance, may be mentioned. Plane and spherical surfaces are the only ones which can be produced with the necessary accuracy at a reasonable cost. As a practical matter, therefore, the choice of surfaces for lenses is limited to curves of this class, even though in special cases some other form might be desirable.

The actual lens, therefore, falls short of the ideal one, and

may have any or all of a formidable number of faults. Arranged in the following order for convenience, the faults which are liable to appear in photographic lenses are:

- (1) Spherical aberration. Coma.
- (2) Chromatic aberration.
- (3) Curvature of field.
- (4) Astigmatism.
- (5) Distortion.
- (6) Flare spots or ghosts.
- (7) Unequal illumination of field.

Spherical Aberration. — When a beam of light composed of parallel rays falls upon a simple convex lens in the direc-

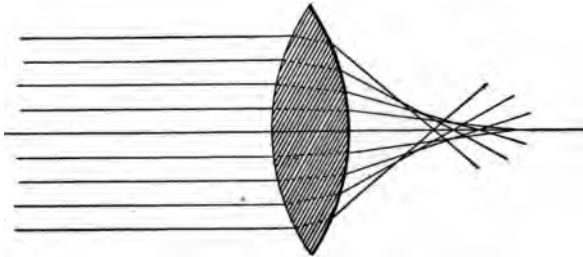

FIG. 16. Spherical Aberration.

tion of its axis, the marginal rays are not only refracted more than the central portions of the beam, as they should be, but are brought to a focus nearer the lens than the focus of the central portion, the zones from the center outward acting like lenses of gradually decreasing focal length. This is shown in Fig. 16. In lenses as they are actually constructed the effect is less pronounced than in the figure, though a lens with the proportions shown would have a distribution of the refracted rays much like the drawing.

The fault is a necessary consequence of the fact that the surfaces of the lens are spherical. Its result can be seen in the figure; no position of the ground glass can be found where the image is sharply defined, every point of the object being represented by a circle whose size depends on the position of the ground glass of the camera. There are a few branches of photography, portraiture, for example, where this is no great disadvantage, unless excessive, for too exact definition in a portrait is neither necessary nor desirable; but to get sharpness of definition it is necessary to reduce the spherical aberration to the lowest practicable limit. It cannot be removed entirely without using surfaces other than spherical, but it can be greatly reduced by choosing suitable curvatures for the component glasses of the lens. It can be still further diminished by a proper choice of the refractive indices of the glasses, though this is generally reserved for making other corrections. Definition is also assisted by placing a diaphragm in such a position along the axis of the lens that only the central rays take part in forming the central portion of the image, and only marginal rays are allowed to form the marginal portions of the image.

For portraiture and other work requiring "soft," (*i.e.*, not sharply defined) effects, it is often

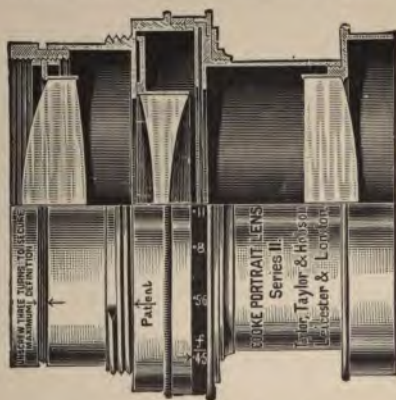

FIG. 17. Lens with Controllable Spherical Aberration. Taylor, Taylor & Hobson, Ltd.

advantageous to be able to introduce at will sufficient spherical aberration to take away the undesirable sharpness of definition. An interesting method of doing this is shown in Fig. 17, which represents a Cooke lens designed for portraiture, in which the spherical aberration may be varied to suit the sharpness or softness of definition required by simply unscrewing the rear lens more or less as marked.

A lens sensibly free from spherical aberration is termed *aplanatic*.

Spherical aberration manifests itself by an uncertainty of definition, and, if considerable, by a difference in the position of the focus according to the size of the stop used. In a given lens it may be studied, sensibly apart from other aberrations, in the following simple way:

Using a stop about one quarter the diameter of the lens, focus on some sharply defined object, as a distant church spire, or better a page of clear print fastened to a near-by wall. As the image will appear sharply defined to the eye over quite a range of motion of the ground glass, it is necessary to use a focusing magnifier of some sort to get the point of best definition as accurately as possible. Then cover the center of the front lens with an opaque disk, about three quarters as large in diameter as the glass. A circle of black paper, dampened with clean water, will stick to the glass for a few minutes and will do no harm to the surface. The light can now pass only through the margin of the outside lens, and an examination of the ground glass will show a decided difference between the image as thus formed and the image formed by the central portion of the lens, unless the corrections have been made unusually well. To recover

good definition it will nearly always be necessary to move the ground glass nearer the lens.

Coma. — Spherical aberration is not confined to the axial beams already illustrated; pencils passing obliquely through the lens also suffer from it, and the fault is then called *coma*. It manifests itself by comet-shaped or pear-shaped blurring of the images of bright points that are not on the axis of the

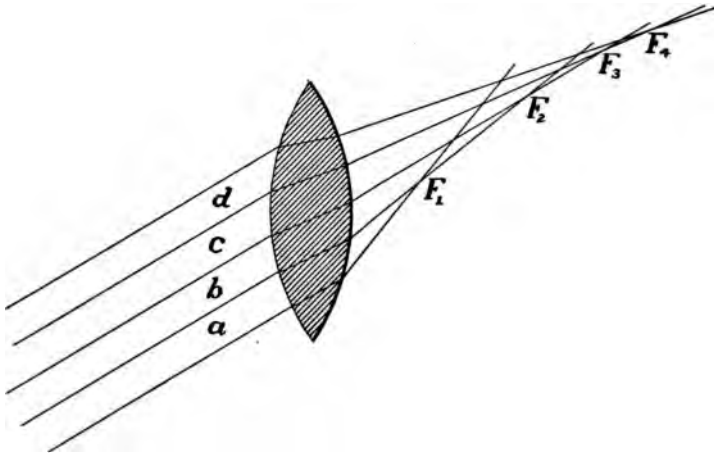

FIG. 18. Coma.

lens. The blurring is not symmetrical about the axis of the beam, and varies with the obliquity, so that the blurred spots will have different shapes on different portions of the plate. A lens having the spherical aberration of a wide pencil corrected is not necessarily corrected for narrower pencils, and this remaining spherical aberration is called *zonal aberration*.

Figure 18 shows the path of the rays through a lens suffering from coma. The different parts of the beam *a*, *b*, *c*, *d*, have their foci at F_1 , F_2 , F_3 , F_4 , respectively, a condition

obviously fatal to good definition. Coma is always accompanied by astigmatism, and a great deal of poor definition is caused by both. A lens may give good definition at the center and corners of a plate, and still possess a perceptible amount of zonal aberration. This may be shown by photographing a large sheet of cross-ruled paper or a newspaper page, when a ring or zone of poor definition will sometimes appear on the plate, though both center and corners may be sharply defined.

Chromatic Aberration. — The dispersive action of a refracting medium on white light has, in the case of a lens, the

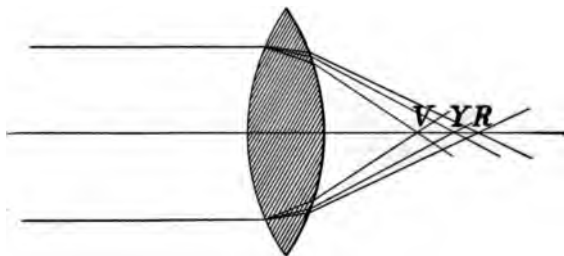

FIG. 19. Chromatic Aberration of a Simple Lens.

effect illustrated in Fig. 19. This is drawn on an exaggerated scale for clearness. When white light passes through a simple lens as shown, the red rays are focused at a point *R*, the violet rays at another point *V*, nearer the lens, and the other spectrum colors at intermediate points. There is thus no single focus for all the spectrum rays, and the image will show a colored border, no matter where the ground glass is placed. As far as mere imperfection of focusing is concerned, the result bears a superficial resemblance to Fig. 16, though the cause is totally different.

The eye is most sensitive to the yellow-green rays of the

spectrum; so that, in focusing, the ground glass is placed somewhere near the point Y . The ordinary photographic plate, however, is only slightly sensitive to these rays, its greatest sensitiveness being in the blue-violet region of the spectrum; hence for a sharply defined photographic image the plate should be placed at or near V . For a lens consisting of a single piece of glass the distance between R and V is about one thirtieth of the focal length of the lens, and between Y and V not much less, so that the difficulty is by no means a trifling one. This difference of focus is particularly noticeable in photography with apparatus like the microscope or ordinary telescope, which are constructed primarily for visual service. No matter how carefully the instrument is adjusted for visual distinctness, it is necessary to find by trial the best position for the photographic plate. Figure 35 (page 54) represents a lens in which the color correction is sacrificed in order to obtain results in other directions compatible with the extraordinary requirements for which the lens is constructed. In using this lens at full opening it is necessary to focus first for visual sharpness, and then to move the ground glass slightly nearer the lens before making the exposure.

From the preceding discussion and the law of the lens, it follows that the simple uncorrected lens shows a twofold chromatic error: first, there is formed a series of images in the respective colors of the spectrum, along the axis of the lens; and second, these images are unequal in size. Hence to get a single image, free from colored edges, it is necessary not only to bring these images together to a common focus, but to make them of the same size, a result which does not necessarily follow from the preceding.

Achromatism.—It is clear that for accurate definition the “visual focus” must coincide with the “chemical focus”; that is, that the images representing the greatest visual and photographic intensity should coincide in both position and size; and this is equivalent to saying that the lens should have refractive power without dispersion. No single known sub-

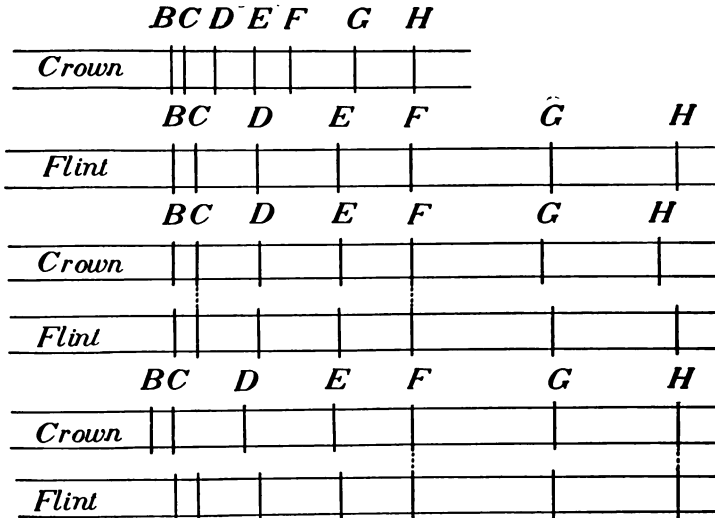

FIG. 20. Visual and Photographic Achromatism.

stance has this property, but approximate solutions of the problem can be made by taking advantage of the fact that different kinds of glass have quite dissimilar refractive and dispersive powers. The method of making the correction may be outlined with the help of Fig. 20, where the dispersion of two kinds of glass is drawn to scale. Instead of using the colors of the spectrum, it is more convenient and more accurate to employ the Fraunhofer lines as identifying marks.

The colors corresponding to the different lines of the visible spectrum are:

A, extreme visible red.

B, red.

C, orange-red.

D, yellow.

E, green.

F, cyan-blue.

G, violet-blue.

H, violet.

If a prism of so-called “crown” glass gives the dispersion shown in the upper spectrum, a similar prism of “flint” glass will give the dispersion shown by the spectrum below it.¹ A measurement of the length of the spectra given by the two prisms will show that the dispersion of the flint prism is about twice as great as that of the crown; hence, to get a dispersion with a flint prism equal to that of a given crown prism, it is only necessary to make the flint prism with a smaller refracting angle — about half as much, when the angles are small. If, then, the two prisms are placed together so that their refracting angles lie opposite each other, the thinner flint prism will neutralize the dispersion of the crown prism within the limits selected, without being able to destroy its refraction, so that the result is refraction of the chosen pair of lines without separation. A prism of this kind is called *achromatic*.

¹Glass is made by fusing silica with one or more metallic bases. When the base is chiefly lead, the product is called *flint glass*, the name coming from the fact that such glass was originally made from powdered flints. *Crown glass* is a more general term given to the finer kinds not containing lead.

The application of this principle to lenses is simple. To neutralize the dispersion of a convex crown-glass lens it is sufficient to place in connection with it a concave lens made of flint glass of suitable curvature. Analysis shows that the focal lengths of the two lenses must be inversely proportional to their dispersive powers. Figure 15 (page 24) illustrates the method of constructing the compound lens; and in this way the focus for the *D*-line, for example, may be brought into coincidence with that of the *G*-line, or any other pair desired may be brought together.

Yet the solution is not a complete one, for the different Fraunhofer lines do not fall in precisely the same relative positions for different kinds of glass. This is called the *irrationality* of dispersion. To get the best correction for visual effects, it is necessary to neutralize the dispersion between the orange and green regions of the spectrum, because the greatest luminosity lies between these limits. The *C*- and *F*-lines are the ones usually chosen for bringing together. But when this is done, as may be seen from the middle pair of spectra in Fig. 20, the *G*- and *H*-lines do not fall together, because of the irrationality just mentioned. Since photographic plates are most sensitive to these rays, it follows that the sharply focused visual image will give a poorly defined photographic picture. For photographic purposes it would be best to bring the *F*- and *H*-lines together, as shown in the lower pair of spectra in Fig. 20; but this throws the visually brilliant *C*- and *D*-region considerably out, and a lens corrected thus for photographic work would give but a poor visual image. The difficulty is a very real one, and in practice is usually met by a compromise. Instead of attempting accurate correction for either visual or photo-

graphic sharpness, the foci for blue and yellow rays are brought together, and the rest left to take care of themselves. The result is that the image shows a narrow fringe of color, to which the name *secondary spectrum* is given. In photography with astronomical telescopes, which are usually corrected for visual achromatism only, the plate must be shifted to the photographic focus, or a color screen is used to cut off the rays except those visually effective, or sometimes a supplementary lens is applied to the object glass itself, thus converting it into a true photographic objective.

Recent improvements in the manufacture of optical glass, particularly by the Jena firm of Schott and Genossen, have made it possible to obtain glasses so perfectly adjusted to each other that a pair can be selected which has an extremely small secondary spectrum, the achromatism being very perfect over a large part of the visible spectrum.

Apochromatic Lenses. — Except for very exact line work and three-color photography, the secondary spectrum is of relatively small importance. It can be reduced to negligible proportions by the use of a third glass, which in general must have peculiar optical properties and chemical composition. In this way three color foci can be brought into coincidence. It has been recently found possible to combine quartz with calcite or fluorite, and to make very fine achromatic lenses from these combinations, but they



FIG. 21. Apochromatic "Collinear" Lens. Voigtländer & Son Optical Co.

are for the microscopist rather than the ordinary photographer.

A lens corrected for three colors is called *apochromatic*. Figure 21 illustrates a lens of this description, made by the Voigtländer firm, and brought out in 1900. The glasses of which it is made are technically known as heavy baryta crown, crown with high dispersion, and borosilicate flint, and the lens is symmetrical.

Simple non-achromatic lenses are sometimes found in cheap cameras provided with focusing scales or having no means of focusing at all. The scale is adjusted to agree as well as possible with the position of the photographic focus, and a ground glass cannot be used. Lenses without chromatic correction have also been advocated for portraiture, where exactness of definition is undesirable. In large sizes such simple lenses should have an immense advantage in cost over other more complex types, but their field of usefulness is of course limited.

Though it is entirely practicable to combine any two desired color foci, there is a fairly general agreement among lens makers upon the choice to give the best results. The following table gives some examples of recent practice. The wave-lengths are given in millionths of a millimeter, and the corresponding Fraunhofer lines are indicated by their letters, the names of a few identifying elements being added for completeness.¹

For three-color work, the lens should be corrected for orange at the Fraunhofer line *C* 656, the orange at the lithium line 610, the green at the Fraunhofer line *b*₁ 517, and the violet Fraunhofer line *g* 423. The particular sensitiveness of gelatine plates lies in the blue-violet region from 460 to 425.

¹ *British Journal of Photography*, March 18, 1904.

TABLE II. COLOR CORRECTIONS OF PHOTOGRAPHIC LENSES.

Steinheil, ordinary lens,	<i>D</i> 589 and <i>g</i> (calcium)	423
Steinheil, astrophotographic,	<i>g</i> 423 and	389
Steinheil, trichromatic,	<i>C</i> 656 and	<i>F</i> 486
Zeiss,	<i>D</i> 589 and <i>G'</i> (mercury)	434
Voigtländer-Harting,	<i>D</i> 589 and	434
Goerz, double anastigmat,	<i>D</i> 589 and	434
Goerz, apochromat,	<i>D</i> 589 and	434
Voigtländer apochromat,	<i>C</i> 656 and	<i>F</i> 486
For chemical rays only, according to Voigtländer,	<i>F</i> 486, 434, and	<i>h</i> 410

In the design of a lens, it is possible to make the correction for chromatic aberration without interfering with that for spherical aberration, because the latter depends on the curvatures of the surfaces of the glasses, and the former on their focal lengths. Since a lens may be made of a given focal length in a great variety of shapes, it follows that the glasses of a compound lens may be made of the requisite focal lengths to correct the chromatic aberration, and of the necessary curvatures to correct the spherical aberration.

Perfect correction for chromatic aberration cannot be made for a lens consisting of a pair of glasses separated by an interval, unless each glass is achromatized separately. Lenses with components thus separately achromatized are shown in Figs. 13 and 14. Without this individual achromatism it is possible to have the colored images of the same size, but in different planes, or all in the same plane and of different sizes; but it is not possible to get coincidence of position and equality of size simultaneously.

Curvature of Field. — Curvature of field is a name given to the fact that the images of points in a plane do not lie

in a corresponding plane, but upon a curved, saucer-shaped surface, usually having its concave side toward the lens, as illustrated in Fig. 22. Placing the ground glass so that the

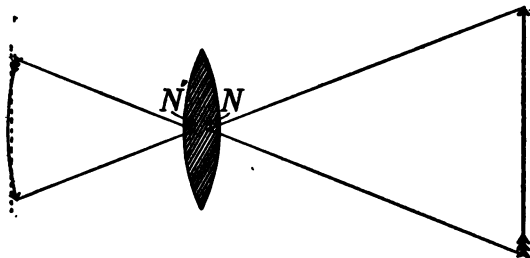

FIG. 22. Curved Field of a Lens.

image is sharply defined in the center makes it blurred at the edges, and adjusting the edges to sharpness blurs the central portions of the image. The fault is particularly noticeable in cheap lenses, and the only way of reducing the blurring is to follow the instructions usually given, to focus on some point halfway between the center and edge of the plate. This, of course, means that the ground glass must be placed as indicated by the dotted line in Fig. 22. In lenses of higher grade the fault is corrected by using a suitable concave lens behind the convex one. The concave lens lengthens the focus of the oblique pencils and thus flattens the field.

Astigmatism. — Astigmatism is usually the primary result of the attempt of the lens designer to produce a lens having a large aperture and a very flat field. A lens suffering from astigmatism will give an image sharp in the center, but rapidly falling off in definition toward the margins, often with a peculiar “streakiness” of definition.

The test for astigmatism is a very simple one. Focus on any sharply defined cruciform object (the bars of a window

are satisfactory) and in the middle of the field both horizontal and vertical bars will be sharply defined. On turning the camera so as to bring the cross near the margin of the plate, as a rule the image must be refocused in order to regain sharpness, owing to the curvature of the field. But it will now be found that either the horizontal or vertical lines are indistinct, and that it is not possible to focus both sharply at once. If a series of concentric circles is employed as the object photographed, the effect is more striking. It is illus-

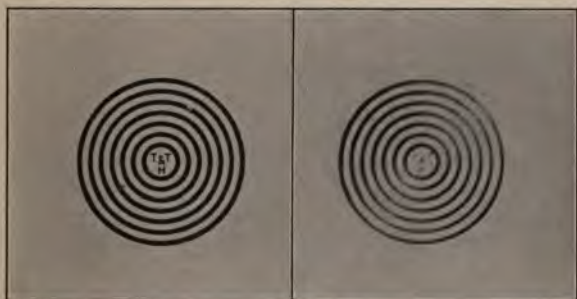

FIG. 23. Effect of Astigmatism.

trated in Fig. 23, which shows the difference between the image formed in the center of the plate and that in the corner, with a lens of good quality.

By refocusing it is possible to bring the horizontal lines into sharp focus, usually by moving the ground glass nearer the lens, but with the loss of distinctness of the vertical lines. Moving the ground glass in the other direction will regain the definition of the vertical lines, but with the loss of the focus of the horizontal set. In intermediate positions neither set will be sharply defined. These effects may be readily seen in daylight by tilting an ordinary reading glass so that the

light from a window passes obliquely through it, and receiving the image of the window bars on a sheet of white paper.

The cause of astigmatism, as this effect is called, is depicted in Fig. 24, in which a beam of light from a point is represented as passing obliquely upward through a lens. To show the effect more clearly a square beam is drawn, though the result is the same whatever the shape of the beam may be. From the figure it will be seen that the rays from the point O do not converge to a point focus, but are focused as two lines, a horizontal line at F_1 and a vertical line at F_2 , farther

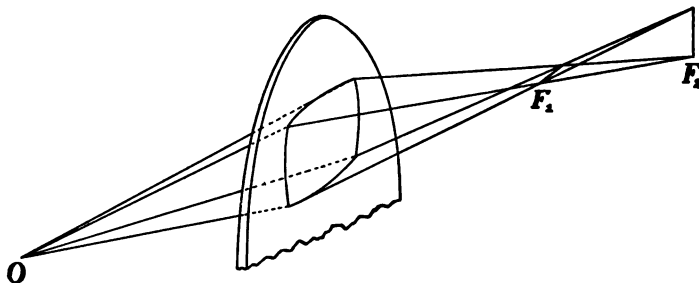

FIG. 24. Cause of Astigmatism.

from the lens. At points between F_1 and F_2 the beam will be spread out over a small area, causing an indistinctness somewhat like that of a pin-hole image, though of course less pronounced. If the point O be replaced by a cross, the horizontal line will be found sharply defined only at F_1 and the vertical line only at F_2 , as may easily be seen by trying the experiment suggested in the preceding paragraph.

The correction for astigmatism is made by choosing suitable refractive indices and focal lengths of the lens glasses; and though difficult, it is possible to make it without destroying the corrections for spherical and chromatic aberration.

A lens having these three corrections will nearly always have at least three glasses. Cheap lenses are almost invariably strongly astigmatic. Astigmatism is so difficult to eliminate that in most cases it can be detected in the corners of a plate larger than that for which the lens is listed, even though definition is entirely satisfactory over the normal plate. Nearly all high-grade lenses will cover a larger plate than the sizes for which they are listed, but when the maker's conservative rating is exceeded, the user must not expect the same sharpness of definition over the extra surface; nor is the falling off a fault of the lens, which is calculated for certain conditions and cannot properly be held responsible if they are not fulfilled. In fact, Fig. 23 was taken with a high-grade lens, which shows no noticeable astigmatism over its listed area, but which for this purpose was used upon a plate about one third larger each way than that for which it is catalogued.

Distortion. — In the discussion thus far it has been assumed that, whatever the errors of definition, there exists what is termed a *collinear* relation between image and object; that is, that every line of the object is represented in the image by a line of proportionate length and corresponding direction. The phenomenon known as *distortion*, however, shows that this condition is not always realized. When a plano-convex lens is placed with its flat side facing the object, the greater refraction of the oblique rays shortens the image of radial lines disproportionately. Object-points lying remote from the axis will be represented by image-points lying nearer the axis than they should be; with the result, for example, that a square having its center on the axis of the lens will appear with its corners drawn inward, as shown in (a) of Fig. 25. This bulging outward of straight lines is called the *barrel* dis-

tortion. By turning the lens so that its convex side faces the object, the opposite effect will be produced. Radial lines will be unduly lengthened, and the image of the square will have its corners pulled out into the pin-cushion shape shown in (b) of Fig. 25. A diaphragm or stop in front of the lens accentuates the barrel distortion, and when placed behind it increases the pincushion distortion, as may be seen by experimenting with any single lens.

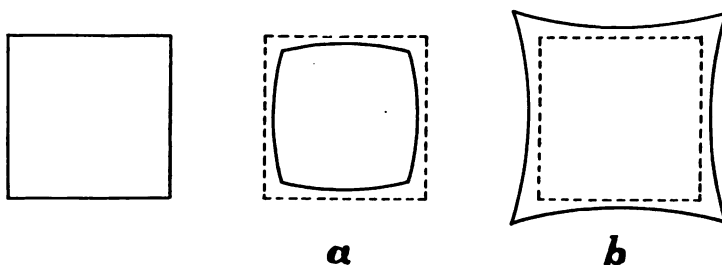

FIG. 25. Distortion produced by a Lens.

Distortion in all single lenses, in some portrait lenses, and in telephotographic lenses, especially at low magnification. The barrel distortion is less displeasing to the eye than the pincushion form, and for this and other reasons mentioned later single lenses should be used with their less curved surfaces toward the object. Single lenses are thus unsuitable for photographing objects possessing long straight lines parallel to the edges of the plate; but by careful designing it is possible to reduce the distortion to a fairly small amount, except at the margins of the field of view; and for landscape and similar work such a lens has many advantages.

Rectilinear Lenses. - Since the character of the distortion produced by a lens depends on the direction of the light through

it, it would seem to be a simple matter to eliminate distortion altogether by placing two lenses in combination, with their corresponding curves facing in opposite directions, and with a diaphragm between them, so that the distortion produced by one lens should be neutralized by the other; and this is in fact the case. Such combinations are called *rectilinear* or *orthoscopic*; and from what precedes it is evident that they must consist of at least two separate elements.

Flare and Flare Spots. — When light falls from air perpendicularly upon a refracting surface, such as the polished face of a lens, it can be shown that the fraction reflected from the surface is given by the expression

$$\left(\frac{n-1}{n+1}\right)^2,$$

where n is the refractive index of the glass. For rays falling obliquely the fraction increases with the angle, and its mathematical expression is more complex. The refractive index of the glasses available for lenses ranges from about 1.49 to about 1.96, averaging perhaps 1.58 for the most commonly used; whence, from the above expression, it can be readily calculated that even under the conditions least favorable for reflection there is a noticeable proportion reflected from each surface.

The importance of this lies in the fact that every ray that is reflected an even number of times must eventually reach the photographic plate. The simplest case is shown in Fig. 26. A part of the light of the rays ab and b' will be reflected back along the directions bc and $b'c'$, and a part of this will be again reflected in the directions cd and d' , finally emerging, coming to a focus at e , and then spreading out over the plate in the circle gh .

The existence of the focus e can be easily shown by the use of a common reading glass and a lamp flame at night or in a darkened room. Besides the principal image at the focus f , there will be found a small and inverted image of the flame corresponding to e , quite near the lens and showing fairly bright upon a sheet of white paper. A single lens has one

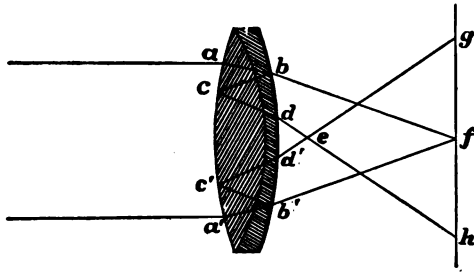

FIG. 26. Flare and Flare Spot.

such image, a lens having two separate combinations (four air-to-glass reflecting surfaces) shows six, a lens with three separate glasses has fifteen, and one with four separate combinations has twenty-eight. In addition to these, which might be termed first-order images, formed by two reflections, others of the second and higher orders can sometimes be detected, formed by four reflections. Referring to Fig. 26, a part of the light reaching the point d is reflected back into the lens, thence to be reflected again at the anterior surface and sent again toward the plate to form a second-order image. The images thus formed by multiple reflection are, however, usually very faint and not easy to see.

The light forming these images by reflection would do no harm if it could be stopped at the focus of each one, unless that focus happened to lie upon the plate itself; but the rays of course continue until they strike the plate, and this stray light produces a general reduction of the brilliancy of the image by covering it with a veil of light that appears as a thin

fog upon the developed plate. This is called *flare*. Any one can examine his own lens for these patches of light by pointing the camera directly at the sun and looking obliquely at the ground glass. If the lens has three or more separated glasses, some of the circles will usually be too faint or too large to be visible; but with a lens having only two combinations, all six are generally seen without trouble. To increase the apparent brightness of the circles, and to avoid cracking the ground glass by the focused heat of the sun, it is well to paste a bit of silvered glass, or even a bit of tinfoil or a coin, on the ground glass at the position of the principal image. With a large lens such as is used for portraiture, and a bright object like the filament of an incandescent electric lamp, the position of a number of the actual images can be found without trouble in a darkened room.

The four accompanying photographs, Figs. 27-30, were taken in the above way, and show some of the reflections produced in lenses of different patterns. Every beam which gets through the lens must at some point of its path have passed through the diaphragm and is limited in size by the diaphragm opening; and the reflections are sometimes called *images* of the diaphragm opening, though they are enlarged copies of it rather than true images. Thus they appear as circles on the plate when the lens has a circular diaphragm, and as regular polygons when the diaphragm is of the iris pattern. In all four pictures the image of the sun is a small bright spot lost in the light of the middle of the plate.

The smaller bright circle of Fig. 27 is the first-order figure formed by two reflections from the glass surfaces of a single lens. The larger circle is the second-order image formed by four reflections.



FIG. 27. Flare in Single Lens.

Figure 28 shows the reflections from the glasses of a lens having four reflecting surfaces. Three of the images are much fainter than the other three.

Figure 29 shows the result of a similar experiment upon a lens having three separate glasses. Fourteen of the circles are visible on the original negative, but not all are sufficiently distinct to be reproduced in the engraving.

There is no way of avoiding these reflections; the utmost the designer can do, after having fixed upon the number of separate elements to be used, is to arrange the position and curvatures of the surfaces so that the reflected light shall be spread out as much as possible over the plate, and not be concentrated into a small area. If this concentration should



FIG. 28. Flare in Doublet Lens.

occur, which is quite often the case with cheap lenses, the resulting bright patch on the plate is called *flare spot* or *ghost*. A flare spot is likely to declare itself unless its diameter is at least six times that of the image of the brightest object in the picture.

The reflected patches of light are of the same intensity, whatever the area of the diaphragm used, while the brightness of the principal image varies directly with the diaphragm area. When the diaphragm opening is changed, therefore, the reflected areas change their size, but not their brightness, while the principal image changes its brightness, but not its size. Thus it follows that ghosts are more likely to appear when small apertures are used. Their position will depend

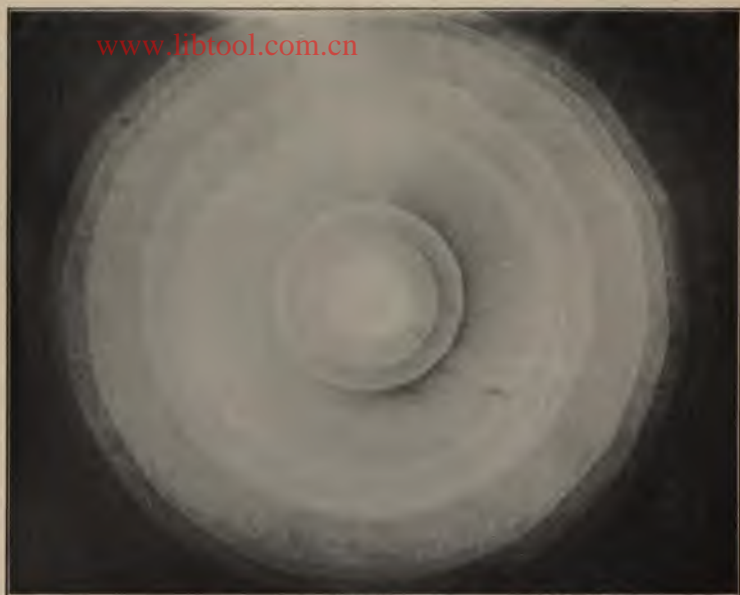

FIG. 29. Flare in Triplet Lens.

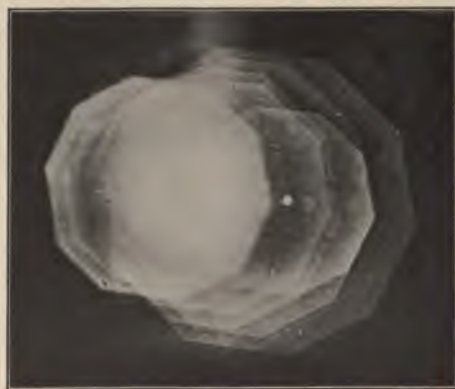

FIG. 30. Smaller Ghosts of a Lens having Four Separate Glasses.

on the obliquity of the incident light, so that if a bright object lies in the field of view but not on the axis of the lens, the ghosts may take the form of circles or parts of circles or polygons, and may appear anywhere on the plate. Figure 30 shows a number of the smaller ghosts of a lens having four separate glasses and an iris diaphragm. The bright light entered the lens with a slight obliquity, and the polygonal figures are therefore not concentric.

Cemented and Uncemented Lenses. — When two lenses of the same curvature are cemented together, there is only a slight change of refractive index at the surface, and therefore but little reflection and no ghosts in consequence. At first sight, therefore, the cemented lens with few separated elements would seem to have a great advantage over other types with more reflecting surfaces, each of which causes a loss of light by reflection as well as a ghost indirectly. This advantage, however, is largely neutralized by the absorption within the glass itself. Optical glass is beautifully transparent and colorless to the eye, but all kinds are not equally so to the rays most affecting the photographic plate, and cemented lenses must be made thicker than uncemented types if their corrections are to be equally good. So what is gained in one place is practically all lost in the other, actual comparison generally failing to show definite superiority for either type, though particular lenses may exhibit differences in this respect.

It was first shown by Petzval in 1840 that the mathematical expressions for the aberrations of a lens system could be reduced to a set of five quantities,¹ which must be separately equal to zero in order to obtain perfect correction. The

¹ LUMMER, "Contributions to Photographic Optics," translated by S. P. Thompson.

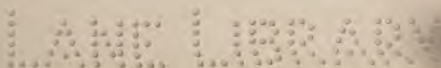

development of these principles indicates that it is theoretically possible to construct a perfectly corrected lens system with only four refracting surfaces; that is, with only two thick glasses. But until glasses of most abnormal optical properties can be produced, this limit appears unattainable. At the present time lenses of fine quality have from three to eight glasses. Theory has been developed well ahead of practice, and the next advance in the construction of lenses must apparently be made in the melting pot of the glass-maker.

Unequal Illumination. — Even when the object is uniformly brilliant, the brightness of the image falls off from center to

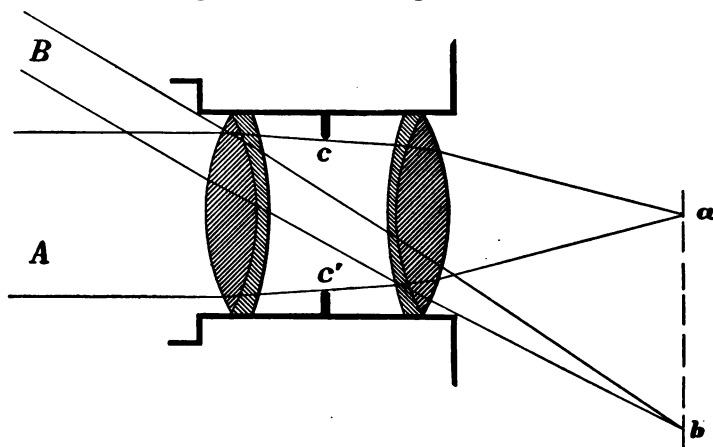

FIG. 31. Reduced Area of Oblique Beam through a Lens.

margin unless the angle of view is very narrow. One reason for this is shown in Fig. 31. The lens mount cuts off a portion of the beam coming from the direction *B*, so that the oblique beam is narrower than the axial beam *A*. This would of course make the image at *b* less bright than that at *a*, other things being equal.

This effect can be somewhat reduced by making the lens as short as possible, and wide-angle lenses are always so made. An illustration of the difference in construction may be seen by comparing Figs. 21 and 34. The former lens is intended to cover angles not exceeding about 50° , the latter for angles of 100° or more.

A second method of reducing the inequality of illumination may be seen at once from Fig. 31. The diaphragm cc' limits the area of the axial beam A , but it may be reduced in diameter considerably before meeting the beam B and cutting off any of the oblique light. By reducing the size of the diaphragm, therefore, the inequality of illumination at the points a and b will be reduced, until the diaphragm begins to cut off both beams, after which there will be no change in the relative brightness of the two foci.

Apart from the above cause of unequal illumination, however, which may be charged to the construction of the lens and which may be reduced very greatly by proper design, there will still be a difference of brightness at the foci a and b , for purely geometrical reasons. It is not difficult to calculate this difference of brightness for a pin-hole, which in this case gives substantially the same results as a lens. At the point E (Fig. 32), the brightness is less than at the point C , in the ratio of the inverse squares of their respective distances from the sources of light A and B . In terms,

$$\frac{\text{brightness at } E}{\text{brightness at } C} = \frac{AC^2}{BE^2} = \frac{GC^2}{GE^2},$$

or in the ratio $\cos^2 \phi : 1$, where ϕ is the angle between the rays AG and BG . The cross section HG of the oblique beam as it passes through the pin-hole is less than the cross section

of the central beam at the same point in the same ratio $\cos \phi : 1$, and this diminution is independent of the one first named. Finally, this doubly diminished quantity does not fall perpendicularly upon the plate as at CD , but at an angle IEF , and is thus compelled to cover an area EF greater than its own cross section in the ratio $EF : EI$, or $1 : \cos \phi$.

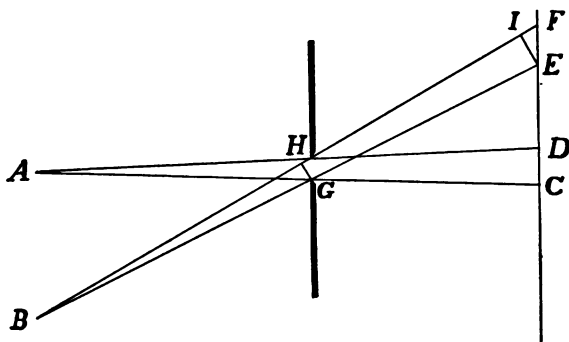

FIG. 32. Axial and Oblique Illumination through Pin Hole.

Thus the illumination over EF will be less brilliant than that over EI , in the ratio $\cos \phi : 1$ again, for this additional reason. Combining all these effects, the result is as follows:

$$\frac{\text{Brightness over } EF}{\text{Brightness over } CD} = \frac{\cos^2 \phi}{1} \times \frac{\cos \phi}{1} \times \frac{\cos \phi}{1} = \cos^4 \phi. \quad (11)$$

In Fig. 33 the value of $\cos^4 \phi$ is plotted for various values of ϕ , the half angle of view included by the lens.

Unequal illumination of the field of the lens is not a fault of the lens considered as a refracting medium, but is a necessary consequence of geometrical principles. For plates not embracing angles of view greater than about 65° , its effect may be neglected, partly because plates as now made permit

considerable variation in exposure without harm to the developed image, and partly because there is usually nothing of importance in the corners of the plate anyway. The diminution begins to show itself when the total angle of view is

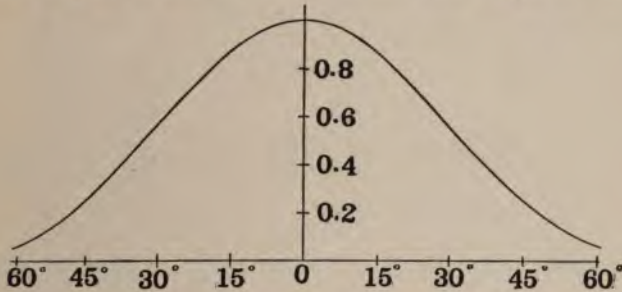

FIG. 33. Values of ϕ and $\cos^4 \phi$.

about 70° , and, as may be seen in the figure, rapidly increases until at 90° or more it is a serious difficulty, aggravated by the effect shown in Fig. 31, so that lenses intended to cover very wide angles must be made extremely short in proportion to their diameters. A good example of this construction is shown in Fig. 34, to which



FIG. 34. Wide-angle Lens (Orthostigmat).
C. A. Steinheil Söhne.

reference has already been made. This compactness of construction is also characteristic of very rapid lenses generally, though the wide-angle lens cannot be made as quick-working as a lens designed for narrow angles only.

With lenses of extreme width of angle the only way of equalizing the illumination is to cut off a part of the light pass-

ing through the center of the lens, by the use of some kind of a diaphragm or its equivalent. One ingenious method of accomplishing the result is shown in Fig. 35. This lens has the extraordinarily wide angle of 135° or more, and in use requires the star-shaped diaphragm shown. About one sixth of the exposure is given with the open lens, and the

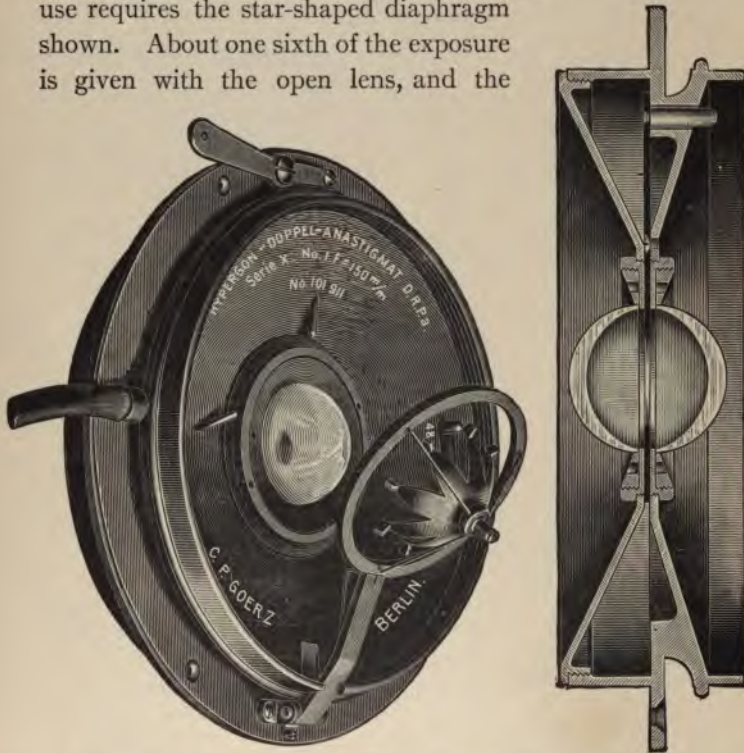

FIG. 35. Wide-angle (Hypergon) Lens. C. P. Goerz Optical Works.

diaphragm is then swung into place and kept rotating during the rest of the exposure. The rotation is managed by an air blast, furnished by a bulb and tube and arranged to blow against the fan-shaped ends of the points of the star.

CHAPTER V.

CLASSES OF LENSES. LENS TESTING.

The Single Lens. — A distinction should be made between a *simple* lens, made of a single piece of glass, and a *single* lens, which may be an elaborate combination of several glasses, cemented together and mounted in a single cell. The former have a very limited field of usefulness because of the aberrations already described, while the latter are of great value for many classes of work.

To reduce the spherical aberration, single lenses are always made in meniscus form; that is, with faces of unequal curvature, one usually concave, the other convex. If the convex side is turned toward the object to be photographed, it will be found that the lens gives a good image of points on or near the axis of the lens, but that the rest of the image is poorly defined. By reversing the lens it will be found that the central definition is not quite as good, but that there is better definition over a much wider area than before; hence such lenses should be used in general with their concave faces turned toward the object. Single lenses are always provided with a diaphragm placed in front of the glass. This serves several useful purposes. By trial it will be found that the nearer the diaphragm is placed to the lens the poorer will be the marginal illumination; while the farther from the glass it is placed the better will be the illumination, the less the spherical aberration, but the worse the distortion. The best

position of the diaphragm is at a distance from the concave surface equal to about one-fifth of the focal length. In this position flatness of field, uniformity of illumination, spherical aberration, and distortion combine to give the best general average of definition.

Besides its comparatively low cost, the great advantage of the single lens is its freedom from flare and annoying flare spots. Its disadvantages are the distortion already mentioned and its comparative lack of rapidity. But for subjects where these are not objectionable the single lens is often to be preferred, because of the more brilliant pictures it will give. Having the lowest possible number of reflecting surfaces, flare is a minimum, and with reasonably careful design no ghost need be feared. For these reasons the single lens is particularly well suited for landscape work, and is indeed often called the "landscape lens." The central portion of the field of a good single lens, where there is no noticeable distortion, often gives quite as good definition as the corresponding area of a more elaborate combination, and not infrequently better pictures for the reasons just given.

Combination Lenses. — It has been shown that a lens must have at least two separated components to be free from distortion. Thus a combination lens may be made rectilinear without difficulty, and this is its first advantage. If the two components are alike, as in the symmetrical lenses already described, one element (the front one, as already shown) may be unscrewed and removed, the rear lens then acting as a single lens of approximately double the focal length of the combination, and therefore giving an image of about twice the former linear dimensions.

The second advantage of the combination lens is rapidity.

The symmetrical pair, for example, has about half the focal length of either component, but is of course of the same diameter and therefore admits just as much light. But because of the halved focal length the image has one-half of the linear size and only one-quarter the area of the image given by the single lenses; hence it is four times as bright, and will need only one-fourth as much exposure with a given size of opening in the diaphragm.

The two parts of a doublet lens may be made dissimilar. A good example of this is shown in Fig. 36. In such cases the separate combinations usually have great individual aberrations, but they are of opposite character in the two parts, so that they neutralize each other. This method permits of very exact corrections without the use of a large number of glasses. In some of the Zeiss lenses, for example, the rear combination can be regarded as correcting the astigmatism of the front lens, and the front lens as correcting the spherical aberration of the rear lens. A lens made of dissimilar combinations is called *unsymmetrical*; its combinations cannot in general be used separately, except with very small stops.

Other Examples of Rapid Combinations. — Within the past ten or fifteen years the production of optical glass with refractive and dispersive powers altogether different from those of glasses previously known has stimulated the manufacture of high-grade lenses to an extraordinary degree, and relegated



FIG. 36. "Protar" Lens. Carl Zeiss.

most of the best of the older types to the ranks of second-quality apparatus. Every effort is made to secure rapidity, particularly in lenses for outdoor work, and present designs



FIG. 37. "Planar" Lens. Carl Zeiss.

Figure 37 represents the Zeiss "Planar," which was patented in 1896. It is of very wide aperture, the various sizes and classes ranging from $\frac{f}{3.6}$ to $\frac{f}{5}$ for the lenses intended for ordinary photography, and $\frac{f}{6.3}$ for the series designed for three-color work. The smaller sizes are much used for photomicrography; also in taking kinoscope pictures, where rapidity is a primary requisite, combined with sharpness of definition sufficient to permit the great enlargement necessary for such pictures.

Figure 38 represents another symmetrical lens, the Goerz double anastigmat, catalogued as Type B, Series 1b, and dating from 1902. These lenses have apertures from $\frac{f}{4.5}$ to $\frac{f}{5.5}$, according to size.

of very rapid lenses are chiefly composed of various arrangements of separated glasses. Figures 12, 13, and 14 are examples of cemented types; the following are illustrations of lenses of the other kind.



FIG. 38. Double Anastigmat. C. P. Goerz Optical Works.

They are of unusually compact build, as may be seen from the drawings.

Still another construction is shown in Fig. 39, which depicts the "Homocentric" lens made by the London firm of Ross, Ltd. This contains four separated meniscus lenses. Besides a rapidity of $\frac{f}{5.6}$, the especial claim for this lens is the removal of all zonal aberration.



FIG. 39. "Homocentric" Lens. Ross, Ltd.



FIG. 40. Cooke Lens. Taylor, Taylor & Hobson, Ltd.

$\frac{f}{6.5}$, according to size. Figure 40 shows the construction.

Another three-component lens with four glasses is shown in Fig. 41. This lens, the Zeiss "Tessar," was patented in 1902. Its compact form and the evenness of

Extremely rapid lenses are also made in unsymmetrical form. The "Cooke" lens, which was produced in 1893, under patents of Mr. H. D. Taylor, has three simple lenses of different glasses and curvatures, separated by unequal air spaces. Two of the components are of crown glass and the third of flint. These lenses range in aperture from $\frac{f}{4.5}$ to



FIG. 41. "Tessar" Lens. Carl Zeiss.

its corrections enable it to be used upon plates considerably larger than those for which it is regularly listed to

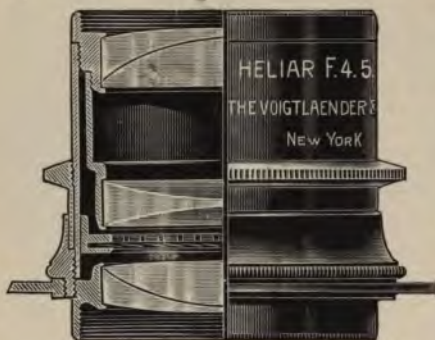

FIG. 42. "Heliar" Lens. Voigtländer & Son Optical Co.

cover. A different three-component construction is employed by the Voigtländer firm, as shown in Fig. 42. Two of the three components are themselves compound, making five glasses in all. The concave lenses are of light silicate flint glass,

the convex of very heavy baryta crown. The series has the rather unusual feature of having the same aperture $\frac{f}{4.5}$ for all sizes listed, whereas in most cases the larger lenses of a series are slightly slower than the small ones. A somewhat similar lens working at

$\frac{f}{6}$ is made by the same firm for hand-camera use. It is illustrated in Fig. 43.

The apparent simplicity of the lenses of the types just described is in part due to the fact that the air space between two glasses is just as truly a lens as the glass itself. The spherical and astigmatic corrections are controlled by adjusting the thickness of the different air lenses,



FIG. 43. "Dynar" Lens. Voigtländer & Son Optical Co.

an operation which must be conducted with the utmost care. The importance of these air lenses is strikingly illustrated

by the "Unofocal" lens, introduced by Dr. C. A. Steinheil in 1903 and illustrated in Fig. 44. This lens has four separated simple lenses, — two convex and two concave. As all have the same focal length and mean refractive index, at first sight it



FIG. 44. "Unofocal" Lens. C. A. Steinheil Söhne.

would seem that such a combination would give no lens effect at all, and this would indeed be true if it were not for the air spaces. The lens has a rapidity of $\frac{f}{4.5}$, and is of great theoretical interest for the following reason:

To get the correction for chromatic aberration, the component convex and concave lenses must have certain relative focal lengths; to get a flat field free from astigmatism another relation between the focal lengths must hold. This is called the *Petzval condition*, and for two lenses is expressed by the equation:

$$\frac{F_1}{F_2} = \frac{n_1}{n_2}, \quad (12)$$

where F and n stand for focal length and refractive index of the respective lenses. There are, therefore, two conditions for the focal lengths to fulfill; and in meeting these requirements other aberrations creep in, necessitating correction in their turn. But by making $F_1 = F_2$ and $n_1 = n_2$, the restriction

imposed by the Petzval condition is removed, and any focus and refractive index may be used, which leaves the lens designer a freer hand to attack the problem of correcting the other aberrations.

Another construction of the above lens is shown in Fig. 44a, where the air-lenses are of proportions quite different from the foregoing. Lenses of this type, with a rapidity of $\frac{f}{6}$, are designed especially for hand-camera use.



FIG. 44a. "Unofocal" Lens. C. A. Steinheil Söhne.

A difficulty which confronts the manufacturer of these unocemented types is that glasses must be chosen from those kinds which are not affected by exposure to the moisture of the air. Some very valuable optical glasses are sufficiently soluble to lose their polish when exposed to atmospheric influences, and such glasses, if used, must be cemented between a pair of hard glasses which are not thus affected.

Lenses with apertures narrower than $\frac{f}{6}$ are made in a great variety of forms, both symmetrical and unsymmetrical. They are less expensive than the very rapid types, and are equally valuable for all purposes except where extreme rapidity is necessary.

The Telephotographic Lens. — Because the focal length of a lens is measured from a point (the nodal point of emergence) which is not necessarily within the lens itself, it is possible to construct lens systems in which the back focus is considerably less than the true focal length. This is the basis upon which the *telephotographic* lens is constructed, and the property of the lens which gives it its great value. A telephotographic combination consists of a convex or “positive” lens behind which is placed a concave or “negative” lens of shorter focal length than that of the positive lens. The lenses are mounted at the opposite ends of a telescoping tube, so that the distance between them may be varied, though it must always be less than the focal length of the positive lens. The positive lens itself may be one made especially for the purpose, or may be an ordinary photographic lens of good quality; the negative lens should be one made for this particular use, and is preferably one adapted to the individual positive lens used. Where great rapidity is desirable, the specially computed positive lens should be chosen; but it is usually not rectilinear, and for general use the less costly combination is preferable, of regular photographic positive lens and telephotographic negative lens. The adjustment of the length of the tube is made by a rack and pinion movement, and serves to vary the focal length of the combination within very wide limits at pleasure.

Figure 45 represents a telephotographic combination of a Zeiss “Protar” lens of the convertible type and a Zeiss telephoto negative in a tube of the same manufacture. The focal length of the combination is about 415 centimeters, and the figure is about half-size.

The theory of the telephotographic lens is too intricate to

be profitably analyzed here; but the analytical expression for the focal length of the combination is readily obtained from equation (10), page 19, noting that one of the focal lengths is negative, since one of the lenses is concave, the other convex. The geometrical representation of its operation can be seen in Fig. 46. In equation (10), for the telephotographic combination, $f_1 - f_2$ will be a rather small quantity, since the focal lengths of the two lenses are not widely different, from which it follows that the

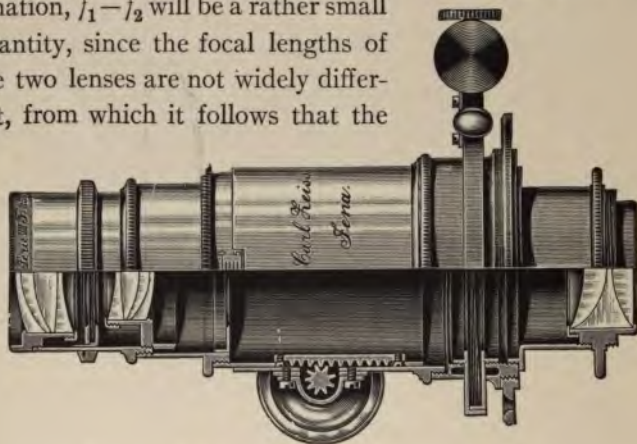

FIG. 45. Telephotographic Combination. Carl Zeiss.

value of d , the distance between the nodal points of the lenses (practically nearly equal to the distance between the diaphragm of the positive lens and the center of the negative lens), controls the value of the denominator of the fraction,

$$\frac{f_1 f_2}{f_1 + f_2 - d},$$

and hence the value of the focal length of the combination. If d is equal to the difference of the focal lengths of the two lenses, the focal length becomes infinite, and the combination

is called *telescopic*. If d is made zero, the focal length of the combination has its minimum value. Thus a single pair of lenses may be used to obtain any desired focal length by the simple turning of a screw, and the image of a given object at a fixed distance can be made to take any size desired if the camera has the necessary extension of its bellows.

But if the only advantage of the telephotographic lens were its elasticity of focal length, it would lose a large part of its actual usefulness, for the long bellows necessary for great focal lengths would always be difficult to manage and sometimes impossible. Figure 46 illustrates the second prop-

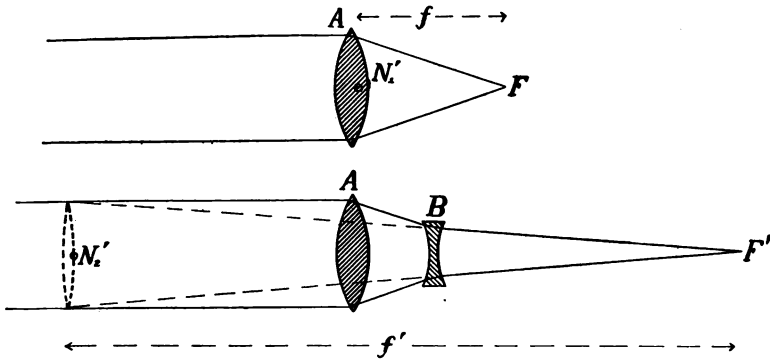

FIG. 46. Principle of Telephotographic Lens.

erty of the telephotographic lens which enables the user to take full advantage of its great focal length without extreme length of bellows. The focal point of the single lens A is at F , a distance f from the nodal point N_1' ; that is, practically, from the middle of the glass. If now a concave lens B is placed behind A and in contact with it, the focal point is moved back to some other position, and the focal length of the

combination correspondingly increased; but the nodal points remain very nearly in their original positions, and the new focal length, measured as before from the middle of the glass, requires a proportionately greater bellows extension. But by placing the concave lens *B* a little way behind *A*, the focal point is not only moved to a position F' , but the nodal point of emergence of the system moves in the opposite direction, taking a position N_2' ; and the image produced by the combination is identical in size with the image that would be given by a single lens with its nodal point of emergence at N_2' and with a focal length equal to f' ; yet the distance of the image from the nearest lens *B* is not materially greater than the original value of f , and the camera extension is therefore kept within moderate limits. By this arrangement, therefore, it is possible to obtain images of much larger proportions with a given camera extension than in any other way. The ratio between the linear dimensions of the image with the combination and with the positive lens alone is called the *magnification*. It is evidently equal to the ratio of the focal lengths of the combination and the positive lens alone.

The following formulæ relating to the telephotographic lens are given without proof. For the complete theory the reader must be referred to larger works.¹

Let f_1 = focal length of positive lens.

f_2 = focal length of negative lens.

f' = focal length of telephotographic combination.

M = magnification, *i.e.*, $\frac{f'}{f_1}$.

¹ CZAPSKI, "Theorie der Optischen Instrumente nach Abbe." 1904.
DALLMEYER, "Telephotography." 1899.

E = camera extension or back focus, *i.e.*, distance from negative lens to plate.

d_1 = effective diameter of positive lens.

d_2 = effective diameter of negative lens.

D = effective diameter of telephotographic combination.

I = diameter of image circle on plate.

Then

$$E = (M - 1)f_2. \quad (13)$$

$$f = \frac{f_1}{f_2}E + f_1, \text{ for distant objects} \quad (14)$$

or $f = Mf_1. \quad (15)$

$$\frac{D}{f} = \frac{1}{M} \times \frac{d_1}{f_1}. \quad (16)$$

$$I = \frac{E}{f_2} \times \frac{d_1 f_2 + d_2 f_1}{f_1 - f_2}, \text{ approximately.} \quad (17)$$

Formula (13) gives the necessary camera extension directly in terms of the magnification and the focal length of the negative lens. It follows from this that high magnification with a moderate stretch of bellows is possible only with a negative lens of short focus. Equation (14) enables one to calculate the focal length of the combination, and hence the magnification, obtainable with a given camera extension, the extension being measured practically from the middle of the negative lens to the ground glass. Equation (15) gives a very simple way of finding the focal length of the combination from the magnification.

Equation (16) is an important one for the user. It shows that the effective diameter of the combination becomes a

smaller and smaller fraction of its focal length as the magnification increases. It will be proved later that the exposure must vary inversely as the square of this ratio, hence for a telephotographic lens the exposure increases as the square of the magnification. Telescoping tubes fitted to particular lenses usually have the magnifications engraved upon them, at the various positions of the sliding tube, and thus enable the user to calculate the exposures mentally without trouble; tubes which are intended to be used with several different lenses cannot be so easily treated, and impose a certain amount of calculation on the user, though this is reduced as much as possible by various ingenious devices.

Equation (17) gives the diameter of the image-circle. It is seen to be directly proportional to the bellows extension, and to depend on the diameters of the lenses as well; the latter would naturally be expected. The diameter of the negative lens, however, is the controlling factor, for as f_1 is larger than f_2 , a variation in the quantity d_2 will make a greater change in the value of the numerator of the fraction than an equal or even proportionate variation in d_1 . Thus the image-circle at low magnifications will be small unless negative lenses of large diameter are used; and to get a large image-circle at low magnification it is more important to have a large negative lens than a large positive lens.

The conclusion concerning exposure, drawn from equation (16), is sometimes doubted by those who think that the exposure should be more nearly proportional to the magnification, ascribing the difference to the effect of atmospheric haze and other conditions. It is not difficult to see why this idea should be put forward. A distant mountain, for example, occupies at most only a small portion of the picture formed by an

ordinary lens, and the exposure is naturally determined with reference to the more prominent portions of the scene, with the result that the image of the mountain is usually over-exposed. A telephotographic view of the mountain alone would have its exposure timed without reference to any other object, and therefore would be given less exposure than the preceding case would require. The higher the magnification the less is included in the angle of view besides the principal object, and the less consideration is necessary for other things.

For photographing distant or inaccessible objects, particularly the picturing of mountain scenery in the clear air of high altitudes, the results made possible by the telephotographic lens are beyond comparison with effects produced in any other way. At first sight it might seem that everything accomplished by the telephotographic lens might be reached more simply by enlarging a small negative taken in the ordinary way; but a single trial will show that the limit of this process is reached in a very few diameters, the loss of detail by enlargement and the grain of the negative itself setting a limit which cannot be exceeded with satisfactory results. The enlarged negative cannot show more than the original; the telephotograph can and does give details which are invisible in the smaller negative, and cannot be brought out by enlargement.

One working difficulty with the telephotographic lens is that the short-focus lens needed for high magnifications has only a small image-circle at low powers. To cover a plate of the usual size at low powers, it is therefore necessary to have a second negative lens, of larger diameter and longer focus. For architectural details and general use the low-power negative lens will usually be found the most serviceable; its

focal length should be about half the focal length of the positive lens. For distant mountains and similar scenes the high-power negative lens is best; its focal length may be one-third of the focal length of the positive lens, or even less. The Frontispiece is a photograph of the latter class. The magnification is ten diameters, *i.e.*, the focal length of the telephotographic combination was ten times the focal length of the positive lens, and the picture therefore ten times the linear size of the small picture in the corner, which represents the view as photographed with the positive lens alone. The focal length of the combination was 8 feet, while the camera extension was only 23 inches. The distance between mountain and camera was 21 miles.

Figure 47 is a low-power telephotograph, magnification four diameters, taken over the roofs of the intervening buildings between the tower and the camera, the distance being about 800 feet. The definition is not quite as good as would be obtained directly by an ordinary lens of the same focal length, but is far better than could be obtained by enlargement. The small picture shows the comparative size of the image, with the positive lens alone, of 13 inches focal length. The Frontispiece and Fig. 47 are reductions from 8×10 originals.

The telephotographic negative lens can be fitted without much trouble or expense to any photographic lens of the ordinary patterns, but satisfactory results cannot be obtained unless the latter is of high quality. The telephotographic combination is both bulky and heavy, and its weight is generally distributed in such a way as to strain the camera front more or less. It is absolutely essential to prevent vibration of the camera during exposure, and the only practicable way

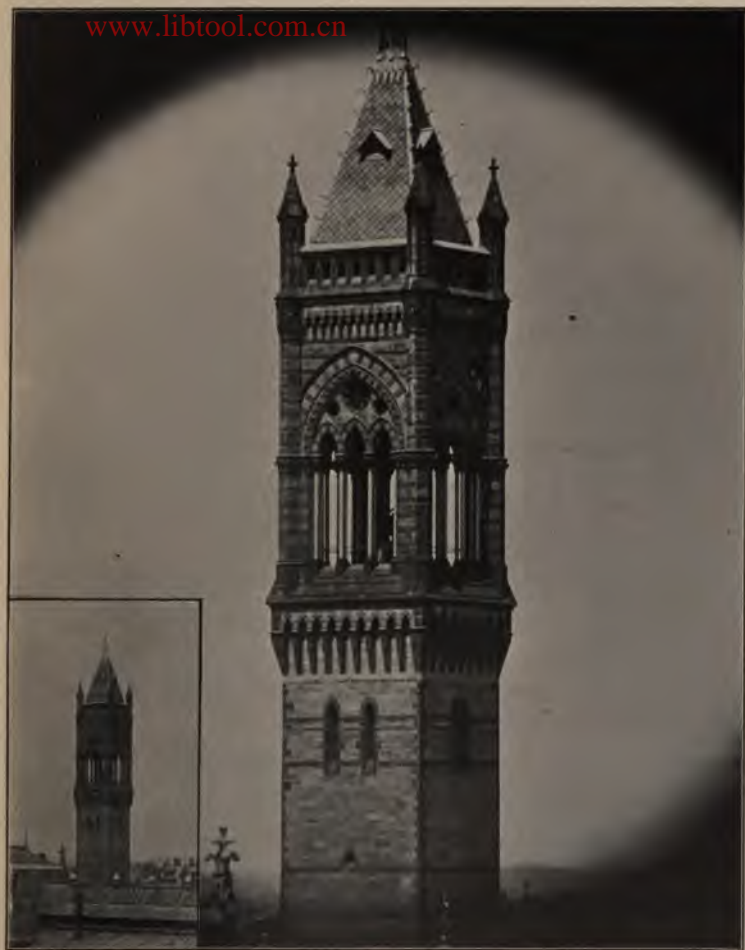

FIG. 47. Telephotograph $\times 4$. Old South Church Tower, Boston.

of doing this in the field is to carry a second tripod, to which the lens must be clamped before the exposure is made. The operation of focusing is less easy than with the ordinary lens, and the general manipulation of lens and camera more difficult, so that telephotography is hardly to be recommended as a pastime for the beginner; but to one who has passed his novitiate it is a fascinating branch of the photographic art.

Lens Testing. — Though it requires a good deal of labor and some skill to make a careful study of a lens, the prospective buyer can make a few comparative tests with little expense and not much trouble. The lens can be examined for size of flare spots as described on page 45, and for evenness and general sharpness of definition by the simple process of photographing a large sheet of cross-ruled paper, if the lens is small. If it is intended for a large plate, detached pages of clear print are better, pinned to the wall in such positions as to bring one image in the center of the plate, one at each corner, and one or two in intermediate positions. Best of all are seven sets of concentric circles, which may be like those of Fig. 23, or preferably of rather finer lines. These should be drawn in India ink on smooth, unglazed paper and fastened to the wall as above. The so-called "test-charts" are satisfactory, but unnecessarily expensive and not always large enough unless cut up. To the circles a straight line should be added to test for distortion. This can be conveniently made from a waxed thread, white or black, according to the color of the background, so that a sharp contrast may be shown. It must be placed so that its image runs parallel to the long edge of the plate and close to it. The straightness of the line can be secured only by stretching it tightly between pins or nails, and (unless vertical) by sup-

porting it at several intermediate points upon additional pins, placed so that the line appears perfectly straight when sighted from either end. Any sag of course destroys the value of the test.

This simple test object, when carefully prepared and adjusted, will afford a severe trial of the power of definition of any lens. But it must be noticed that its indications are altogether misleading unless unusual care is taken in photographing it, particularly with lenses of fine quality, whose sensitiveness to imperfect focusing increases with the excellence of their corrections, particularly for spherical aberration. It is essential to have the axis of the lens perpendicular to the chart at its center, and the plate and chart must be accurately parallel. The sensitive film of the plate must lie exactly in the plane of the ground glass, which condition may be tested as described on page 91. The focusing must be done with a magnifier, and should be for maximum sharpness at the center of the plate. If the lens is a fine one, and used upon a large plate, it is also necessary to select a perfectly flat plate for the test photograph. All large plates are more or less concave on the film side, and the author has not infrequently searched through several boxes before finding a plate sufficiently flat for a fair test. The exposure must, of course, be made with the largest stop for which the lens is listed. For a definition test, the chart need not be uniformly illuminated; and, indeed, it is quite difficult to obtain uniform illumination of a large surface unless the exposure is made out of doors.

The resulting negative, which is more conveniently examined than the image on the ground glass, is a good guide to the performance of the lens. Astigmatism is quickly detected, the image appearing as in Fig. 23. If the corner images are

much blurred, and cannot be made sharper by refocusing, excessive spherical aberration is present. This can be separately tested by taking two additional photographs, one with the central portion of the lens (*i.e.*, with a stop about $\frac{f}{22}$), and a second one, without refocusing, with the marginal portion of the lens, cutting out the central area with a disk of black paper attached to the front lens by dampening it slightly. If the corner images can be improved by refocusing, which is very frequently the case, the field of the lens is curved, and the necessary change of distance between the lens and the ground glass gives the curvature between the center and edge of the plate. Distortion, if present, will be shown by the curvature of the image of the thread.

If the lens is to be used for copying or line work, the test object should be placed four or five focal lengths away from the lens. This is needlessly severe for a lens not intended for such work; for a lens that will give sharp images of distant objects is not necessarily corrected to give equally good definition of objects close at hand.

Care of Lenses. — A good lens is an expensive thing, and requires careful and intelligent treatment. Frequent cleaning of the glasses is not to be recommended; a few visible specks of dust do much less harm than the damage to the polished surfaces caused by indiscriminate rubbing. Every lens is supplied with a leather cap for the front glass; a second one, or better, a metal screw cap, should be obtained for the rear glass, and both kept in place when the lens is out of the camera or otherwise exposed. Fingers should never touch the glass surface; if they accidentally do, the marks should be removed with a soft cotton rag moistened with

alcohol, which must not be allowed to touch any other part of the lens. It is not superfluous to say that the utmost care should be taken to put back, in their proper order and position, any glasses which it may have been necessary to unscrew for cleaning.

Optical glass when made is beautifully transparent and colorless, but the requirements of the lens designer often compel the glass manufacturer to use materials of such kinds and in such proportions as to make the product liable to deterioration under certain conditions. Some kinds of glass are attacked by the moisture and acid gases of the air, and cannot be used except when cemented between others of a more resisting nature. Not a few discolor noticeably when exposed to light for a long time, and for this reason also it is well to keep lenses covered when not in use. Extremes of temperature are to be avoided when possible. No atmospheric temperatures will injure the glass or its metal mounting, but the balsam between cemented lenses is sometimes injuriously affected.

CHAPTER VI.

THE DIAPHRAGM.

BESIDES playing an important part in the theory of the lens system, the diaphragm or "stop" performs another useful function in practice. The images of objects at different distances from the lens of course do not lie in the same plane, and it is a matter of simplest observation to note that sharp focusing upon any object in a scene impairs the definition of other images. It is desirable in most cases to have a satisfactory distinctness over at least the larger part of the plate, and for a lens of fairly large aperture this is impossible unless the objects to be pictured lie at approximately equal distances from the lens. A diaphragm of small aperture achieves the desired result, but before going further it is necessary to establish a standard of definition.

In general, if an object-point is represented by an image-circle (called the *circle of confusion*) not more than 0.01 inch in diameter, the definition is satisfactory. For large pictures this is sharper definition than is necessary, while for lantern slides and negatives that are to be enlarged the circle of confusion should not exceed 0.004 inch in diameter. These limits are wholly arbitrary, and must in any case be determined solely by the purpose of the picture.

In Fig. 48 let the circles of confusion s , s' , have their diameters thus defined. Then it is plain that the plate may be placed anywhere between them and still show the necessary

sharpness of definition. In other words, all points will be sharply defined whose images fall in the spaces x and y . The length of this region is evidently dependent on the angle of the cone of rays emerging from the lens; the narrower the angle, the longer the space within which good definition is found.

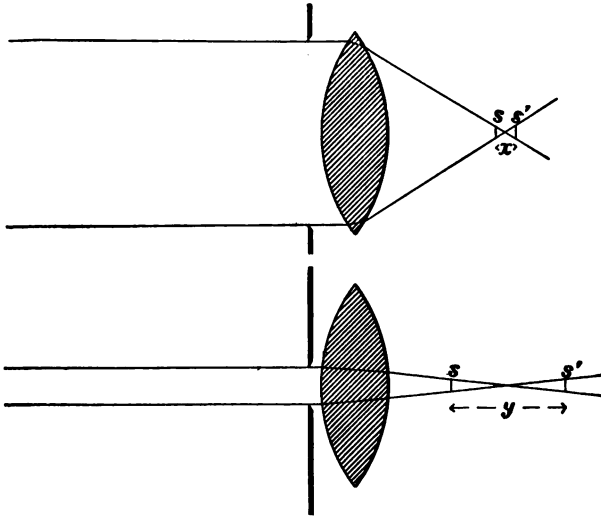

FIG. 48. Depth of Focus.

Thus it follows that points within a much greater range of distances will give sharper images with the narrow cone than with the wide one, and this is commonly expressed by saying that the "depth of focus" is greater in the first case than in the second. Since the effect is dependent only on the angle of the emergent beam, it is produced by the diaphragm, and is not at all a property of the lens itself. Lenses of short focal length have a greater depth of focus than long-focus lenses, because the images lie in planes that are closer together, so

that a given distance x (Fig. 48) represents a much greater range of object-distances with a short-focus lens than with one of long focus. For example, an infinitely distant object and one only 10 feet away from a lens of 3 inches focal length have their image-planes only 0.077 inch apart; so that a camera with such a lens might be adjusted once for all to have its plates come about midway between these planes, and would then need no focusing whatever for objects not nearer than 10 feet. This is the principle of all cameras thus fitted, and accordingly called "universal focus." Their simplicity does not arise from any superiority of lenses, — this quality is usually conspicuously absent, — but from the fact that the circles of confusion of short-focus lenses do not exceed the limit of fair definition on a plate so placed unless the object is very near.

Hyperfocal Distance. — It is not difficult to calculate, for any diameter and focal length of lens, how far distant a

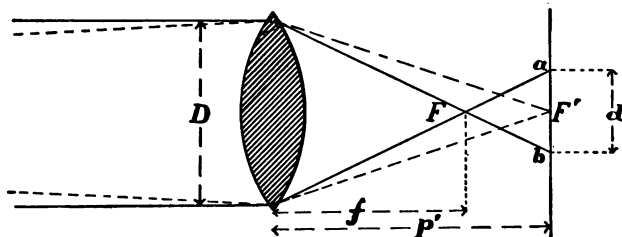

FIG. 49. Hyperfocal Distance.

sharply focused object must be in order that all beyond it may be defined with a distinctness according to the above limit. In Fig. 49, let F' be the image of the point whose distance p from the lens is to be such that the circle of confusion ab shall not exceed a diameter d , ab being the blurred image

of an infinitely distant point whose sharp image is at the principal focus F . Also, let

p' = distance of F' from the lens.

p = distance of point whose image is at F' .

D = effective diameter of the lens.

f = focal length of the lens.

= distance of F from the lens.

Then, from the similar triangles of the figure, having their common vertex at F ,

$$\frac{D}{d} = \frac{f}{p' - f}. \quad (18)$$

Combining this with equation (4),

$$\frac{1}{p} + \frac{1}{p'} = \frac{1}{f}, \quad (4)$$

in order to eliminate p' , and reducing, gives the result,

$$p = \frac{(D + d)f}{d}. \quad (19)$$

This distance p , beyond which all is in focus, is sometimes called the *hyperfocal distance*.

The following table has been computed from this formula, for various focal lengths and diameters of lenses, assuming d to be 0.01 inch and expressing the lens diameters as fractions of the focal length. The tabular numbers are the distances in feet beyond which all is in focus. From the table it appears that for lenses of fairly wide apertures a focal length of about $3\frac{1}{2}$ inches is the greatest that can be used satisfactorily in a fixed-focus camera.

TABLE III. HYPERFOCAL DISTANCES.
www.libtool.com.cn

f , Inches	f 4	f 5.6	f 6.3	f 8	f 11.3	f 12.5	f 16	f 22.6	f 25	f 32
3	19	14	12	9.7	6.9	6.3	4.9	3.6	3.3	2.6
4	34	24	21.5	17	12	11	8.7	6.3	5.6	4.5
5	53	36	34	26	18	17	13	9.3	8.8	6.9
6	75	54	43	38	27	24	18	14	12	10
7	103	74	65	52	37	33	26	19	17	13
8	134	96	85	67	48	43	34	25	22	17
10	209	149	134	105	75	68	53	38	34	27

Brightness of Image. — The diameter of the stop determines the area of the beam of light passing through the lens, and this affects the brightness of the image proportionately. This leads to several important conclusions.

If a luminous point is situated at a distance p from a lens whose diameter is D , the light falling upon the lens will be proportional to $\frac{D^2}{p^2}$. All this light will be concentrated at the image-point, no matter what the focal length of the lens, so that the following equation may be written:

$$\text{Brightness of image} = \frac{D^2}{p^2}. \quad (20)$$

That is, the brightness of a point-image depends on the area of the lens, and is independent of the focal length. This shows at once the great advantage of large-diameter lenses in stellar photography.

Now let the object have a linear dimension y — suppose it to be a square y on a side. Then the quantity of light falling upon the lens will be proportional to

$$\frac{y^2 D^2}{p^2},$$

and this will be spread out over an image of corresponding dimension y' , so that the brightness of the image will be proportional to

$$\frac{y^2 D^2}{y'^2 p'^2}. \quad (21)$$

But, from equation (5),

$$\frac{\text{linear size of object}}{\text{linear size of image}} = \frac{y}{y'} = \frac{p}{p'}. \quad (22)$$

Substituting this value of $\frac{y}{y'}$ in (21) gives

$$\text{brightness of extended image} = \frac{D^2}{p'^2} = \left(\frac{D}{p'}\right)^2. \quad (23)$$

Unless the object is very near the camera, p' differs but little from f , the focal length of the lens, so that (23) may be written

$$\text{brightness of extended image} = \left(\frac{D}{f}\right)^2, \text{ approximately.} \quad (24)$$

In other words, lenses having the same ratio of diameter to focal length give images of equal brightness; or, as usually expressed, lenses stopped down to the same relative extent require the same exposure for the plate. It is easily seen that this is not true for near objects, where p' is appreciably greater than f . In such cases, the image is less bright than the simple ratio indicates, and for near objects the exposure must be lengthened in the corresponding degree. Also, the analysis takes no account of possible difference between individual lenses owing to loss of light by reflection or absorption within the glass. The result, however, is sufficiently accurate to be directly available for all work except copying at close range, for which the value $\frac{D}{p'}$ should be compared with $\frac{D}{f}$, and the exposure made accordingly.

In general, therefore, it is a convenience to have the stops marked with the ratio of their diameters to the focal length of the lens, for by so doing the calculation of the exposure is greatly facilitated, either for a given lens or for different lenses. It is further very convenient, though not necessary, to have the various stops of such diameters as will give each one-half the area of the next larger one, thus requiring twice the exposure. One such system, used by many lens makers, is the following:

$$\frac{f}{4}, \frac{f}{5.65}, \frac{f}{8}, \frac{f}{11.3}, \frac{f}{16}, \frac{f}{22.6}, \frac{f}{32}, \frac{f}{45.2}, \frac{f}{64}. \quad (a)$$

This series requires the following exposures, in terms of the exposure for the largest stop as unity:

$$1, 2, 4, 8, 16, 32, 64, 128, 256. \quad (b)$$

This system is, of course, quite arbitrary, and any other might be used; as, for example:

$$\frac{f}{4.5}, \frac{f}{6.36}, \frac{f}{9}, \frac{f}{12.7}, \frac{f}{18}, \frac{f}{25.4}, \frac{f}{36}, \frac{f}{51}, \frac{f}{72}. \quad (c)$$

In engraving the numbers of the stops, only two figures of the denominator are commonly used, except for the largest, where three are sometimes given. As a rule, nothing is gained by using a stop smaller than about $\frac{f}{70}$, while there is a possibility of diffraction showing itself.

System (b) is also used for marking the stops, because it gives the relative exposures directly. It is called the "Uniform System" or U. S. numbering, and is the result of an

endeavor to facilitate exposure calculations as much as possible. It may be questioned, however, whether it offers any real advantage over the *f*-systems of numbering. The difficulty with systems like (a) and (c) is that makers are not in agreement on the subject, perhaps because, as a matter of convenience in using a given lens, the numbering should begin with its largest stop; and this, according to the type of lens, may be $\frac{f}{3.6}$, $\frac{f}{4}$, $\frac{f}{4.5}$, $\frac{f}{5}$, $\frac{f}{5.6}$, $\frac{f}{6.3}$, or larger, each

value being a perfectly legitimate starting-point for a separate series. In changing from one lens to another using a different numbering, some calculation is necessary to find the relative exposure necessary with corresponding stops; for example, to find what exposure must be given with a stop $\frac{f}{5.65}$,

knowing the exposure for another lens of aperture $\frac{f}{6.36}$.

This would be a very strong argument in favor of the Uniform System, were it not for the fact that the same difficulty appears there also, in the larger stops; one prominent maker, for instance, marking his lenses with the U. S. numbers 1.25, 1.44, 1.56, 1.90, 2.50, 2.90, 4, 8, and so on, with whole numbers beyond this point as in (b). Uniformity in numbering and simplicity of ratio are greatly to be desired, but have not yet been reached, at least in the larger stops.

The simplest way of getting the desired stop into the lens is to cut a slot in the lens mount, for the insertion of a diaphragm of blackened metal having the proper-sized hole cut in it; but this method is not to be recommended, except for indoor use, for it provides an opening for the entrance of dust and moisture, and the separate stops are easily lost.

A much better way for general work is shown in Fig. 50. The openings are cut in a circular disk centered upon the lens mounting as shown. By rotating the disk any stop may be brought into position, the exact centering being obtained by a little

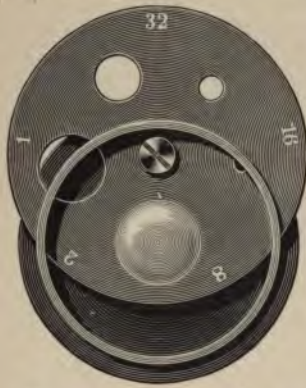

FIG. 50. Rotating Diaphragm.
Carl Zeiss.

pawl which drops into a slot in the disk when the center of the stop lies exactly on the axis of the lens. Five stops of different sizes are usually provided.

This arrangement has the merits of simplicity and small cost, and requires a minimum of space between the lenses. It is to be preferred when it is a matter of importance to have the stop of a definite size, as in stereoscopic photography, where

the stops of both lenses must, of course, be exactly alike. The arrangement illustrated is that adopted by the Zeiss firm for their smaller wide-angle lenses. The openings provided are those most frequently used.

Iris Diaphragm.—The other Zeiss lenses, and the great majority of fine lenses by other makers, are fitted with the iris form of diaphragm. This consists of a number of thin, overlapping leaves, preferably of metal, which are attached to a revolving ring so that they close up on each other or open out as the ring is turned forward or backward. The ring is sometimes turned by moving a pin in a slot, as shown in Fig. 39, but the more common construction, as shown in Figs. 12 and 37, has a rotating collar on the outside of the lens barrel, with its edge milled to give an easy grasp for

the fingers, and having reference marks to indicate the size of the diaphragm opening in various positions of the ring. This construction has also the advantage of keeping the interior of the lens closed against dust.

The iris diaphragm is compact and not liable to derangement. There is always more or less backlash in the mechanism, however, so that when the collar is turned to close the iris leaves together, the size of the opening left is not always the same as when the leaves are opened out to the same reference mark on the lens barrel. This difference is not usually of much importance, but it must be remembered in connection with exact work. It is not superfluous to point out that diaphragms are not always correctly marked; and a method, therefore, of measuring the diameter of the stop may not be without interest.

The effective diameter of a stop, by which is meant the diameter of the largest parallel beam that can pass through the lens with the given diaphragm, is always greater than the actual diameter of the hole in the diaphragm, except for single lenses, so that direct measurements on combination lenses are valueless. The excess varies with the type of lens, and differs considerably in different types. A simple method for measuring the effective diameter, based upon the definition just given, is as follows:

Focus upon a very distant object, in order to get the ground glass at the principal focus of the lens. Cover the ground glass with a sheet of opaque paper, in the center of which a small hole is pierced. Then if a candle is placed behind the hole the light passing through the hole and thence through the lens will be spread out into a parallel beam which will show on the front glass of the lens as a spot whose diameter

is the quantity sought. The measurement is rather easier if sunlight is used instead of a candle, because the spot of light is brighter. The various stops can then be inserted and their

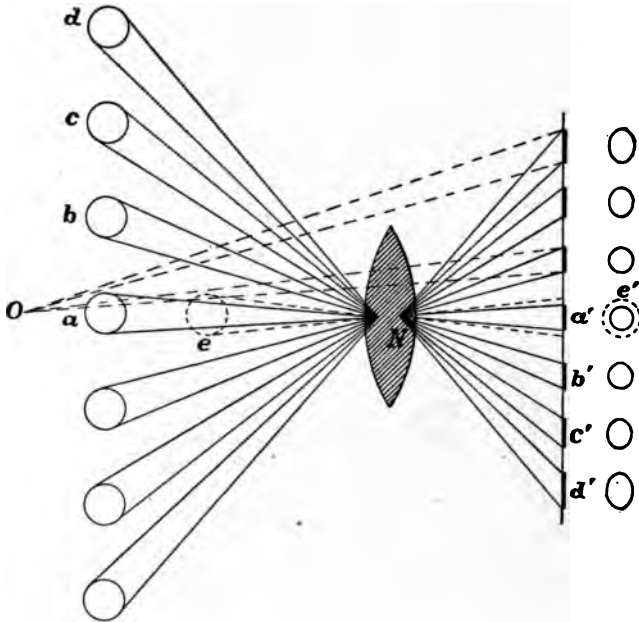

FIG. 51. Perspective of Lenses.

effective diameters measured, most conveniently and quite accurately enough by marking the edges of the circle on a strip of paper.

Perspective of Lenses. — The perspective of a lens is illustrated in Fig. 51. The outlines *a*, *b*, *c*, *d* represent a row of spheres, which of course appear as circles from any view-point. The images of these circles fall upon the plate as *a'*, *b'*, *c'*, *d'*, and are distorted into the elliptical forms there shown. Now

if these images are viewed with the eye at N , the nodal point of emergence of the lens, the visual angles they subtend will be the same as those of the objects themselves as seen from the same point (neglecting the trifling separation of the nodal points), and the eye will perceive no distortion. This point, with reference to the picture, is called the *station point* in perspective drawing. The eye, however, is not usually placed here, for the distance of distinct vision is about 10 inches for the normal eye, while the distance Na' , approximately equal to the focal length of the lens, is much less for the vast majority of lenses in use. Thus, for distinct vision, it is necessary to view the picture, not from N , but from some more distant point, as O .

It is easy to see that this new point of view alters the proportion between the visual angles subtended by a' , b' , etc., crowding the center of the picture and extending the sides; and the result evidently grows worse as the angle of view is increased. It is partly for this reason that the landscape painter seldom includes more than 25° or 30° in his pictures. Of course, for purposes of record, it is very often necessary to include angles much greater than these in a photograph, as in photographing interiors, buildings, or towers, or any large object at close range; but the results are invariably unsatisfactory pictorially unless the lens is of long focus, and this implies a very large plate. Even this, of itself, is not always satisfactory, for in viewing a large picture the spectator will unconsciously take a position at a distance such that the whole view can be seen without moving the eye, and this again demands a small angle for good pictorial effect.

The converse of the above proposition is also true: that a picture viewed from a distance less than the focal length of

the lens has its perspective distorted in the opposite way. In the actual case, however, lenses of more than 10 or 12 inches focal length are generally used for large-sized pictures, which are viewed from a distance in order to enable the eye to take in the whole without effort; and in the extreme case of telephotographic lenses of 5 or 10 feet focal length the angle of view is so small — from 3° to 10° — that the fault is not noticeable.

There is a further difficulty, entirely distinct from the preceding, also shown in Fig. 51. The circle e is of the same size as the circle a , but as it lies nearer the lens its image e' will be larger than a' , a result which on the finished picture obviously cannot be modified from any view-point. In fact, if the picture itself offers no further suggestion, e may be judged larger than a . As an illustration, it may be mentioned that it is a very easy matter, in the way just suggested, to photograph a 6-inch fish and its captor so that the result is quite imposing. With a short-focus lens, the two images a' and e' may be equally well defined, but with a long-focus lens the image e' will be poorly defined when the others are sharp, and the most natural thing to do, apart from using a small stop, is to remove the camera to a more distant position from which definition is better for e and a at the same time. But this helps to reduce the difference in the size of the images and thus to equalize the apparent size of the objects, of course improving the result pictorially.

The conclusion may therefore be drawn that long-focus lenses give better perspective than short-focus ones, partly because their pictures are more likely to be viewed at the proper distance, and partly because they cannot be forced to do what short-focus lenses will do readily, thanks to greater

depth of focus. The short-focus lens is thus in part the victim of its own greater adaptability. The following table gives some suitable values for focal length of lenses for various purposes and sizes of plate. It will be observed that nearly all lenses sold for general work have wider angles of view than those given in the table, as a result of the effort to make them "universal," that is, available for purposes where a distinctively wide-angle lens should be used.

TABLE IV. SUITABLE FOCAL LENGTHS FOR DIFFERENT PURPOSES.

SIZE OF PLATE.	DIAGONAL OF PLATE.	FOCAL LENGTH, INCHES.		
		Portraits.	Groups.	Landscapes.
$3\frac{1}{4} \times 4\frac{1}{4}$	5.35 inches	$9\frac{1}{2}$	$7\frac{1}{2}$	$5\frac{1}{2}$
4×5	6.40 inches	12	9	$6\frac{1}{2}$
5×7	8.60 inches	17	$13\frac{1}{2}$	$9\frac{1}{2}$
$6\frac{1}{2} \times 8\frac{1}{2}$	10.7 inches	20	15	11
8×10	12.8 inches	24	18	14
11×14	17.8 inches	34	27	19

Angle of View. — The matter of angle of view is naturally connected with the foregoing. This is sometimes taken to mean the angle of the cone of illumination of the lens, but a more workable definition is obtained by taking the angle of view embraced upon the plate for which the lens is listed; that is, the tangent of half the angle of view is equal to half the longer edge of the plate divided by the focal length of the lens. A lens having an angle below 45° may be considered narrow-angle, one having an angle between 50° and 70° may be called normal, and one with an angle over 75° distinctively wide-angle.

CHAPTER VII.

THE CAMERA AND ITS ACCESSORIES.

IN principle, the camera is only a light-proof extensible box with the lens and plate on opposite sides; in practice it is an elaborate piece of apparatus. The extension feature is obtained by making the sides of leather or light-proof cloth, folded into a bellows. The lens is generally mounted in a removable panel. This panel can be slid up and down in the camera front, or sometimes the whole front is made to slide, carrying the bellows up and down with it; and this adjustment, known as the *rising front*, is often needed to get some particular object into the view or out of it. The range of motion is limited by the size of the image-circle of the lens.

The ground glass, opposite the lens, must be held in position in such a way as to be readily displaced when the plate-holder is inserted. If it is mounted in a spring-supported frame, and the plate-holder inserted from the side, the camera is apt to turn upon the tripod when the holder is slid into place, unless the springs are very flexible; if the glass is fitted on hinges to swing out of the way, it is easily broken. Both methods leave room for improvement.

Tests. — Before going into service, and occasionally thereafter, every camera should be examined for possible leaks. The simplest way of making the examination is for the observer to remove the ground glass, place the head so that the interior of the camera can be easily inspected, and then hold

the camera up in sunlight with the lens closed, while an assistant wraps an opaque cloth over the observer's head and shoulders. The smallest crack or pin-hole will be distinctly visible, and must be carefully closed up before using the camera. This simple test will often prevent the fogging of plates whose cause would otherwise be unsuspected.

A second test is necessary, but may be made once for all. The sensitive surface of the plate should, of course, occupy the exact position of the matt surface of the ground glass. Unless it does so, no amount of care in focusing will give a sharp image on the plate. The only satisfactory way of testing this adjustment is as follows:

Set up a row of cards or blocks, one behind the other, and five or more inches apart, each marked with a sharply outlined letter or figure. With the camera about five focal lengths from the nearest, focus the middle card sharply on the ground glass with a magnifier, using the largest stop, and take a photograph. If the negative shows some other card more distinct than the middle one, the ground glass needs shifting forward or backward in its frame. The test may be easily and quickly made with half a dozen bricks, as many ordinary playing-cards, and a rubber band to hold each card to a brick. This condition of faulty register is not at all infrequent and is the cause of much unmerited criticism of lenses.

Focusing Arrangements. — Focusing is generally done by moving either the front or the back of the camera, though for hand cameras some lenses are provided with telescoping mounts which accomplish the same purpose. Still another method of achieving the result is shown in Fig. 52. The front glass of the lens is made to unscrew more or less; and as this lens (the Cooke lens) is very responsive to variations

in the distance between the two forward glasses, a slight turning of the screw alters the focal length enough to bring the



FIG. 52. Focusing Cooke Lens.
Taylor, Taylor & Hobson,
Ltd.

image upon the ground glass without altering the length of the camera.

When the focusing is done by adjusting the distance between the lens and the ground glass, either the front or the back of the camera must slide upon the camera bed, usually with the help of a rack and pinion movement. Cameras of the front-focus type have the

advantage of a fixed position for the ground glass, and the operator does not have to follow it up with his head when focusing — a convenience in confined positions. They have the disadvantage that with lenses of very short focal length a part of the camera bed is likely to intrude upon the field of view unless the section is made removable. Hand cameras are of the fixed-focus or front-focus types, and the latter are usually provided with a focusing scale of object-distances and a pointer, enabling the user to dispense with the ground glass in focusing, while a tiny camera called a *finder* shows in miniature the view that is upon the plate. Some cameras are made with finders or mirror mechanisms showing the view in full size, exactly as it appears when the exposure is made. Though expensive, they are very useful in photographing racing contests and other scenes where it is a matter of importance to know exactly what is being registered.

The table on page 80 shows that for lenses of not more than

3 inches focal length an average hyperfocal distance may be chosen; and by setting the plate at the focus for that distance, the definition will be satisfactory for all objects except those very near the camera. For lenses of longer focus the focusing scale of lens positions is usually marked for various distances up to 100 feet, and directions are given to set at that mark for all greater distances. But for a lens of 8 inches focal length (or more, *a fortiori*) the difference between the 100-foot focus and the focus for a very distant object is quite perceptible, and must be allowed for if the best definition is wanted; and similar care must be used in focusing for other distances. With such a lens, therefore, it is necessary to estimate distances quite closely in order to dispense with the ground glass. This leads at once to the conclusion that for the hand camera there is in practice a limit to the useful size of picture, which may be set at about 5×7 inches, since this is the largest size which should be covered with a lens of 8 inches focal length or less; and this limit is entirely apart from any considerations of weight or expense, which at about this point begin to increase rapidly. In using a lens of longer focus than 8 inches, without the help of the ground glass, it is necessary for the user to possess considerable skill in estimating distance, if the results are to be at all satisfactory.

Swing Backs. — The rising front will take care of small elevations, but in many cases the whole object can be brought into view only by tipping the camera. If the whole camera is tilted, lines really vertical will slope together on the ground glass, converging like the outlines of a church spire if the lens is tilted upwards. To get perspective which is correct when the picture is viewed in the ordinary way, it is necessary to have the plane of the glass parallel to that of the object,

and this requires that the ground glass and camera back shall be mounted in some way permitting them to be tilted forward or backward through the necessary angle. This feature is called the *vertical swing*, and is essential to all cameras intended for general work. A similar adjustment, called the *side swing*, is sometimes provided to meet corresponding conditions demanding movement in a horizontal plane. It is occasionally convenient, but rarely necessary. When either the vertical or the side swing is used, the plate is no longer perpendicular to the axis of the lens, and small stops are necessary to secure fair definition.

Reversible Back. — The long axis of the picture is usually horizontal, but it is sometimes desirable to have it the other way. It is possible to arrange the fittings of the camera, if a small one, so that it can be mounted on its side, but this is unsatisfactory; the manipulation of the apparatus is much easier if the camera back itself can be turned. In some patterns the camera back simply revolves in a circular mounting; in others the back is made square and can be slipped out and replaced after turning it quarter-way round. The first-named is called a *revolving back*, the second, a *reversible back*; and both forms require a square bellows. The first is perhaps a little easier to manipulate, and does not necessitate opening the camera box; but it offers no other advantages over the reversible form, and adds a little to the weight.

Tripod. — It is unfortunate that the enormous number of hand cameras in use has created a sort of standard of convenience, to which everything must conform, if possible, regardless of the results to be obtained. The truth is that hand camera work is a difficult and rather limited branch of the art of photography, and its standards of convenience and

results are not properly applicable to other classes of work. Whatever may be said by the enthusiast whose apparatus just fits his overcoat pocket, the seeker for best results must add certain accessories to his outfit, and the first of these is a tripod. The tripod should be light, rigid, strong, conveniently portable, and inexpensive. No such combination has been achieved in the history of photography. The essential requirement is rigidity, and this is difficult to secure without considerable weight. Every joint diminishes the rigidity, but it is troublesome to transport a tripod whose legs do not close into at least half their full length. It is a common mistake to use a tripod too small for the camera, and in such cases outdoor photography is very difficult when there is any wind. In telephotography two tripods or their equivalent must be used.

Focusing Cloth. — For a focusing cloth nothing is more convenient than black velvet, and the cheaper kinds are quite satisfactory. It is light, flexible, and does not slip readily from one's head and shoulders. The sole disadvantage of this material is that it is not waterproof, for in outdoor use a waterproof cloth may save the camera and plates from an unexpected and costly wetting. Excellent rubber-coated cloth is obtainable, however, which is almost as convenient as the other material.

Level. — A small spirit level, screwed to the camera base, is not absolutely necessary, but is very convenient for architectural and interior photography. It is an inexpensive luxury, and saves much time in leveling the camera so that vertical lines may retain their parallelism on the ground glass.

Magnifier. — Good definition can be obtained by the eye alone without difficulty, but when the most exact focusing

is desired a magnifier is needed. For critically examining the image on the ground glass it is best to use a form of magnifier designed to be placed flat upon the glass. For such critical definition the ordinary ground glass is not nearly fine enough, and a glass of especially fine grain must be used. In photography with the microscope the ground glass is replaced by a sheet of plain glass, in which case the image cannot be seen at all without a magnifier.

Plate-Holders.—Of all the forms on the market, only those can be considered satisfactory which do not require the fingers to touch the surface of the plate in filling or emptying the holder. The inside of each holder should be painted a dull black to prevent reflection as much as possible, and after the painting the holder should be allowed to stand open in bright sunlight until every trace of the odor of the paint has disappeared. In spite of this precaution, it is wise not to allow plates to remain in the holders more than a day or two before use. Plates which have been thus kept for a long time are apt to show more or less fog on development, although the holders may have been kept in the dark. It is at the present time the fashion to ascribe all such effects to some form of radio-activity of the paint or materials of the holder; but it is by no means proved that they are not due to some action which is purely chemical.

Kits.—These are thin wooden frames, fitting in the plate-holder, with the central portion cut out to hold a smaller plate than the size fitting the holder. In experimenting, and for some pictures, small plates are just as good as full-sized ones, and the difference in cost is often considerable; so that it is economical to have a full supply of kits of suitable sizes.

CHAPTER VIII.

COLOR-SENSITIVENESS OF SILVER SALTS.

APART from the question of the possibility of obtaining a photograph in natural colors, the image on the ground glass brings up the more restricted inquiry whether it is possible to obtain a faithful translation into monochrome with the usual photographic processes; that is, will the various colors of the image produce effects on the plate in proportion to their visual intensities?

A simple experiment — photographing a few flowers or ribbons of different colors — shows at once that the color-sensitiveness of the photographic plate differs greatly from that of the eye. Ever since the days of the alchemists it has been known that silver chloride darkens on exposure to light, and as long ago as 1777 Scheele allowed the solar spectrum to fall upon a sheet of paper coated with silver chloride, and observed that the surface darkened most rapidly under the violet rays, thus obtaining a measure of the relative activity of the different parts of the spectrum. The line of investigation thus begun has been carried to great lengths, but no systematic relation between visual and photographic sensitiveness has yet been found.

It is a fairly elaborate piece of work to measure accurately the comparative effects of the different spectrum colors upon a photographic plate, but the experimenter may obtain a good deal of interesting and useful information merely by

photographing a colored spectrum card.¹ It may be objected that the card colors are not pure spectrum hues, and therefore that the effect on the plate is not that which would be obtained from the spectrum itself; and the objection is a valid one if spectrum colors in their perfect purity are alone to be considered. Photography, however, deals chiefly with pigment colors, either natural or artificial, and the evidence derived from photographing pigments is entirely admissible in drawing conclusions to be applied in most of the cases that occur in practice. Pigment colors, either in nature or in art, are rarely pure; they are often mixtures of several others widely separated in the spectrum, and the matter is further complicated by the surface reflection of white light. The sensitiveness of the plate toward the pure spectrum is thus not an absolutely accurate index of its behavior to pigment colors. Indeed, from the photographer's point of view, it is well that the colors of nature are not pure as a rule, for in that case the contrasts of light and shade upon the plate would be much more intense.

PRANG'S PRISMATIC SPECTRUM

WITH THE FRAUNHOFER LINES

The Space Values of the Colors in this spectrum are based upon measurements given by Prof. Oscar H. Rood of Columbia College, New York



FIG. 53. Photograph of Spectrum Card on Ordinary Plate.

Figure 53 is a photograph of a card colored to represent the solar spectrum. The greatest photographic effect is in the blue about midway between the *F*- and *G*-lines, while to the

¹The prismatic spectrum card, published by the Prang Educational Company, is excellent for this purpose.

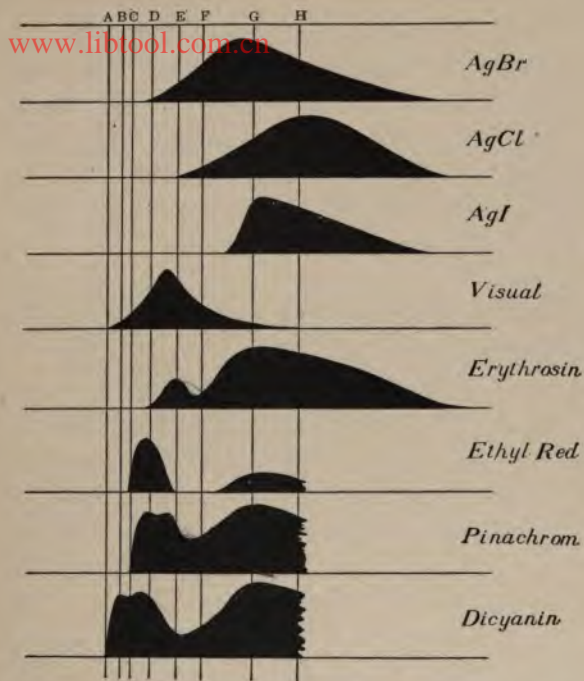

FIG. 54. Comparative Color-sensitiveness of Silver Haloids, with and without Dyes.

eye, the brightest part of the card is in the yellow near the *D*-line. It is plain that the rendering of the color luminosities is altogether false. However excellent the plate may be in recording differences of light and shade, it is clearly subject to serious limitations in the matter of color translation.

For various reasons the salts of silver hold the most prominent place in the list of substances sensitive to light, and all of them show the same general peculiarities. The comparative sensitiveness of the silver haloids to the different regions of the solar spectrum is shown in Fig. 54, where the

heights of the shaded areas are proportional to the sensitiveness to the corresponding region of the spectrum. For silver chloride, the maximum sensitiveness is in the violet, at or just beyond the visible limit; for silver bromide it is in the blue, and for silver iodide also in the blue, a little more toward the violet end. These substances are affected only slightly by red and orange and even yellow rays, and consequently objects reflecting light of these colors will appear dark or black in the finished picture. In this connection it may be observed that if a surface is to appear as black as possible in the finished photograph, it is usually better to cover it with a dark red cloth or paper rather than black, for the black surface reflects five per cent to fifteen per cent of white light, while the reflection from the red surface, though it contains a little white, is chiefly of a color (red) that does not affect the plate, and hence appears blacker in the print than the apparently "black" surface.

The violet and ultra-violet rays are the most active, not only for the salts of silver, but for ferric, mercuric, cupric, and uranic salts, for the chromates and the salts of gold and platinum, and in many of these a decided change in both color and composition is produced. This makes it not surprising that the violet end of the spectrum should long have been regarded as the seat of special chemical forces — an idea that is reflected in the division, in old treatises, of the spectrum into the three regions of heat, light, and chemical energy or "actinism." The distinction has long been abandoned, for it is not difficult to show that all parts of the spectrum can produce both heating and chemical effects. By prolonged exposure the curves of Fig. 54 extend themselves laterally both ways, but retain their original form, showing

that the difference of effect produced by the different parts of the spectrum is a difference of degree rather than a difference in kind of action. In the figure the ultra-violet rays appear very prominently, but in ordinary photography they are not of much consequence. Experiments have shown¹ that there is not a large proportion of ultra-violet light reflected from natural objects (the sun's ultra-violet rays are strongly absorbed by the atmosphere), and there is a further partial absorption of these rays in the glasses of the lens itself, the various kinds of glass employed not differing greatly in this respect.

The fourth curve of Fig. 54 shows the comparative visual intensity or luminosity of the different parts of the spectrum. This, therefore, would be the curve of sensitiveness of a substance giving correct monochrome representation of color. But though no such substance is known, and there is at present little indication of any way in which it might be prepared, an important advance in the desired direction was made by Dr. H. W. Vogel in 1873. He found that the addition of certain dyes to the light-sensitive silver salts changed the position of the maximum sensitiveness, and in general materially altered the shape of the curve. Such dyes are eosin, erythrosin, chlorophyll, and others; in recent years the list has grown enormously.

The fifth curve of Fig. 54 shows the sensitiveness of a silver bromide plate bathed in an ammoniacal solution of erythrosin. The sensitiveness is carried down into the yellow-green, without much change in the sensitiveness for blue and violet. Other dyes give results of the same general character. Eosin, like erythrosin, sensitizes the plate for yellow-green, cyanin

¹ Wood, *Philosophical Magazine*, February, 1903.

and ethyl-red for the orange-red, and chlorophyll for all parts of the spectrum except the extreme red. Among the dyes that have been recently used, pinachrome carries the sensitiveness into the red beyond the *C*-line. New dyes have been discovered which sensitize for the yellow and red, and the list is being extended almost daily. The three lower curves of Fig. 54 give the sensitiveness curves of collodion films bathed in ethyl-red and gelatine films bathed in pinachrome and dicyanin respectively.

The sensitizing dyes may be incorporated in the film when the plates are made, or an ordinary plate may be treated by the user by either of the following methods, with rather greater resulting sensitiveness.¹

ERYTHROSIN BATH.

Make a bath consisting of

Water, 100 parts.

Ammonia, 2 parts.

Erythrosin solution (1 erythrosin powder to 1000 water), 6 to 8 parts.

Soak a rapid plate in this solution for two or three minutes and dry on edge in total darkness.

PINACHROME BATH.

Make a bath consisting of

Water, 100 parts.

Ammonia, 1 part.

Pinachrome solution (1 part pinachrome to 1000 alcohol), 2 parts.

Soak the plate three or four minutes and dry as before.

Color Screens. — While the plates thus treated are sensitive to regions of the spectrum that would affect them but little otherwise, the sensitiveness to blue and violet is not

¹ *British Journal of Photography*, Jan. 27, 1905.

materially changed; and a photograph taken upon a plate thus treated will as a rule show but little improvement in color rendering except a slightly lessened gloom in the yellow and orange. Figure 55 is from the same card as Fig. 53,



FIG. 55. Photograph of Spectrum Card on Yellow-Sensitive Plate.

but taken upon a plate sensitized for yellow. By comparison with Fig. 53 it will be noticed that the sensitiveness for blue and violet is practically unchanged, so that the gain is only partial. In the usual case the sensitiveness for blue and violet almost completely overpowers the small additional sensitiveness gained at the other end of the spectrum. It is therefore necessary to cut down the blues in order to obtain correct rendering, and this is accomplished by a *color screen* or *light filter*.

The light filter is generally a sheet of transparent dyed gelatine placed somewhere in the path of the rays between the object and the plate. The gelatine is generally mounted between two thin, carefully-worked glass plates, and may be fastened either immediately behind or in front of the lens. Some filters are made of flat glass tanks containing a solution of the appropriate dye. They are less convenient and much more expensive than the simple glass plates, but have the advantage that the color of the solution can be adjusted to suit any requirement.

The result to be accomplished by the filter can be illus-

trated by the fifth curve of Fig. 54. If the portion of the curve to the right of the *F*-line is cut away, the remainder will have the same general form as the curve of visual intensity above, though on a smaller vertical scale. If the proportions of the curve are the same, of course the actual equality of effect could be obtained by merely lengthening the exposure. A similar result could be secured by trimming down the two lower curves to the desired form. This trimming down, *i.e.*, absorption of the undesired rays — is the function of the filter. No argument is necessary to show that for accurate results the filter must be carefully adjusted to the plate upon which it is to be used. The technical difficulties of accurate adjustment are very great, and for processes involving the reproduction of colors, as in color printing and natural color photography, the complete solution of the problem cannot be said to have been found thus far.

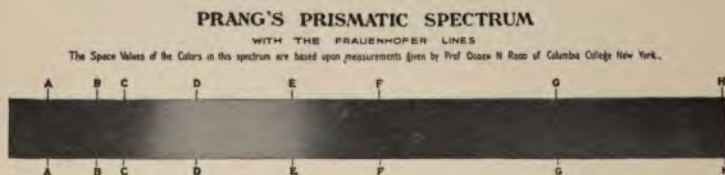

FIG. 56. Photograph of Spectrum Card, on Yellow-Sensitive Plate with Ray Filter.

Figure 56 is a third photograph of the spectrum card, this time with a plate sensitized for yellow with the excessive blue-sensitiveness reduced by an orange-colored filter permitting only a very little blue to pass. The photograph represents very fairly the luminosity of the particular card used, except for the red, to which the plate was not sensitive.

Plates thus sensitized for particular regions of the spectrum

are called by the general name *orthochromatic* or *isochromatic*. Strictly speaking, an isochromatic plate is one equally sensitive to all parts of the spectrum, but in ordinary usage the terms are synonymous. The orthochromatic plate of the supply houses is sensitized for yellow and orange, rarely for red. Red-sensitive plates are obtainable, but they are usually distinctly classed as "red-sensitive," and not by other names.

The advantages of orthochromatic plates are very great for all photography involving color. Flowers, skies, autumn and even summer landscapes, paintings, fabrics, and similar subjects may be mentioned as everyday examples. When first put upon the market, these plates had very inferior keeping qualities; but at the present time even the most sensitive brands are excellent in this respect, though not quite as good in keeping qualities as the undyed kinds.

An important practical difficulty in working remains to be mentioned. The filter does its work by removing the rays that interfere with correct color rendering, but as the rays removed are the ones that are most effective upon the plate it is necessary to make up the deficiency by increased exposure. An absolutely correct rendering would cut out so much light as to increase the exposure forty to sixty fold. This is usually prohibitive, so a compromise must be made. A light yellow screen will cut off enough blue to improve matters considerably, at the cost of a fourfold exposure. Clouds in the sky, different shades of green in the foliage, and other color differences show themselves. An orange screen will give excellent rendering, and will require about seven times the normal exposure; while specially prepared screens can be obtained, giving true rendering for all but the reds, and necessitating about fifteen times the normal exposure.

The dyes used in the filters of commerce are, of course, trade secrets; but the photographer who is fond of experimenting can get a good deal of information by trying solutions of aurantia and naphthol-yellow, first coating glass plates with a ten per cent solution of gelatine allowed to dry, and then soaking the plates in the dye solutions.

Action of the Sensitizing Dyes. — The nature of the effect produced by the dyes upon the silver salt has not yet been settled beyond dispute. It is possible that the dye may form a compound with the silver salt, for a dyed plate may be washed until every trace of color disappears without destroying its orthochromatic properties. This hypothesis, however, is apparently incorrect, for it has been shown that many so-called dye-solutions are not true solutions at all, but merely very finely divided suspensions, from which it is possible to separate the dye-particles by repeated filtering. It has long been known that the dye solution must not be stronger than one or two parts in a thousand, a fact which recent experiment has shown to be due to the formation of larger dye-aggregates in the more concentrated baths, whereas if they were true solutions the strength of the bath would be of little consequence. Alcohol in the sensitizing bath, which has also long been known to be beneficial, has been shown to make the dye-particles finer. This effect readily explains the increased sensitiveness caused by the use of alcohol, for if the dye-particles are made smaller and therefore more numerous, it is obvious that a greater number of silver molecules can be reached, while an increase in the strength of the dye-solution, which only increases the size of the dye-particles, might be expected to produce no such result. In the case of dyes which fade on exposure to light, it is possible that

the faded dye acts as a nucleus on which the silver is later deposited by the developer, and the image built up in that way. All dyes used for color sensitizing, when examined by the spectroscope, show an absorption in that region of the spectrum for which they increase the sensitiveness of the plate. This rule appears to have no exception, and indeed should not have, according to the principles of energy transformation. Its converse, however, is not necessarily true; that is, a dye whose spectrum shows an absorption band does not *ipso facto* sensitize a photographic plate for the corresponding region of the spectrum.

Light for the Dark Room. — After exposure in the camera comes the process of development, during which the plate requires occasional inspection; and, of course, it must not be affected by the light used for this purpose. Ordinary (undyed) plates are but slightly sensitive to yellow, and are almost entirely unaffected by orange and red; so that either of these colors, if pure, might be used for lighting the developing room. It is not easy, however, to get a yellow which will not allow a little green to pass, and it is therefore customary to use orange or red, in the form of paper, glass, or specially prepared cloth fabrics. Glass is best, but rather expensive; a sufficient and inexpensive protection, for all ordinary plates, can be made from a sheet of yellow fabric, backed by a sheet of ruby fabric, or by two sheets if the plates used are very sensitive.

It is much more difficult to provide a safe light for rapid orthochromatic plates, as they are quite sensitive to red light. It is necessary to use a deep red glass for the common brands and to expose the plate as little as possible to the light, keeping the tray covered until development is judged to be nearly

complete. Some orthochromatic plates are made insensitive to certain regions of the spectrum, and dark-room glasses are provided by the plate maker of colors exactly corresponding to the insensitive region. This is a most effective and elegant method of avoiding the difficulty. An illustration may be seen in the ethyl-red curve of Fig. 54. The plate is insensitive to the region about the (green) *F*-line, and such plates can therefore be developed in green light without harm.

Test for Dark-room Lamp. — Before proceeding to the development of plates, it is highly necessary to test the safety of the dark-room illumination. The room itself should be as large as practicable and provided with a good-sized table, running water, and a spacious sink. Unless the ventilation is extremely good, gas or kerosene developing lamps should be placed outside the room, and allowed to shine through a window covered with glass or fabric as described. The safety of the light should be tested by covering half of a rapid plate with black paper and exposing the other half for a minute directly in front of the lamp. If on developing the plate the two halves are not alike, the light must be further shielded. This is a rather severe test, for after the plate is once plunged beneath the surface of the developing bath it loses a large part of its sensitiveness, and the development of a properly exposed plate rarely takes more than five or six minutes; but it is wise to be on the safe side to provide for the exceptional case.

CHAPTER IX.

PHOTO-CHEMICAL ACTION.

THE fading of dyes in carpets, wall-paper, and fabrics affords an everyday example of the chemical action produced by light; and the chemist is familiar with many other physical and chemical changes due to the same cause. For photographic purposes the most important action is the partial reduction of certain compounds, chiefly by the rays of shorter wave-length. The principal substances of interest in this connection are certain salts of silver, iron, and chromium.

The efforts of early workers in this field were naturally directed to those substances which show the greatest change of color when exposed to light. Discoloration, however, is not a true measure of sensitiveness, for it will be shown later that the color is in a sense accidental. A combination of substances giving a visually indistinguishable reduction-product may be vastly more sensitive than one showing a marked change of color. But to make such a reduction-product visible, it is necessary to treat it with some substance that will bring out a difference of color or other properties, the more marked the better. Such substances are called *developers*; the process of development is considered in a following chapter.

To return to the subject of the reduction of compounds by light, it is only reasonable to expect that the reduction will be facilitated if some substance is present to absorb or com-

bine with some of the reduction-products; and this is found to be the case. For example, the silver haloids (the chloride, bromide, and iodide) are reduced to compounds having less of the halogen, and the reduction is greatly aided if some halogen-absorbing substance is present. Thus, gelatine is a strong absorbent of bromine, and silver bromide in gelatine forms a very sensitive combination. Silver iodide will not be reduced at all unless some iodine absorbent (*e.g.*, silver nitrate) is present. Silver chloride with silver nitrate is more sensitive than silver chloride alone, because silver nitrate absorbs chlorine. The converse of the proposition is also true. Substances tending to prevent the liberation of the halogen act in the corresponding way. For example, mercuric and stannic chlorides diminish the sensitiveness of silver chloride, because these substances tend to prevent the liberation of chlorine. It follows, therefore, that the sensitiveness of a given substance may depend in large measure on the substances associated with it.

Dry Plates. — Among all the substances sensitive to light, the most widely useful, for various reasons, is silver bromide, and dry plates at the present time depend chiefly upon it for their sensitiveness. The preparation of gelatino-bromide plates is in principle a simple matter, though their manufacture on a large scale is not easy. It is entirely possible for any one having a fair degree of manipulative skill to make his own plates, and if very great sensitiveness is not aimed at, they will be quite as good as any purchased from dealers. For details the reader must be referred to manuals;¹ but the principle is as follows:

¹ ABNEY, "Instruction in Photography." HARRIS, "Practical Slide Making."

Silver nitrate is dissolved in a gelatine solution ; and potassium bromide, with a little potassium iodide, is dissolved in water separately. The two solutions are mixed, and the following reactions take place:

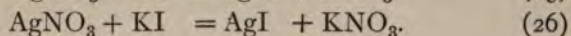
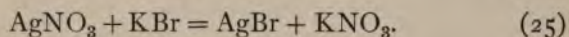

The precipitated silver salts are insoluble and remain in the gelatine in the form of minute grains. Heating for some minutes at the boiling point increases the sensitiveness of the emulsion, and during this process the particles collect themselves into larger aggregates, so that a very sensitive plate is always of coarser grain than a slow plate. The mass of emulsion is then allowed to cool and solidify to a jelly, after which it is broken up into fine shreds by forcing through coarse cloth, for the purpose of washing out all the soluble salts. After washing, it is allowed to drain, transferred to a suitable vessel, melted by gentle heat, and poured over carefully cleaned glass plates. The plates are allowed to dry for some hours, and are then ready for the camera. All the manipulations, beginning with the mixing of the silver and potassium salts, are conducted in red light.

In a word, then, the modern dry plate consists of a gelatine film containing emulsified silver bromide and iodide, mounted upon a transparent inert support. The most convenient support for manipulation is glass, but the weight and bulk of glass plates make them inconvenient for the tourist. Paper supports have been repeatedly used, but though cheap are not very satisfactory, partly on account of lack of transparency, but chiefly because of the difficulty of getting a material sufficiently structureless not to show a grain on the finished

picture. Celluloid was invented in 1869, and was successfully used as a support in 1889. In the "films" as now made the emulsion is spread over a sheet of transparent and colorless celluloid, which for hand cameras is sometimes made long enough to contain 250 exposures. They offer to the tourist the important advantages of convenience, unbreakability, light weight, and trifling bulk, at a somewhat greater cost than glass plates.

If permitted to do so, the gelatine will shrink in drying after development and fixing, and thin celluloid films consequently curl up in a most exasperating way. The difficulty is partly overcome in the so-called "non-curling" films by coating the back of the support with a layer of plain gelatine to counteract the shrinkage tendency of the film on the other side.

Quantity of Reduction-product. — The excessively small quantity of the product which is formed by the action of light on the silver salts in gelatine has thus far enabled it to escape detection, and even raises the question whether there is really any reduction-product formed at all. Supposing that an actual chemical reduction takes place, some idea of the amount formed can be gained from the following calculation.

A fairly rapid plate, exposed for ten seconds to the radiation of a lighted candle at the distance of a yard, will have received a very full exposure, and the amount of reduction-product thus formed may be taken as the maximum obtainable under normal conditions. Suppose, for definiteness, that the light is that of a standard candle, burning 120 grains per hour, or 0.00216 gram per second. The heat of combustion of the spermaceti is about 10,000 calories per gram, so that the energy set free is 21.6 calories per second, or 216

calories for the whole exposure. This energy is distributed over 16,300 square inches, the surface of a sphere two yards in diameter, and the energy received by each square inch is 0.0133 calorie, assuming it to be distributed uniformly. But of the whole amount only about one per cent is photographically active, the balance being lost in heat or inactive radiations, so that the total amount effective is only about 0.000133 calorie.

To find how much silver this can reduce, it is necessary to make use of the experimental fact that the heat of formation of silver bromide is 22,700; that is, 108 grams of silver, uniting with the necessary amount of bromine to form silver bromide, will give out a quantity of heat equal to 22,700 calories; and that, in consequence, to reduce 108 grams of silver from a mass of silver bromide, the same quantity of energy is required. A simple proportion shows from this that the energy available will liberate only 0.00000063 gram, or 0.00000042 grain, of metallic silver on each square inch of the photographic plate. It is unnecessary to enlarge upon the difficulty of analysis with such an infinitesimal amount of material, embedded, as it is, in a much larger mass of unaltered silver bromide.

It may, however, be properly objected that the reduction does not necessarily take place as indicated in the above calculation, but that a sub-bromide may be formed, requiring less energy for its formation in the first place, and that in the presence of the gelatine, which is an active bromine absorbent, a smaller quantity of energy may suffice to effect the reduction. The objections are valid beyond question, but the quantity resulting from the preceding calculation may be multiplied by any reasonable factor, in allowing for these

effects, and still lie below the limit discoverable by existing methods of analysis.

The Nature of the Latent Image. — Ever since the discovery that an invisible light-effect could be developed into a strong image by the application of suitable reducing agents, the constitution of the invisible or so-called "latent" image has been the subject of study and controversy. The known fact is simply that the latent image on the photographic plate consists of some modification of the sensitive film, by which the silver haloid is more easily reduced to metallic silver, as in the dry-plate process, or by which metallic silver is precipitated from a solution upon the particles affected, as in the wet-plate process. It has also long been known that prolonged exposure to light results in the formation of reduction-products containing less than the original proportion of the halogen. Further, a developable impression can be produced by agencies other than light, among them being X-rays, mechanical pressure, electric discharges (visible or otherwise), and emanations of various kinds from chemical compounds and radio-active substances. A few of these are described in a following chapter.

To explain the nature of the latent image, four hypotheses have been advanced. They may be described as follows:

- (a) The silver grain hypothesis.
- (b) The sub-haloid hypothesis.
- (c) The molecular strain hypothesis.
- (d) The ionization hypothesis.

The Silver Grain Hypothesis. — This, which has been put forward in one form or another by various writers, is in brief that the action of light is to form a minute quantity of metallic

silver, in discrete particles which act as centers of deposition when the developer is applied to the plate. As these particles would have to be almost of molecular dimensions, and by the calculation of page 113 of very small total quantity, it is clear that no direct physical evidence of their presence can be expected, but that the behavior of the plate toward various chemical reagents must be relied upon for proof or disproof of their existence. It is not necessary here to go deeply into the discussion of the nature of this evidence; it seems fairly conclusive that no metallic silver is produced by such exposures as will give ordinary negatives. The silver grain hypothesis is not widely held at the present time.

The Sub-haloid Hypothesis.—This explanation of the nature of the latent image is the one that has received the most general acceptance. It assumes that the latent image consists of partially reduced silver haloid; that is, in the case of silver bromide, that a sub-bromide is produced which contains less than the normal proportion of bromine. Various formulæ are assigned to this reduction-product, nearly all of which may be represented by the expression

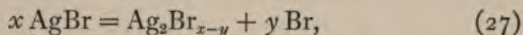

in which x and y have variously assigned values. The simplest form of this expression is

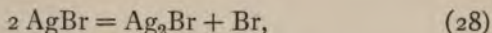

which has been much used, but which has little to recommend it except convenience in writing equations.

When closely examined, however, equation (27) is much less convincing than it appears. In the first place, no direct evidence has ever been found that such a reduction-product

is actually formed. If it exists, its exceedingly small amount has thus far successfully defied detection. Its existence is purely an inference from an analogy that is not only defective from the chemical standpoint, but also from the fact that there is no certainty that the latent image is of the same composition as the reduction-products obtained by very long exposures.

Recent work ¹ appears to show that if reduction-products are really formed as indicated by equation (27), the process consists in the formation of a series of such compounds, beginning with one containing but little less than the normal proportion of bromine, and continuing with others containing less and less bromine as the exposure is lengthened, up to the point of extreme length of exposure, where visible darkening of the film appears and quite different compounds are formed of unknown composition.

The difficulty with the sub-haloid theory, then, in addition to the fact that silver and bromine are both monovalent and therefore formulæ like Ag_2Br are objectionable, lies simply in the absence of proof that any chemical change at all has occurred, at least in normal exposures. Experiments have shown that photographic plates retain about one-tenth of their sensitiveness at the temperature of liquid hydrogen (-253° Centigrade), whereas even the most active elements, like fluorine, lose their chemical activities at much higher temperatures. This would appear to be strong evidence that the change on the plate is not due to chemical action. It is further not necessary that there should be a nucleus of silver or silver haloid as a center of deposition, in order to explain the process of development, for it is possible to pass an electric

¹ EDER, *Zeitschrift für Wissenschaftliche Photographie*, Bd. III, 1905.

spark over a clean glass plate and then to develop an "image" of the path of the discharge, using the ordinary wet-plate developer (ferrous sulphate and acetic acid) to which a few drops of silver nitrate have been added. Most of the phenomena of the latent image can also be produced on a plate of polished silver by the direct action of sunlight, which suggests a possibility of gas action, a hypothesis supported by the fact that atmospheric oxygen appears to be necessary to the formation of the latent image in general.

Molecular Strain Hypothesis. — In addition to the many chemical changes caused by light, it is also a familiar fact that well-marked changes are produced in the physical and electrical properties of many substances, without detectable change of chemical composition. In view of this fact, at least for the cases where the final result of light-action is a chemical change, it is not unreasonable to suppose that before this point is reached the action of light might be such as to change the physical properties of the molecule, either by rearrangement of its constituent atoms or by the establishment of mechanical strains under which the molecule can be broken apart more readily by the developer. Professor J. G. Bose has contributed a large amount of most suggestive experimental work along this line,¹ which may be taken as the expression of the molecular strain theory. It affords abundant opportunity for extensive investigation, both as to the nature of the strain within the molecule, and the harmonizing of the theory with the known facts of chemical activity.

The Ionization Hypothesis. — The fact that light-waves, particularly those most active photographically, have the power of discharging a negatively electrified body, has been

¹ BOSE, *Journal of the Royal Photographic Society*, 1902.

shown to be due to the electric force of the light-wave, which facilitates the escape of negative electrons from the surface of the charged body. Under suitable conditions an uncharged body will acquire a positive charge, due to the escape of negative electrons and the consequent development of the equivalent quantity of positive electrification; and the molecule itself and even the atom can be broken into two portions, one negatively and the other positively electrified. The negative electron attaches itself to some other molecule; and the point of importance for the present argument is that the escape of an electron from a molecule may result in the appearance of an entirely new set of physical and chemical properties, while the attachment of the liberated electron to some other molecule or atom may confer upon it also a new set of properties. This is a familiar principle of electrolytic conduction.

Quantitatively, the above photo-electric effect is in accord with the known sensitiveness of the silver haloids, and there is other experimental evidence in the same direction. It would therefore seem possible that the light-action may begin with the discharge of an electron from the light-sensitive molecule, and that the action of the developer is directed at first to the molecule thus affected. This theory, propounded by Professor John Joly, is of much interest, but also awaits further development.

CHAPTER X.

DEVELOPMENT AND DEVELOPERS.

IN order to bring about a visible difference between the light-affected substance and the unaltered regions of the plate, it is plain that the developer must act differently upon them. A developer may be defined as a substance which acts unequally upon the altered and unaltered parts of the plate, and it is of course highly desirable to have this inequality of action very great, extending, if possible, to a difference in kind of action rather than in mere degree.

There are two general methods of development, which may be called *physical* and *chemical*. In the former, the developing process is a purely physical operation, as in the daguerreotype and carbon processes; but the term is now also applied to a chemical reaction by which the silver image is built up out of material supplied from a solution, as in the wet-plate process. The chemical methods of development may be separated into two classes. In the first class the developer acts upon the altered substance, with little or no chemical effect upon the unaltered salt. The blue print and platinum print are examples of this kind of action; and in such cases the strength of the resulting image is directly proportional to the amount of reduction-product formed by the light. In the second class the action of the developer upon the altered substance is followed by a secondary reaction between the new product and the unaltered salt, which

in its turn is reduced by the developer. In this way a strong image may be built up from a very minute quantity of the original altered salt. The dry-plate process is the best example of this, and is considered more fully below.

Methods of Development. — It is therefore possible to classify the various methods of development, according to the manner of their action, as follows:¹

(1) The altered substance may have an affinity for metallic or other particles not possessed by the unaltered salt.

The best example of this is the daguerreotype process, first published in 1839. Daguerreotypes are made by first polishing a silver or silver-plated copper plate, and exposing it to the vapors of bromine and iodine, by which the surface of the silver is converted into a film of silver bromide and iodide. After exposure in the camera the image is developed by holding the plate over the vapors of warm mercury. Metallic particles condense from the vapor upon the portions of the film that have been affected by the light, the condensation increasing with the exposure, and the image is thus brought out as a white amalgam of silver and mercury. The plate is then fixed — to remove the unaltered silver salts — and the image given a more pleasing color by immersion in a toning bath of gold chloride, by which metallic gold is deposited upon the image. For the present discussion the point of importance is the attraction which the light-affected salts exert upon the mercury vapor particles, a power not shared by the unaltered salts.

(2) The altered substance may be capable of reducing a metallic salt or solution which the original salt cannot decompose.

¹ ABNEY, "Treatise on Photography."

An example of this is seen in the wet-plate process, now used chiefly for the production of lantern slides. A glass plate, coated with a film of collodion containing a soluble bromide and iodide, is sensitized by bathing it in a solution of silver nitrate, and exposed in the camera while wet. With the aid of an acid developer (a solution of ferrous sulphate acidified with acetic acid) the substance formed by the action of the light is able to reduce the silver nitrate to metallic silver, which forms the image. In this case, then, the image is built up from material supplied by a solution. This particular process is also sometimes called physical development, to distinguish it from the chemical development of the dry plate, as described in the next division.

A second example is furnished by the platinum process. The paper on which the image is to be produced is coated with ferric oxalate and a platinum salt, the light reducing the former to ferrous oxalate without affecting the latter. The developer is a solution of potassium oxalate, which with the ferrous salt reduces the platinum salt to the metallic state, building up the image in metallic platinum.

(3) The altered product, perhaps already partially reduced by light, may be still further reduced to the metallic state by solutions which are unable to affect the original salt, and this reduced metal may serve as a nucleus upon which a more intense image can be built by secondary reaction with the unaltered salts in the film. This is the principle of the development of dry plates, which is discussed more fully below.

(4) When treated with metallic or other solutions, the altered substance may show a strong contrast of color with its background.

The blue print is a familiar illustration of this. In the blue print as it comes from the printing-frame the insoluble reduction-product formed by the light-action is not greatly different in color from the unaltered salts; but the application of water turns it to a brilliant blue, while the unaltered salts wash readily away.

(5) The altered substance may be insoluble or only slightly soluble, while the original substance may be readily dissolved.

This is shown in the so-called carbon or gum processes. In these, paper is coated with gelatine or gum arabic containing some inert pigment, and the coating is then sensitized by immersion in a solution of potassium or ammonium bichromate. Exposure to light renders the bichromated gelatine insoluble, and the unaffected portions can be washed away in warm water, leaving the image composed of the insoluble portions.

(6) The altered substance may be incapable of absorbing moisture. This is the foundation of several mechanical printing processes, depending on the behavior of wet and dry surfaces toward greasy ink, upon the production of relief by swelling of the absorbing portions of the image, and so on.

With the above variety of methods of treatment, it is not remarkable that the color of the image should differ widely in different processes. It may in a sense be considered even accidental. For example, let a sheet of paper be brushed over with a 15 per cent solution of uranium nitrate, and, after drying in the dark, be exposed to sunlight under a sheet of opaque paper with a few holes cut in it. The reduction-product under the openings is barely visible, but will give a brown image when treated with a solution of potassium ferri-

cyanide, because the color of uranium ferricyanide happens to be brown. Different developers will give different colors. The uranous reduction-product will reduce the salts of silver and gold, and if silver nitrate and gold chloride are used as developers, the image will be brought out in finely divided gray silver or bluish gold.

It is possible to go still further, and to produce at will either a positive or a negative, in certain cases. A sheet of paper prepared as for blue-line prints (Chapter XV) and exposed under a perforated card will show blue spots on a white ground, or white spots on a blue ground, according as it is brushed over with solutions of potassium ferrocyanide or ferricyanide.¹

Quite apart from its function of producing a visible image, it is therefore possible to regard the developer in general as a detector of the existence of a very small amount of chemical or physical change of certain kinds; and if these changes can be produced in any way other than by the action of light, the resulting "image" can be developed just as readily. Some examples of this are given in Chapter XI.

Development of the Dry Plate. — In discussing the theory of dry-plate development, it is customary to use equation (28) or some modification of it, purely for the sake of convenience. But whatever the actual composition of the altered substance may be, the action of the developer upon it reduces it to metallic silver; and this plainly requires disposal of the bromine set free by the reaction. Hydrogen has a strong affinity for bromine, and is present in abundant supply in the water of the developing bath; but this in turn requires the presence of something with which the oxygen of

¹ MELDOLA, "The Chemistry of Photography."

the water may combine. The active agent of the developer must provide this, and therefore must be a ready absorbent of oxygen — that is, a reducing agent.

It is important that the reducing power of the developer should not be great enough to enable it to attack the unaltered silver salts as well as the light-image, for, in that case, the reduction will take place over the whole plate, causing what is termed *jog*. Thus the proposition is not reversible; every developer must be a reducing agent, but every reducing agent is not necessarily a developer.

The hydrobromic acid produced by the action of the developer would retard the reduction if allowed to remain free, but combines with the alkali of the developing bath, setting free in turn some milder acid, as CO_2 , which is without effect on the plate. The function of the alkali is thus to accelerate the reduction, as may be shown by the following experiment:

A solution of pyrogallol in water is colorless when freshly made, but will slowly absorb oxygen from the air and turn yellow in consequence. The addition of a little caustic potash greatly accelerates the action, and the color rapidly changes from yellow to brown by the formation of oxidation products, the discoloration beginning at the surface and spreading through the liquid. But if a small quantity of sodium sulphite is added before the alkali, the liquid will remain clear, though tinted. The sulphite itself oxidizes and to that extent protects the developing agent and keeps the bath clear.¹

This action is typical, and leads to the conclusion that a developer for dry plates should consist of—

1. Reducer.
2. Accelerator.
3. Preservative.

¹ COLSON, "Le Plaque Photographique."

If the preservative is omitted, the developer rapidly oxidizes and can as a rule be used only once. The accelerator is some alkali, and may be either ammonia or more generally carbonate of sodium or potassium. The reducer, the active agent in the process, is usually of organic origin and complex molecular structure. Some of these substances are sufficiently alkaline in themselves to be used without an accelerator. The list of reducers is very long, and is constantly being extended.

In the case of the dry plate the action of the developer does not stop with the reduction of the primary light-image to metallic silver. The complete reactions in any case will depend both upon the nature of the latent image and the particular reducing agent employed; but on the sub-haloid theory the following equations represent at least possibilities, and are often quoted:

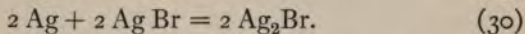
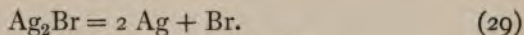

Though these equations have little to justify them quantitatively, it seems certain that some action of the sort takes place, as was beautifully shown by Abney.¹ A plate was coated as usual, then exposed, and then coated with a second film of collodion, after which it was developed without further exposure. When dry, the unexposed collodion film was split from the exposed film, and an image was found upon both. From this it appears clear that the action of the developer is first to produce a substance (probably metallic silver) from the primary light-image, and that this substance reacts with the unaltered silver bromide to form a new compound,

¹ *Philosophical Magazine*, January, 1877.

which is attacked and reduced in turn, the final stage of every reduction being metallic silver. The image is thus gradually

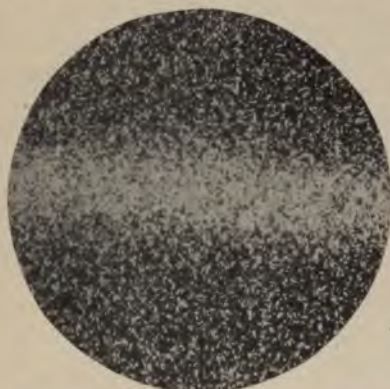

FIG. 57. Photomicrograph $\times 200$. Silver Deposit on a Rapid Plate.

formed from the silver in the film, beginning at the surface and penetrating deeper and deeper into the gelatine; and by continuing development the image will gain steadily in density until all the silver present has been reduced, when of course the process ends. Except, however, for films containing only a very small

quantity of silver, it is not necessary to carry development to this stage. The process of fixing, described later, removes the partially reduced silver compounds and whatever silver bromide may have survived this treatment, leaving the image as a low relief of black silver particles. The relief may be plainly seen after drying, by examining the light reflected at a suitable angle from a negative made upon a slow plate and showing sharp contrast between the lights and shadows.

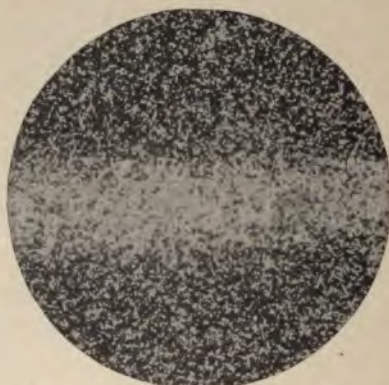

FIG. 58. Photomicrograph $\times 200$. Silver Deposit on a fairly Rapid Plate.

The hypothesis that the image is built up in some such manner receives support

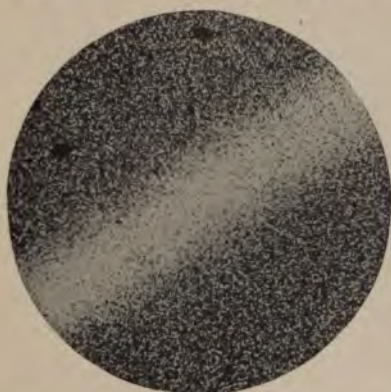

FIG. 59. Photomicrograph $\times 200$. Silver Deposit on a "Contrast" Plate.

Examined with a microscope, which need not be of very high power, the image is seen to be formed of grains or aggregates of silver, of irregular shape and size, but in general much smaller in slow plates than in rapid ones. Figure 57 is a photomicrograph of the structure of the deposit on a rapid plate. The object photographed was a fine black line on a sheet of white paper, appearing as a white line on the negative and in the picture as the ill-defined white path across the field. Figure 58 is a similar photomicrograph upon a plate of another kind and slightly slower, no material difference showing itself. Figure 59 is the same object photographed upon a slow "contrast" plate, of a kind made especially for such work; the borders of the line are better defined, and the deposit of silver is of much finer grain. Figure 60

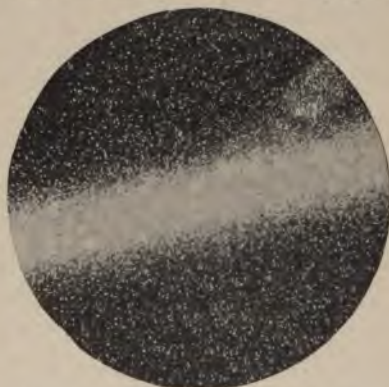

FIG. 60. Photomicrograph $\times 200$. Silver Deposit on a Lantern-slide Plate.

shows the same photograph upon a lantern-slide plate, which is of still finer grain than the contrast plate; the development in this case was carried beyond the usual point in order to show the blocking up of the spaces between the silver aggregates. The magnification in all four pictures is two hundred diameters.

Since for a satisfactory result the primary light-image must be reduced to metallic silver before the unaltered salt is attacked, the developing solution must not be too strong. Even suitable developing agents will produce fog if too concentrated. In cases of over-exposure, where the whole surface of the plate is more or less affected by the light, and a weak, flat image would be produced by normal developing, a restrainer is often employed, the most common substance being potassium bromide. It appears to promote the formation of double bromides which are less readily decomposed by the developer, and therefore lessen the rapidity of the reducing action, retarding the reduction of the less exposed portions of the plate more than the more exposed parts, and thus increasing the contrasts.

Just why the freshly reduced silver, in the presence of the developer, should react with the unaltered silver bromide has not been fully explained, but it is very probable that the action is one of electrolytic decomposition.

Characteristic Curves. — It may be laid down as an axiom that a negative is technically perfect when the intensity of the light transmitted through its gradations is inversely proportional to the intensity of light coming from corresponding regions of the object. It has been shown¹ that in such a

¹ HURTER AND DRIFFIELD, *Journal of the Society of Chemical Industries*, May 31, 1890.

negative the densities of the deposit are proportional to the logarithm of the corresponding exposure. If a series of plates of the same brand is given exposures increasing in geometrical progression (so that their logarithms increase in arithmetical progression), and all the plates are subjected to exactly the same process of development, the curve showing the relation between logarithm of exposure and density will have a form like that shown in Fig. 61. This curve, which is of the same general form for every kind of plate and

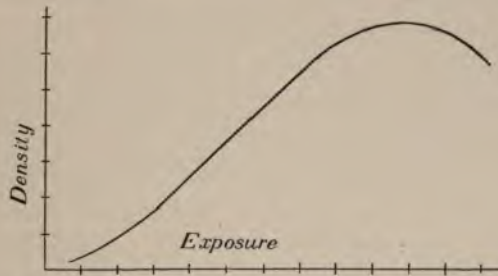

FIG. 61. Characteristic Curve of a Photographic Plate.

developer, consists of four parts, each having special significance. In the first portion, which is concave upward, the density increases with increasing exposure more rapidly than the condition of perfection requires. This is the region of under-exposure, where the contrasts of light and shadow are exaggerated. The second part of the curve is a straight line, and Hurter and Driffield proved that so long as the exposures lie within the limits defined by this straight portion the density of the deposit is in a high degree in accordance with the condition of theoretical perfection. This is therefore the region of correct exposure. In the next portion of the curve the densities increase less rapidly than the law requires, hence

contrasts are diminished by increasing exposure, up to the top of the curve, at which point increase of exposure fails to bring any increase of density whatever. This third part is the region of over-exposure. Finally, the downward-curving portion represents the region of reversal, in which increasing exposure actually diminishes the density of the deposit, so that ultimately the light and shadows are reversed, and the plate develops into a positive instead of a negative. This condition is easily brought about by exposures several hundred times as great as are required to give good negatives.

Other things being equal, the best plate is of course the one whose characteristic curve has the longest straight portion, and within this region there is therefore no one exposure which is better than any other, differences in exposure merely making the whole plate more or less dense without affecting the gradations. Differences between plates in this respect are commonly expressed by saying that certain plates have a greater *latitude of exposure* than others. Experiment has shown that plates with a thick layer of emulsion possess intrinsically a greater latitude than plates more thinly coated; and since the emulsion of very rapid plates is of necessity thinner and less rich in silver than that of slow plates, it follows that it is necessary to judge exposures more accurately when very rapid plates are used. Not only is the exposure more difficult to measure because of its shortness, particularly in outdoor work, but the latitude (the margin of permissible error in judgment) is less; and this applies also to the proper rendering of strong contrasts, a brightly lighted object not producing a correspondingly dense image. This is the chief reason for the well-known difficulty of the inexperienced worker with very rapid plates, and the reason

why slow plates always give more brilliant pictures. With rapid plates there is always more or less degradation of contrasts, assuming that the shadows of the picture have received sufficient exposure.

The conclusion of this argument is plain enough: slow plates should be used whenever possible in preference to rapid ones, if the original contrasts are to be preserved. Of course circumstances often will not permit the necessary length of exposure with a slow plate, and a rapid one must be used; but in many cases, in photographing well-lighted interiors, for example, the gain in brilliancy of the picture is well worth the few additional minutes of exposure. Should the slow plate give undesirable density in the lights of the picture, the persulphate reducer described below is an entirely satisfactory remedy.

Hurter and Driffield also showed by careful experiment that none of the usual variations in the strength or composition of the developer are able to alter the density ratios in the least; that is, the straight portion of the curve remains straight, and the curved portions curved, no matter how the developer is modified. For the straight portion of the curve at least, all the variations in the negatives that can be produced by changing the composition of the developer can be equally well obtained by altering the time of development or changing the temperature of the bath, or both.

This conclusion has been the subject of a vigorous controversy, the echoes of which have not yet died away, but its validity has never been disproved. It is unquestioned that an over-exposed or under-exposed plate can be treated so as to give a negative which bears a superficial resemblance to one obtained from a correct exposure; but a careful comparison

of the two will immediately show that, although the highest lights and deepest shadows may be the same in both, the intermediate gradations are very different, and decidedly faulty in the abnormally exposed plate. In other words, the common remedies for over-exposure and under-exposure are not really remedies at all, though by casual inspection they may seem to have accomplished the desired result.

Time Development. — From this experimentally demonstrated proposition, that modifying the developer will not remedy errors of exposure, it follows that everything obtainable can be secured by modifying the time of development; and that, given a standard developer and a definite temperature, properly exposed plates can be developed by the clock, without regard to the looks of the image as seen in the developing tray. This is the basis of the systems of time development, which are assuming considerable importance, and have been given wide exploitation by the introduction of developing machines and developing tanks.

Negatives thus obtained will differ among themselves in density, but the essential result is obtained of correct gradations in each, no matter what the average density may be over the whole plate. If it is too dense for satisfactory printing, it can be reduced; if too thin, it can be intensified. Individual treatment during development is not necessary.

Factorial Development. — There is another method of time development, which allows the photographer to use whatever developer he chooses, even if not made up in standard solutions. In this method¹ the time required for the image to make its appearance is taken as the unit, and development is continued for three, four, or more such units of

¹ WATKINS, *Journal of the Society of Arts* (London), Dec. 5, 1902.

time, as may be determined once for all by experiment with each kind of plate and developer used. In this procedure, also, no heed is given to the looks of the image, and any undue thinness or opacity is corrected afterward by intensification or reduction.

The arguments in favor of time development might be accepted without objection for the case of plates properly exposed, and still the system would fall far short of satisfaction unless it proved to be at least as good as the time-honored methods for the treatment of over-exposed and under-exposed plates. On this important point it can safely be said that the results obtained are at least not inferior to those obtainable by any other means. Further, apart from its merits as a whole, the system has emphasized the fact that over-exposure is really as incurable as under-exposure — contrary to the assertions of most handbooks, but recognized by every careful worker. All the recent investigations upon development lead to the very definite conclusion that correctness of exposure is absolutely essential to success. Pictures are made and lost in the exposure, not, as is so often asserted, in the developer. This raises the very pertinent question, then, how is the beginner to attain a knowledge of correct exposures, without an experience which may be as long and costly as it is discouraging?

Exposure Meters. — The eye is an entirely untrustworthy guide in estimating the exposure from the brightness of the image seen on the ground glass, and for many years exposure tables have been used as a help in determining exposure times. Their usefulness is unquestioned, but they leave a wide margin for the exercise of judgment. At the present time, however, there are on the market several types of ex-

posure meters, which give directly a measure of the photographic intensity of the light used. In use a slip of chemically prepared paper is exposed by the side of a second standard piece suitably tinted in permanent color for comparison. The light discolors the freshly exposed slip, and the time required for it to change to the standard tint is a measure of the photographic power of the illumination. Suitable scales supplied with or upon the instrument enable the user to reduce this time to minutes or seconds of exposure, without labor.

Exposure meters, however reliable, are not a substitute for experience, though they are of very great assistance. The readings of the exposure meter must be applied with judgment; taking into account, for example, the old and most satisfactory rule to expose for the shadows and let the lights take care of themselves. But the worker equipped with a good exposure meter and the courage to develop his plates as the theory of time development directs will not be seriously troubled with either over-exposure or under-exposure, except by accident or carelessness.

Developing Formulæ. — An essay on development would be incomplete without formulæ for developing baths. In general it is wise for the careful worker to make himself thoroughly familiar with the properties of a single developer, rather than to experiment unsystematically with half a dozen different ones. It is entirely safe to use the formulæ recommended by the plate maker, but not at all necessary, because a reliable developer may be used on any kind of plate, with few if any exceptions. A good developer must produce a minimum of fog, should not stain the plate or the operator's hands nor injure the skin, should not oxidize too rapidly by absorption from the air while in use, and should do its work

with reasonable (not too great) rapidity. Finally, if time development is not practiced, the developer should be capable of repeated use as a minor matter of convenience.

The following formulæ are given merely as examples of satisfactory developers, and are by no means intended to cover the whole field. The proportions are given in English and metric units. For photographic work it is quite accurate enough to consider 15 grains as equal to 1 gram, and 30 grams equal to 1 ounce.

HYDROQUINONE DEVELOPER.

Solution A.

Water,	8 oz.	350 c.c.
Sodium sulphite,	500 grains.	50 grams.
Sodium phosphate, (Na_2HPO_4),	120 grains.	12 grams.
Hydroquinone,	50 to 80 grains.	5 to 8 grams.
Eikonogen,	50 to 20 grains.	5 to 2 grams.

The total weight of hydroquinone and eikonogen together should be 100 grains (10 grams in the second column). Hydroquinone alone gives a brown image, eikonogen alone a bluish-black one, and the variable proportions afford a means of varying the color of the image between brown and black, if for any reason this is desirable.

Solution B.

Water,	8 oz.	350 c.c.
Sodium carbonate, crystals,	500 grains.	50 grams.
Sodium phosphate,	120 grains.	12 grams.

These solutions are to be kept in separate bottles, with sound corks, or better, soft rubber stoppers, which are airtight and easily removable. Solution B will keep indefinitely, and in a well-stoppered bottle A will keep at least a year. It

absorbs oxygen from the air slowly and darkens, losing its developing power in proportion to its oxidation.

For use take 1 part of *A*, 1 part of *B*, and 1 of water. The mixed developer may be used repeatedly until it has oxidized to a coffee color, and may be kept a long time in well-stoppered bottles that are completely filled. It will not stain the hands except by prolonged immersion. In using perfectly fresh solutions it is well to add a few drops of a 10 per cent solution of potassium bromide, to prevent a slight fog which may sometimes occur. With a solution which has been once used, or a solution replenished from the stock bottle, no fog will be produced.

FERROUS OXALATE DEVELOPER.

Solution *A*.

Potassium oxalate,	4 oz.	115 grams.
Water,	16 oz.	460 c.c.

Solution *B*.

Iron protosulphate,	4 oz.	115 grams.
Water,	12 oz.	345 c.c.
Citric acid,	15 drops.	15 drops.

Developer: pour 1 part of *B* into 4 parts of *A*, and add a few drops of a 10 per cent solution of potassium bromide.

Ferrous oxalate is not a satisfactory substance to deal with directly because of its slight solubility in water, and is best prepared in the manner above described. The reaction is as follows:



The first product is the developing agent, the second is inert and remains in solution in the developing bath. The active agent may be regarded as the potassio-ferrous oxalate of the

formula, or more simply, as ferrous oxalate, $\text{Fe}(\text{C}_2\text{O}_4)$, in a solution of potassium oxalate.

With most of the complex developing agents, the reactions which take place during development give rise to products of unknown composition; but with the ferrous oxalate developer the reactions may be represented as follows:

On the sub-haloid hypothesis, the first reaction taking place is

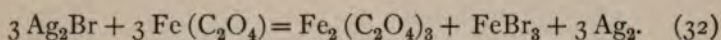

This is followed by

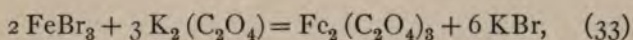

both the ferric oxalate and the potassium bromide thus formed remaining in solution.

The silver reduced as in (32) reacts with the unaltered silver as in (30), and with the help of more of the developer the image is built up as already described.

On the molecular strain hypothesis, equation (32) would be written as follows:

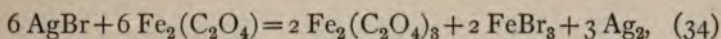

reaction (33) taking place as before.

The ferrous oxalate developer gives a beautiful blue-black image, of just the right color for lantern slides and transparencies. It has the advantage of being a perfectly definite and simple compound, and gives no fog; for which reasons it is very valuable for comparative studies of plates and quantitative work generally. It must be made up at the moment of use, as it oxidizes very quickly and loses its developing power. It is also necessary to wash the plate for a minute or

two after development is complete, and before putting it into the fixing bath.

Among the newer developing agents, none has found more favor than ortol, and the following formula will be found excellent:¹

ORTOL DEVELOPER.

Solution A.

Water,	20 oz.	250 c.c.
Potassium metabisulphite,	70 grains.	2 grams.
Ortol,	140 grains.	4 grams.

Solution B.

Water,	20 oz.	250 c.c.
Sodium carbonate, crystals,	2 oz.	25 grams.
Sodium sulphite, crystals,	1½ oz.	18½ grams.

Developer: 1 part of *A*, 1 part of *B*, and 1 part of water. If development is too rapid, add a small quantity of 10 per cent solution of potassium bromide, as needed.

Time Developer. — For time development it is necessary to have a standard developer, freshly made for each using. Ammonia and crystallized alkalies cannot be used, on account of the uncertain strength in the crystals due to a variable amount of water of crystallization; anhydrous salts are necessary. The following formula is recommended by the Eastman Kodak Company for use in their developing tanks:

Pyrogallol,	60 grains.	4 grams.
Water,	48 oz.	1440 c.c.
Sodium sulphite, anhydrous,	180 grains.	12 grams.
Sodium carbonate, anhydrous,	120 grains.	8 grams.

Add the pyrogallol after the other salts are dissolved. Develop for ten minutes at a temperature of 65° Fahrenheit.

¹ *British Journal of Photography*, Dec. 30, 1904.

A second plate may be developed in solution not needed for the first one, if development is begun within fifteen minutes after mixing. For development lasting twenty minutes, use twice the given quantity of water.

CHAPTER XI.

MARKINGS UPON THE PLATE.

FROM the preceding discussion it is seen that the normal action of the developer is concerned only with the existence of a small amount of altered silver bromide, and not at all with the way in which the alteration may have been produced. It therefore follows that any agent which will assist or retard the formation of this product will affect the density of the final deposit on the plate. If it is itself capable of effecting the alteration, or producing some change analogous to it, there will be produced an "image" wherever it has acted. If the effect is local, the result ranges from merely insignificant markings up to entire spoiling of the negative.

Developable impressions, as most workers know to their chagrin, are very easy to produce, without the smallest exposure of the plate to light. It is perhaps hardly fair to classify under the head of accidents the effects observed on old plates, for the careful photographer will not use old or stale plates where such effects would be harmful; and yet the markings observed are due to causes quite similar to those that bring the greatest annoyance in ordinary work. An old plate which is of the ordinary (not orthochromatic) kind will show when developed a black border whose width increases with the age of the plate, showing a deterioration which is due to the slow penetration of the acids of the air into the box. Orthochromatic plates show the same effect, com-

bined with a general fog which is caused by the decomposition of the dye itself. The latter is much more pronounced than the former, so that dyed plates cannot be preserved nearly as long as the undyed brands.

But the particular effects referred to in this chapter are local rather than general in their character. They can be produced in a great variety of ways. For example, as an illustration of a purely physical process producing a developable impression, if a part of the plate be subjected to considerable mechanical pressure, the pressure marks, invisible before development, may be easily developed into sharply defined black lines. It is an interesting and simple experiment to write upon a plate, with any kind of a smooth hard point, using care not to tear or scratch the film, and find the writing come out sharp and black by development. An electric discharge over the plate leaves an invisible trace that can be developed into a branching or tufted figure, often of great beauty in itself, but as a rule a source of much annoyance when it appears upon a negative desired for other purposes. It is very likely to appear on the "daylight" films now so much used, because the friction between the film and the black paper rolled up with it is almost certain to cause more or less electrification in dry weather. Dry gelatine and celluloid are very easily electrified, as may be shown by the following experiment. Having previously thoroughly dried an ordinary glass or film negative, rub the film side with a dry cloth or brush, or even with a dry finger, when it will be found that a sheet of paper will stick to either side. The celluloid film shows the effect better than the glass plate, and the experiment is more striking if the film is warm as well as dry. The practical bearing of this is that when so electrified the

surface of the plate attracts dust particles strongly, and that when plate and brush are very dry the common practice of dusting the plate with a brush before putting into the plate-holder is apt to result in the final presence of more dust particles than have been initially removed, unless the inside of the camera and holder are kept extremely free from dust.

Turning from purely physical causes to those of a chemical or debatable nature, experiment shows that a great variety of gases and vapors¹ are capable of producing similar developable effects. A freshly scratched or polished piece of zinc, allowed to remain in contact with a rapid plate for a day or two, will give a perfectly well defined "shadow" of itself when the plate is developed. Most photographers know that printers' ink will do the same, with a somewhat longer exposure; and the printed identification marks on the black paper of the daylight films already mentioned have an annoying habit of registering themselves in the same way, usually on the most conspicuous parts of the negative. A piece of clean fresh wood, after prolonged contact with a plate in the dark, will imprint its grain very distinctly. Figures 62 and 63, from untouched negatives, show the results obtained by a five weeks' exposure of this kind with blocks of hard pine. Similar results may be obtained with a great variety of substances, and it is not easy in many cases to fix upon the precise agent responsible. Dr. Russell, in the paper referred to in the footnote, ascribed most of the effects to the formation of hydrogen peroxide. With some substances, like bits of Welsbach mantles and certain minerals, it is clearly justifiable to ascribe the effects to radio-activity of the material; but until more is known about the nature of the action upon

¹RUSSELL, *Proceedings of the Royal Institution*, May 5, 1899.

the silver salt, the hypothesis of indiscriminate radio-activity should be rather sparingly used, unless supported by evidence from other lines of experiment.

A fragment of an unused Welsbach mantle, laid upon a rapid plate, will give a perfect copy of its texture on development of the plate after an exposure of several weeks in the dark, the necessary time depending on the amount of thorium in the mantle, which is largely a matter of price.

Though less common in ordinary work, the converse of the above effects may be produced; the latent image may be destroyed entirely, or at least rendered undevelopable. If the developer is denied access to any portion of the film, of course no image can be produced there, and the region thus treated will

be completely cleared in the fixing bath. The effect of finger marks, which are due to the natural oil of the skin, is

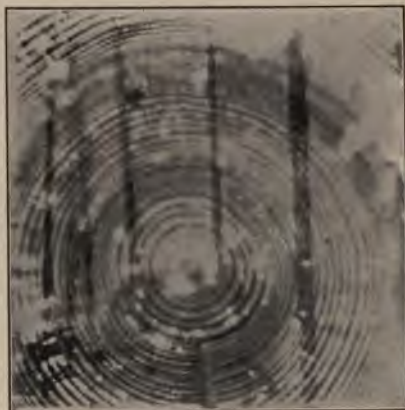

FIGS. 62 and 63. Effect of Emanations from Wood.

thus explained. On the chemical side, many gases and vapors, especially those which tend to prevent the liberation of bromine, act to lower the sensitiveness of the plate. If abundant, they may take away the sensitiveness of the plate entirely, or if applied after exposure they may destroy the latent image altogether, leaving nothing developable. An accidental illustration of this is shown in Fig. 62. The rather thin wooden block was tied to the plate by a cotton string wound about both plate and block to insure close contact; and emanations from the string have penetrated along the grain of the wood, producing the markings which are white on the plate and, of course, black on the print. A test showed the string to be strongly impregnated with hydrochloric acid.

CHAPTER XII.

FIXING, WASHING, AND DRYING.

WHEN the image has gained the proper density in all its parts, the work of the developer is finished; but the unreduced silver bromide is still sensitive to light, and must now be removed, of course without injury to the silver image. The problem of removal was a great stumbling-block in the way of the early workers in photography. In 1802, after describing a method of copying paintings or designs drawn on glass, Thomas Wedgwood wrote, in allusion to the lack of a fixing agent, "Nothing else is wanting to make the process as permanent as it is beautiful." In 1839 Fox Talbot obtained a partial fixation of prints on paper by the use of common salt.

The substance now commonly known as "hypo," or, more fully, sodium hyposulphite, is not the true hyposulphite — the salt of hyposulphurous acid — but is properly sodium thiosulphate. It is, however, rarely catalogued by dealers under its proper name. First made in 1799, it was known to Sir John Herschel in 1819, and its use by him as a fixing agent was described by Fox Talbot in a paper read in 1839. Although one or two other substances, notably potassium cyanide, will also act as fixing agents, the "hypo" salt is practically universally used for this purpose, except by the photo-engraver, as it is effective, not actively poisonous, conveniently handled, and now very cheap.

Fixing Bath. — As soon as development is complete, the plate should be removed from the developing tray, given a rinsing under the faucet, and then immersed in the fixing bath, which should be provided beforehand in ample bulk. This bath may be made up according to the formula of the plate maker; or the following, which is entirely satisfactory, may be used:

Hypo,	16 oz.	500 grams.
Water,	64 oz.	2000 c.c.
After the hypo is dissolved, add		
Sodium bisulphite solution,	1½ oz.	45 c.c.

The sodium bisulphite solution is made by dissolving one part of dry sodium bisulphite (sometimes called acid sulphite) in five parts of water. Its function is to keep the fixing bath clear and to prevent staining the plate, a plain hypo bath turning brown after one or two plates have been fixed in it, unless the developer is very thoroughly washed out beforehand. The acid bath may be used repeatedly until exhausted, this condition manifesting itself by very slow action.

If the hypo is present in restricted quantity, the action upon the plate is as follows:



This double thiosulphate is only slightly soluble in water, and its elimination from the film is a matter of difficulty; but by using a fixing bath containing a more liberal proportion of hypo the reaction is as follows:

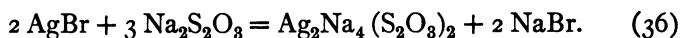

This double thiosulphate is readily soluble in water, and is easily washed out of the film with the sodium bromide. The

obvious conclusion is that the fixing bath should be of good strength. A one-to-four proportion is very satisfactory for plates; for prints it is a little too strong, and may cause blisters. There is little danger of getting the bath saturated, as the following table of solubility shows:

TABLE V. SOLUBILITY OF SODIUM THIOSULPHATE.

One hundred parts of water will dissolve
65 parts at 16° Centigrade.
69 parts at 20°
75 parts at 25°
82 parts at 30°
89 parts at 35°
98 parts at 40°
109 parts at 45°
114 parts at 47°

Authorities differ on the solubility at the higher temperatures.

The time required for fixing depends somewhat on the temperature of the bath and its strength, but much more on the thickness of the gelatine film. Thin films, like those of lantern-slide plates, fix out in two or three minutes, while double-coated or triple-coated "non-halation" plates are so slow in fixing as often to raise the suspicion that the fixing bath has become exhausted. It is generally recommended to leave the plate in the bath for twice the time required to cause the disappearance of the whiteness of the film as seen from the back of the plate, but this is longer than is really necessary. Four or five minutes after the white has disappeared is ordinarily ample to secure complete fixation. It should not be forgotten that a strong solution of hypo exercises a slight solvent

action upon the silver, and that a plate left for an excessive time in the fixing bath will be somewhat reduced.

If a number of plates is treated at the same time, a fixing tank is a great convenience. This is merely a hard rubber box with grooved sides, into which the plates may be slid vertically and kept out of contact with each other. A closely fitting cover keeps the bath from evaporating when not in use, and allows white light to be used in the dark room as soon as the last plate has been immersed.

In hot weather, or when the temperature of the developing bath is above 70° Fahrenheit, plates are apt to frill at the edges, a condition sometimes aggravated to a serious degree in the fixing bath. In such cases it is necessary to allow the plate to lie for a few minutes in a saturated solution of common alum after development, rinsing it again before fixing. It is also permissible to add an alum, preferably chrome alum, directly to the fixing bath, each plate manufacturer having his own formula. A 5 per cent solution of formaldehyde may also be used. Unless absolutely necessary, however, it is better to omit the hardening bath, as its action on the gelatine makes the elimination of the salts more difficult in the final washing.

Washing. — After fixing the image, all soluble matter must be removed from the film by thorough washing. Insufficient washing leaves hypo and silver thiosulphates in the film, which crystallize, turn brown, and destroy the image. Washing is really more a matter of time than quantity of water. Where running water cannot be had, it is quite possible to eliminate the hypo by giving the plate a thorough rinsing after fixing and then allowing it to soak for an hour in a tray of clean water, changing the water six or eight times. The preliminary rinsing, which should be given in any case, is materially

aided by swabbing the film surface lightly with a wad of absorbent cotton.

When running water is available, the simplest method of washing is to lay the plates in a tray, film upwards, and to allow a stream of water to flow over them. This is efficacious; but if the water contains any sand, the particles will be deposited on the film and cannot easily be removed. A better way is to use a washing box, which is made like the fixing tank just described, except that it has a pipe leading into the bottom and is arranged to cause a gentle current of water to flow upward past the plates. Except for multiple-coated plates, twenty minutes to half an hour in such an apparatus is enough to insure thorough washing. It may interest the tourist to know that salt water can be used for washing out the hypo and silver compounds from the film, except that a final soaking in fresh water is necessary to remove the salt.

It is not always possible to be sure that a sufficient washing has been given, and a hypo test may occasionally be useful. The following test (Abney) belongs rather to the photographic laboratory than to the tourist's outfit, but is useful for testing suspected plates or prints. A piece of starch as big as a pea should be boiled in one-third ounce (10 c.c.) of water until the solution is clear. The addition to this liquid of a few drops of a solution of iodine in alcohol will produce an intensely blue liquid, a very little of which will impart a distinct blue tinge to a test tube or clear glass tumbler of water. The suspected plate or print should be thoroughly wetted with as little water as possible, and some of the water allowed to drip into the faintly colored starch solution. The presence of enough hypo to make further washing necessary will be shown by the instant disappearance of the blue color. The test is

best made in a long test tube with a sheet of white paper placed beneath it, so that the tube may be viewed endwise, a similar tube of clean water being put beside it for comparison.

Drying. — After washing, the plates should be removed from the washing box or tray, rinsed, and swabbed once more under the tap, to remove particles of adherent solid matter, and set on edge to dry. Convenient drying racks are sold, costing a few cents each, and holding from twelve to twenty-four plates. These hold the plate without danger of slipping or breaking, and at the same time allow it to drain freely. The drying process may be allowed to go on spontaneously, or if necessary may be shortened by artificial means. A negative will take from one hour to twelve hours to dry of itself, according to its size and thickness of film and the state of the atmosphere, but if it is exposed to a current of air, it will dry much more quickly, particularly if the air is slightly warmed. An electric fan is a most valuable auxiliary when time is limited.

Drying by Alcohol. — It is also possible to hasten the drying by the use of alcohol. After draining for a minute, the plate may be immersed in a porcelain tray of strong alcohol. The alcohol penetrates the gelatine film and a part of the water passes out into the mass of alcohol in the tray. When the diffusion of water and alcohol is complete, the plate may be taken out and dried by swinging it in the air or exposing it to a draught as already described. This operation takes a very few minutes, but is not recommended for valuable negatives, as a large film is apt to pucker from irregular drying unless the process is very carefully managed.

Drying by Formalin. — A still more energetic method is to soak the plate for a few minutes in a 5 per cent solution of

formaldehyde and then to dry it by heat. Without the formaldehyde bath the gelatine will melt when heated, but the bath renders it insoluble and able to bear heat without softening.

It should also be noticed that the drying, in whatever way it is effected, should be at a uniform rate. A rapidly dried plate is less dense than one slowly dried; so that if part of a plate is dried at a slow rate and the rest dried quickly, a distinct line will show at the boundary of the two regions, which will appear upon the finished picture.

After drying, the film should be perfectly smooth to the touch. If it is not, either the washing water contained grit or there is still hypo in the film. Plates washed in an upright position are always smoother to the touch than those washed in trays, unless the water is unusually free from solid matter.

little gain in opacity. It is best to allow the bleaching solution to act to its fullest extent; to stop short of complete whitening appears to hasten the subsequent deterioration of the image.

The next step in the process is to remove the mercuric chloride of the original solution as completely as possible. The salt hardens or "tans" the film, and an hour's washing is necessary, with twice as much for thick films.

To get the required opacity the salts in the film must now be blackened, and this may be accomplished in various ways. Immersion of the plate in a 10 per cent solution of sodium sulphite is sometimes practiced, and gives a deposit considerably denser than the original image. Or, the plate may be redeveloped, preferably with the ferrous oxalate developer, giving a result still more intense, and perhaps more permanent. But the greatest degree of intensification is obtained by using dilute ammonia as the blackening agent, and this is the method most commonly employed. Instead of ammonia, ammonium sulphide may be employed, but this substance is not usually found in the photographer's cabinet. After a third and final washing, the intensifying process is complete and the plates are ready for the drying rack.

The chemistry of the above processes is fairly well understood. The sodium sulphite reduces the chlorides of equation (37) to the metallic state in part, the reaction being probably as follows:

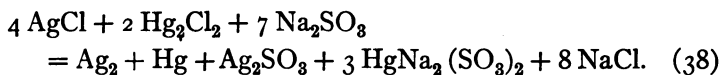

Development by ferrous oxalate reduces both chlorides completely to the metallic state. The reactions may be stated separately:

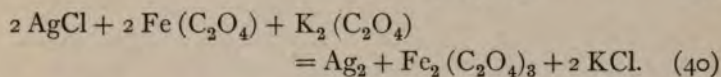
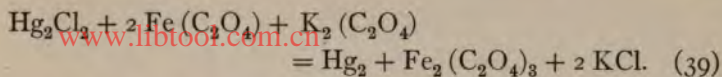

In this case, since the image is restored in silver with the addition of mercury, the process may be repeated if desirable, with an additional gain in intensity.

With ammonia, the action upon the mercurous chloride is as follows:

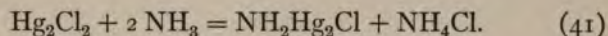

The first product is insoluble and forms the image; the second, ammonium chloride, is readily soluble in water, and the silver chloride left over from equation (37) also dissolves in the ammonia bath. Both are therefore carried off in the washing water, leaving the image composed of the black mercurous-ammonium chloride. Recent studies have shown the presence of silver in the black compound, and probable reactions are as follows:

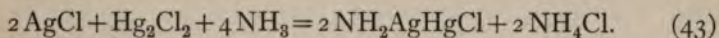
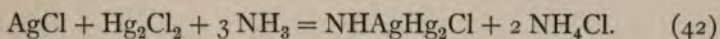

It is fairly certain that both the mercurous-ammonium and several mercurous-silver-ammonium chlorides are formed.¹

When ammonium sulphide is used, the metallic chlorides are converted into sulphides:

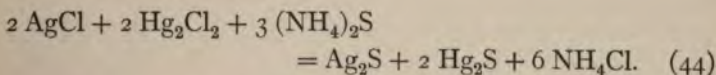

¹NOVAK, Eder's *Jahrbuch der Photographie*, 1901.

In all the above cases the silver molecule of the original deposit is either replaced by a more complex one, or has another molecule of mercury or mercurous compound added to it. There is an enlargement of the size of the silver aggregates in the film, as may be plainly seen in the accompanying photomicrographs.

An opaque sheet of metal, perforated with very small holes of uniform size, was photographed against a bright background, the negative therefore

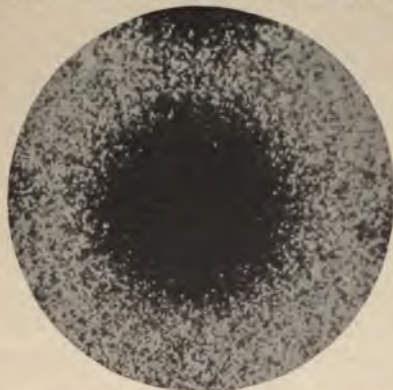

FIG. 65. Photomicrograph $\times 200$. Intensification with Mercury and Sodium Sulphite.

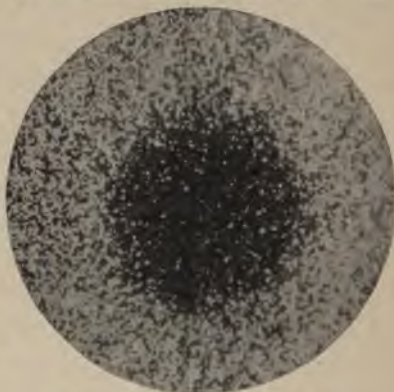

FIG. 64. Photomicrograph $\times 200$. Untouched Negative.

showing black dots on a white background. Different portions of the negative were then treated with different intensifiers and photographed under the microscope, with a magnification of two hundred diameters. Figure 64 shows the appearance of the untouched parts of the negative, from which the size of

the original particles may be estimated.

Figure 65 shows the result of intensifying with sodium

sulphite. In all four pictures the boundary of the field represents a circle 0.01 inch in diameter on the original plate.

Figure 66 gives the appearance of the deposit when the bleached image is redeveloped, thus adding mercury to the silver of the original image.

Finally, Fig. 67 shows the considerable enlargement in the size of the image-particles when ammonia is used as the blackening agent, and incidentally the encroachment of the image upon the neighboring parts of the plate.

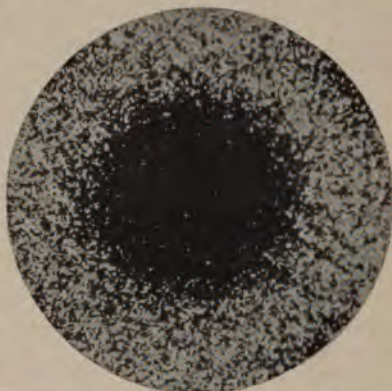

FIG. 66. Photomicrograph $\times 200$. Intensification with Mercury, and Redevelopment.

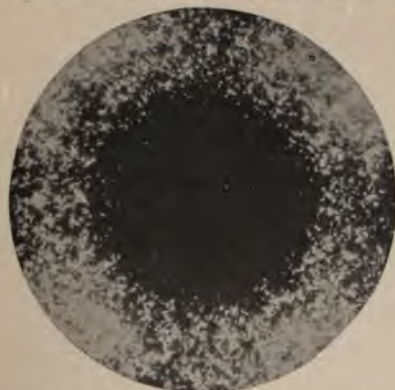

FIG. 67. Photomicrograph $\times 200$. Intensification with Mercury and Ammonia.

enlargements should not be intensified, especially if they contain fine lines or dots.

The dark regions at the edges of the field are the borders of the images of adjacent dots, which have increased in size like the one shown. Comparison of Figs. 64 and 67 shows the considerable change in the outlines of the image by intensification, and indicates plainly that negatives intended for critically sharp

It is possible to reduce an over-intensified negative by immersion in a weak solution of hypo, after which the inevitable washing must be given. In passing, it should be remarked that a negative which is to be reduced or intensified should not be alumed if it is possible to avoid it, for after the alum bath it is very difficult to eliminate undesired compounds from the film.

Uranium Intensifier. — All of the above methods are open to the objection that two operations are necessary, and that it is difficult to judge the final result until too late to change it easily. For this reason one-solution intensifiers are sometimes preferable. One of the best of these is the following:¹

Make up these solutions :

<i>A.</i>	Water,	8 oz.	320 c.c.
	Uranium nitrate,	$\frac{3}{4}$ oz.	30 grams.
	Nitric acid, c. p.,	$\frac{1}{4}$ oz.	10 c.c.
<i>B.</i>	Water,	8 oz.	320 c.c.
	Potassium ferricyanide,	$\frac{1}{2}$ oz.	20 grams.

For use mix 1 part of *A*, 1 part of *B*, and 32 parts of water. Immerse the negative in the solution and keep the tray in motion. Silver and uranium ferricyanides are formed, and the image soon assumes a deep brown or red color, whose printing density is easily underestimated. A little intensification will affect the printing qualities of a negative considerably, and on this account it is wise to experiment first upon a few valueless negatives. However, should the intensification have gone too far, it may be reduced or even removed entirely by bathing the plate in dilute ammonia.

This intensifier is more convenient than the others men-

¹CRAMER, "Manual of Negative Making."

tioned, because it is in one solution. It is also very powerful, and may be used with good effect upon negatives which are too thin to be sufficiently intensified by the mercury process. Further, intensification over portions of the plate can be obtained by first intensifying the whole plate, and then removing the intensification from the too dense places with a camel's-hair brush dipped in dilute ammonia. In this way it is often possible to obtain a great improvement in the printing density of the negative.

Permanence of Intensified Image. — This question has been much discussed, and any one taking the ground that intensification processes lead to deterioration of the image is sure to bring upon himself the criticism that his work has been carelessly performed and his plates insufficiently washed. Yet in the face of this criticism some of the most careful workers assert their conviction that intensified images are at best of uncertain permanence. There appears to be little evidence of deterioration of an image composed of metallic silver embedded in clean, dry gelatine. The prescription for permanence is simple: complete fixation must take place, followed by the entire removal of hypo and silver thiosulphates from the film; and the plate after drying must not be exposed to moisture or fumes. So-called hypo eliminators are obtainable from every dealer, but the only really efficacious hypo eliminator known is clean water.

But the prediction of permanence cannot safely be made when the silver image is loaded with mercury or displaced entirely by it or the other metals commonly used in intensifying processes. In the first place, it is very difficult to wash the hardened gelatine free from the chemicals used, or their by-products, and everything of the kind that is allowed to remain

becomes a source of ultimate trouble. Secondly, the final image, whether metallic or not, is of more complex composition than the original silver molecule, and is more readily attacked, both from without and from within the film. The testimony of many careful workers is to the effect that after a term of years intensified plates are apt to show a deterioration which cannot fairly be attributed to slovenly manipulation.

Reduction. — In photography, this has nothing to do with the chemical process of deoxidation; the term is applied to processes which remove a part or all of the silver image from the plate, and it is thus the converse of intensification. It is often necessary, and always desirable when the silver deposit is so dense that the resulting opacity is too great. This condition may arise from incorrect exposure or development, or from a very great contrast of light and shadow in the scene photographed.

A reducing agent may act in three ways:

(a) By removing more silver from the thin portions of the image than from the dense portions.

(b) By removing equal quantities from equal areas of the plate, irrespective of the original density of the deposit.

(c) By removing more silver from the denser than from the lighter portions.

The effect of a reducer acting in the first-named way will clearly be to increase the printing contrast in the negative, for the thinner portions will lose density and become transparent faster than the more opaque regions. Also, a reducer acting in the second way will tend to increase contrast, and will alter the density ratios, as may be seen from the following:

Let Fig. 68 represent a negative on different regions of which the silver is deposited in quantity represented by the numbers 4, 8, and 12, as shown by the piles of blocks *A*, *B*, *C*, the ratio of thickness of the deposits being therefore 1:2:3.

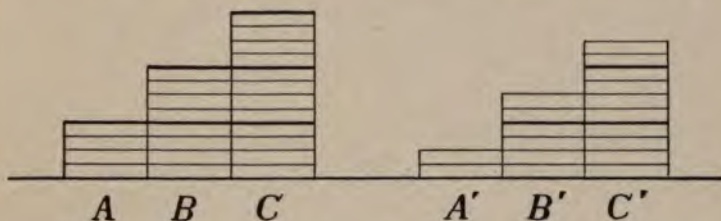

FIG. 68. Alteration of Density Ratios by Reduction.

Now if unit thickness of a medium transmits a fraction k of the light I falling upon it, it can easily be shown that the portion x of the incident light I transmitted through a layer m units thick can be represented by the equation

$$x = Ik^m. \quad (45)$$

The fraction k is called the coefficient of transmission.

For the sake of concreteness let the thickness of the four-block layer *A* in Fig. 68 be taken as unity, and suppose it to absorb 10 per cent of the light falling upon it; *i.e.*, let $k = 0.90$. Then layer *A* will transmit 90 per cent of the incident light, *B* will transmit 81 per cent, and *C* 72 per cent. In other words, *B* will transmit 1.11 times as much as *C*, and *A* will transmit 1.37 times as much as *C*. The relative times required to print *A*, *B*, and *C* to the same density will therefore be in the ratio 1:1.11:1.37.

Now, let a reducer be applied to the plate which shall remove a layer two blocks thick from each part of the original deposit

as shown in A' , B' , and C' . The relative thickness of the layers remaining is then in the ratio 1 : 3 : 5, and the relative intensity of the light transmitted through them, in terms of the thinnest as unity, will be 1 for A' , 0.729 for B' , and 0.590 for C' . That is, B' will transmit 1.23 times as much light as C' , and A' will transmit 1.69 times as much light as C' . The relative times required to print the three to equal density will then be 1 : 1.23 : 1.69.

On comparing this with the former result, it is clear the density ratios have been altered, and in the direction of increasing contrast. In the calculation the value of k has been taken high to illustrate a particular case; if it is taken lower, say 0.50, the relative times for printing change from 1 : 4 : 9 to 1 : 9 : 25, a much greater contrast. This is the explanation of the effect observed by intensification; a decrease in the coefficient of transmission is seen to be all that is necessary to bring about the observed results. The decrease in the coefficient might be accomplished by either an increase in the opacity of the individual particles, or by an increase in their size as they lie scattered through the film. Figures 64 to 67 show that the latter is the case.

From the preceding argument it follows that a reducer must remove silver from the image in such a way as to leave the density ratios unaltered, if the original contrasts are to be preserved in the print, and that its action in that case must be proportional to the quantity of silver originally present at any point. The result of the action would then be merely to reduce the time required for printing from the negative, without affecting the gradations of the print in the least. Such reduction would save time in making a large number of prints from a very dense negative, but would have no other advan-

tage. When, therefore, increased contrast is wanted for any reason, the reducer must act along the lines of (*a*) or (*b*); when reduced contrasts are desired, the reducer must act according to the principle of (*c*) in general, but removing an amount of silver from the dense portions of the image not only actually, but proportionately, greater than the amount taken from the lighter parts.

Farmer Reducer. —The formula for this was given by Howard Farmer in 1884. It acts more quickly upon the lighter than the denser parts of the image, and therefore increases contrast. It can be applied after the plate has been washed and dried, but the best time is immediately after the hypo bath. The method of application is very simple. To the requisite quantity of water enough potassium ferricyanide should be added to give the solution a lemon-yellow color. About 1 per cent of the salt will be required, the quantity depending on the kind of plate and the rapidity of action desired. The plate should be transferred directly to the ferricyanide solution from the hypo bath, without washing, and allowed to remain until the desired reduction has taken place. Rocking the tray will prevent irregular reduction, and rinsing the plate every time before holding it up for inspection is necessary to prevent streaks. Should the action stop before the desired reduction has taken place, the plate may be freshly charged with hypo by laying it for a minute again in the hypo bath.

If the plate to be reduced is one that has been washed and dried, it is first necessary to wet the film thoroughly, and then to immerse it in a fresh 1 to 4 hypo bath, tinted with the ferricyanide as described. This mixture is very unstable. It decomposes in a few minutes, changing from yellow to

brown and then to blue, when its reducing power is gone and a fresh bath must be prepared.

The action on the plate may be represented as in the following equation :

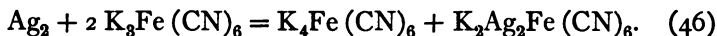

The first product, potassium ferrocyanide, is soluble in water; and the second, potassium-silver ferrocyanide, dissolves in the hypo solution.

As soon as the reduction has gone far enough the plate must be transferred to the washing box and thoroughly washed. The action is apt to continue for a little time in the washing water, if the solutions used have been strong, so that it is well to stop just before the desired result seems to have been reached. It should be remembered that rapid plates, having a much coarser grain than slow ones, can be treated without fear with solutions strong enough to destroy a fine-grained image almost instantly.

Ferric Chloride Reducer. — This acts quite evenly on the silver deposit, removing approximately equal amounts from both the denser and lighter portions. It is made up as follows:

Water, 60 parts.
 Ferric chloride, 1 part.
 Hydrochloric acid, 2 parts.

The negative needs only a rinsing after the hypo bath, followed by immersion in the solution. The reduction depends on the time of immersion and the strength of the ferric chloride bath. A rinsing, followed by the hypo bath again and a second washing, completes the process.

Ammonium Persulphate Reducer. — It is often important to reduce the denser portions of the image without affecting the lighter parts, and a reducer of the class (c) is necessary. Such a substance, sought for many years, seems at last to have been found in ammonium persulphate, which was first used for this purpose by the Messrs. Lumière and Seyewetz in 1898. Like the others, it is very simple in application. The two following baths are needed:

1. Water, 5 parts.
Sodium sulphite, 1 part.
2. Water, 100 parts.
Ammonium persulphate, 1 to 3 parts.

The strength of the persulphate bath should vary with the rapidity of action desired and the strength of the salt itself, which does not keep very well, even in the dry form. The plate is rocked in the persulphate solution until the reduction has progressed as far as desired. It will be found that the lighter portions of the image are affected very little, while the denser deposits are quickly reduced, the action depending only on the strength of the persulphate solution. There is no inherent objection to the use of solutions stronger than 3 per cent, except the difficulty of stopping the action at the desired point.

The instant the image assumes the desired appearance, the plate must be transferred to the sulphite bath, there to remain for five or ten minutes. This stops the reducing action. Afterwards, the usual washing must be given. If the sulphite bath is omitted the reduction will continue during the washing, and the image may almost entirely disappear.

From the action which takes place when the Farmer reducer

is used, it might be expected that the rapidity of its action would depend on the size of the silver particles attacked; the smallest disappearing first, just as small crystals of salt or sugar dissolve sooner than large ones when shaken up in water. This is confirmed by the fact already mentioned, that a Farmer solution which will clear a fine-grained image with destructive rapidity will act but slowly on a rapid (coarse-grained) plate. The result thus presents no apparent difficulty of explanation. The action of the persulphate reducer, however, is quite different and not yet understood. Its curious power of attacking the denser deposits formed of large silver aggregates in preference to the lighter areas of smaller and more scattered particles has received no satisfactory explanation, no theory yet put forward being able to stand the test of critical

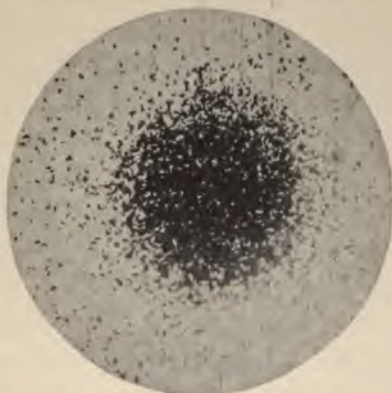

FIG. 69. Action of Ferricyanide Reducer.

experiment. Irregularities in the action of the salt have been found, but they appear to be due to the fact that the solution slowly decomposes, becoming more acid as it ages and acting more quickly in consequence. To insure uniform results, it is therefore only necessary to make a fresh bath for each time of use.

Though the manipulation is simple, stains with the persulphate reducer are not unknown. They may arise from the use of a fixing bath that is exhausted or too dilute, insufficient elimination of the hypo from the film before the reducer is

applied, or from too strong or too acid a persulphate solution.

The difference between the action of the Farmer and the persulphate reducer can be seen in Figs. 69 and 70, which represent the action of the two on a silver deposit like that of Fig. 64, page 156. Figure 69 shows the effect of the Farmer reducer; the smaller grains of silver have almost entirely disappeared, and only the larger ones are left. In Fig. 70 the effect of the persulphate reducer is shown. The smaller aggregates are almost unharmed, while the dense deposit has been cut away considerably, with a great reduction of contrast in consequence.

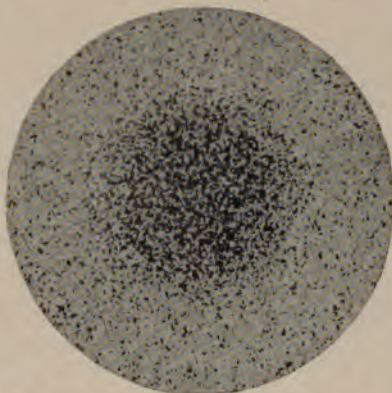

FIG. 70. Action of Persulphate Reducer.

With one or the other of the above reducers, acting as they do in such very different ways, it is possible to make a decided improvement in the printing quality of almost every negative, even though it may appear quite satisfactory as it comes from the fixing bath. Fog may be partly or sometimes wholly removed without injury to the image, the flat appearance of a landscape lighted from an unfavorable angle may be bettered, the intense contrasts of lighting in interiors can be toned down, and so on, to the immense improvement of the final picture. The permanence of the image is not called into question as with intensifiers, for the only effect of the reducer

is to take away a part of the silver without leaving in its place anything to give opportunity for subsequent harmful action.

The choice of the reducer to be employed depends on the negative to be treated. Negatives requiring such treatment may be divided into four classes: (*a*) those partly fogged in developing, (*b*) over-developed negatives, (*c*) under-exposed, normally developed negatives, (*d*) over-exposed and over-developed negatives. Class (*a*) needs merely the removal of fog, hence the ferric chloride or some similar reducer should be employed; classes (*b*) and (*c*) require the reduction of contrast, and the persulphate reducer should be used accordingly; class (*d*) needs increased contrast, so that the Farmer reducer is most suitable.

Reduction with Alcohol. — Another method of reduction deserves mention, but is best employed where only small areas are involved, such as a small or distant window showing in an interior view. If a wad of chamois leather wet with absolute (water-free) alcohol be rubbed over the spot to be treated, the silver can be rubbed away, somewhat as a pencil mark on paper yields to an eraser, though not quite as readily. The alcohol seems merely to toughen the gelatine sufficiently to enable it to withstand the rubbing process without tearing. The rubbing may be vigorous to a surprising degree without injury to the film, provided only that the gelatine is thoroughly dry and the alcohol free from water. It is not necessary to confine the rubbing too closely to the particular spot; the chamois pad may overrun the edges without harm. It is possible to hasten the process somewhat with a little tripoli powder as an abrasive, though when this is used the rubbing should be confined to the area to be reduced.

To Destroy the Image.— It is sometimes desirable to remove the image entirely from a portion of the plate. A strong Farmer solution can be used, but may leave a slight yellow stain, and the following is perhaps preferable:

Solution *A*.

Alcohol, 10 parts.

Iodine, 1 part.

Solution *B*.

Water, 100 parts.

Potassium cyanide, 10 parts.

Take a portion of *B* and dilute it to ten times its bulk with water. Pour a little of *A* into it and shake until the color disappears. Continue the addition of *A* until the color just refuses to disappear, when the clearness of the solution can be restored by a drop of *B* again. This final solution will clear off the image admirably. It must be borne in mind that potassium cyanide is a violent poison, and must be handled with extreme caution. It may here be also remarked that mercuric chloride and many of the developing agents in common use are poisonous, and that glassware and dishes used for photographic purposes cannot be diverted to other uses without risk.

CHAPTER XIV.

HALATION AND REVERSAL.

WHENEVER a brightly illuminated surface is crossed by dark lines, like those of branches of trees against the sky, the silver deposit representing the image of the bright surface spreads into the dark spaces, and if the lines are thin, they may be obliterated entirely. This is in a small measure due to the lateral spreading of the image in the building-up process of development, but chiefly to the scattering of light by reflection from the illuminated particles of silver bromide to their neighbors, and by reflection of light from the back of the plate. The effect of the whole is known as *halation*, but the last-mentioned factor is the most important part of it.

The cause of halation can be explained by the help of Fig. 71, which represents a section of a photographic plate, with light focused upon an exaggerated particle of silver bromide in the film. The rays producing the photographic action on the particle are of course absorbed, and go no farther; but a portion at least of the light falling upon the particle will be reflected from it in different directions. That which strikes the neighboring particles will affect them, causing some of the lateral spreading mentioned in the preceding paragraph; but a portion will take paths through the film represented by *ab* and *de*, reaching the back of the plate at the points *b* and *e*. At points like *b* the light is partly reflected and partly

refracted, the reflected and refracted rays taking the directions *bg* and *bc* respectively. The ray *bc*, having passed out of the plate, has no further effect; but the ray *bg* again enters the gelatine, and if intense enough will affect any silver bromide particles it encounters.

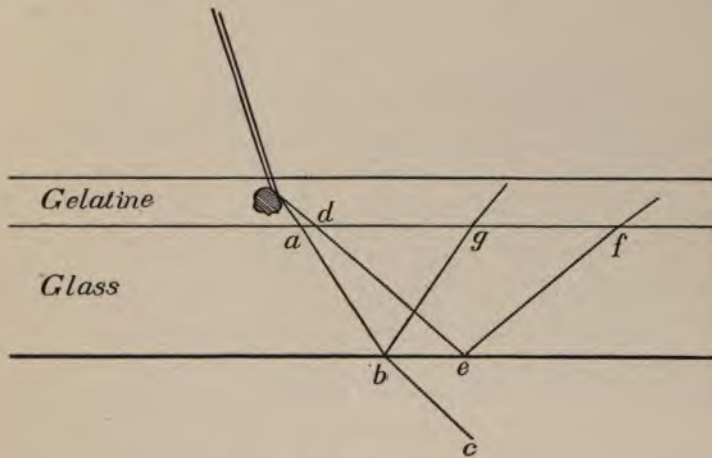

FIG. 71. Cause of Halation.

When the ray *ab* is nearly perpendicular to the surface of the plate, the reflected ray has very slight intensity, and very little effect is producible by it; but the percentage reflected increases rapidly in the neighborhood of the critical angle,¹ so that, if *de* represents a ray falling upon the surface at the critical angle, the reflected ray *ef*, which contains all of the light-energy of *de*, will be much more intense than the ray *bg*, containing only a part of the light-energy of *ab*. Thus it is easily possible to have a silver bromide particle at *j*

¹ The angle at and beyond which reflection of all the incident light occurs, no light being refracted out of the glass.

sufficiently affected to give a developable image, while other particles nearer the original reflecting particle may not be. This effect will be produced on all sides of the original particle, with the result that the bright focus will be surrounded by a luminous ring or halo, separated by an unlighted space from the bright central image. It is shown in Fig. 72, which

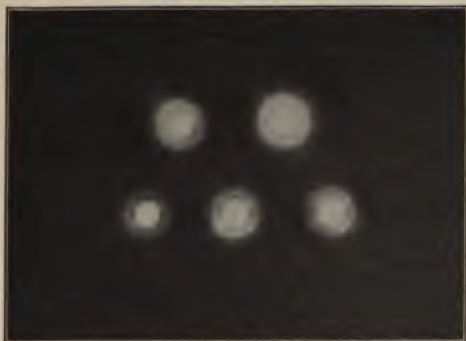

FIG. 72. Halation Circles.

is a photograph of several small bright circles. It is particularly noticeable in pictures taken at night, where distant lamps appear in the field of view. Since it is produced by reflection from the back

of the photographic plate, of course the rings do not show on the ground glass.

With a knowledge of the cause, the remedy for halation is simple. It is merely to prevent the reflection from the back of the plate, which can be done either by suppressing the incident ray or by preventing the reflection. Making the plate of less transparent material would be an effective remedy were it not that transparency is essential for printing purposes; but there is one ingenious and effective method, used by the Cramer Dry Plate Company, for accomplishing the result practically in the same way, without the disadvantage of permanent lack of transparency. All dry plates have the glass coated first with a thin layer of sizing of some kind, to increase the

adhesion of the gelatine to the glass; and the Cramer Company simply stains this film with a yellow dye which effectually prevents the passage of enough actinic light to do any harm. The alkali of the developer changes the yellow to a greenish color, which washes out in the washing box, leaving the film without color and of unimpaired printing rapidity.

By taking advantage of the physical principle that there is no reflection except where there is a change of refractive index, it is possible to suppress the reflected ray by the device of coating the back of the plate with an opaque material whose index of refraction is the same as that of the glass, or nearly so. This has the effect, as it were, of leading the rays out of the glass and then by absorption preventing them from getting back. Such plates are stocked by dealers under the name of "backed" or "non-halation" plates. The coating is of such a nature as to be easily washed off under the faucet before the plate is put into the developer.

A thick film is of course less transparent than a thin one, and several brands of non-halation plates owe their effectiveness chiefly to this feature. It is customary to coat such plates first with a slow emulsion, then with a rapid one, and, for extreme cases, sometimes with a third. With such a multiple-coated plate the light that will give a greatly overexposed image on the rapid film will penetrate into the slower one and produce an image of the proper density, while details of the less illuminated portions will be recorded upon the rapid film without affecting the slow one. The plates have an immense latitude, and are very useful for extreme contrasts of light and shadow; but they are expensive, and the superposition of the films makes them rather difficult to manipulate and very slow in fixing and washing.

Finally, since the diameter of the halation circle depends on the thickness of the plate, it might be supposed that if the plate had no thickness the incident and reflected rays would not be separated by a perceptible interval; and this is the case. Celluloid films show no visible halation, and for this reason are often successful in obtaining pictures where an ordinary glass plate would fail entirely.

The lateral spreading of the image can best be removed by local reduction with alcohol if the area is small, or by the ferricyanide reducer if it is large. In the latter case, care must be taken to confine the reducing solution to the area to be reduced, or irremediable streaks will be caused on the plate. In the effort to avoid halation many landscape and forest scenes are underexposed, though the outlines that disappear in a fully exposed plate can easily be recovered by the proper application of a reducer.

Reversal. — When the effect of increasing exposure is studied, it is seen that beyond a certain point, varying with the kind of plate used, increase of exposure fails to bring a corresponding increase of density, as was shown by the form of the characteristic curve, page 129. This point, then, marks the beginning of the period of over-exposure, which may be continued to the point where increase of exposure absolutely fails to produce further increase of density. Now, if the exposure is still further increased, a reversal of the preceding action takes place, and the action of the light is to produce a less readily developable impression, so that the image is weaker than before; and this may be continued to the point of complete reversal, the plate developing as a positive instead of a negative. It is an easy matter to produce this result by giving a brightly lighted landscape an exposure of several

minutes, for conditions under which the normal exposure would be a second or less, developing the plate in the usual way. Instead of a clean, sharp negative, a thin and rather indifferent positive will appear.

This phenomenon of reversal, or *solarization* as it is sometimes called, has been extensively studied, but no satisfactory explanation of it has thus far been given. It is facilitated by a preliminary exposure of the plate to weak white light, also by the use of energetic developing agents and by allowing an oxidizing agent to act upon the plate before exposure. Atmospheric oxygen seems also to play an important part in the process. It has further been observed that the phenomenon is of a recurrent nature, the steps in the cycle being as follows:

1. Normal negative.
2. Uniformly dense deposit (fogged negative).
3. Reversed negative.
4. Uniform light tint (slightly fogged plate).
5. Negative.

These stages may all be observed by photographing the sun, beginning with the shortest exposure and smallest stop of the lens, and making a number of exposures of increasing length. To produce the second negative stage it is necessary to give the plate something like 100,000 times the normal exposure, so that a very bright object is required for making experiments.

CHAPTER XV.

CERTAIN PRINTING PROCESSES.

WITH the silver salts, except in the daguerreotype and kindred processes, and indeed with nearly all light-sensitive substances, photographic processes give, not positives, but *negatives*; that is, images in which the lights and shadows are reversed. The final picture must therefore be obtained by a reversal of the negative image by light-action through the negative upon a second sensitive surface; and this process is called *printing*. The fact that the primary process gives a negative is in general an advantage, for it is thus possible to obtain any desired number of prints from a single exposure in the camera, which is not the case with processes like the daguerreotype, yielding but a single positive for each exposure. Printing is usually effected by placing the negative in contact with a sensitive surface in a printing-frame, and exposing the whole to white light for the necessary time. If all the salts used in printing were affected by light according to the same law, a given negative would give equally good prints, no matter what printing surface were used; but since this is not the case, the result is, as every one quickly learns by trial, that negatives of different gradations are required for the best results with different processes.

The principles on which the various printing processes depend are substantially those already discussed; but as the utmost sensitiveness is not necessary, a larger number of sub-

stances becomes available and a wider range of physical or chemical properties may be employed. Four methods of printing are discussed in this chapter, differing radically from each other in principle. They show the wide range of possibilities in various directions, and each may be taken as the representative of an entire class.

Blue Prints.—The reducing action of light is the basis of a number of printing processes, of which the blue print may be taken as illustrating the case where the final image is formed directly from the reduction-product. In such cases the density of the image is clearly dependent upon the amount of reduction-product present, and can as a rule be only slightly modified by variations in the development.

The preparation of paper for the blue process and its manipulation are so simple and inexpensive that only the rather unsatisfactory color of the image keeps it out of many classes of work, though there is no very satisfactory standard of judgment in this. Just why, for example, a blue portrait should be considered less artistic than a green one is perhaps not quite clear to the skeptic, but such is the fact; and until it is otherwise, the blue print will have to content itself with the industrial field.

In sensitizing paper for blue prints, the following solutions are needed:

Solution A.

Water,	50 parts.
Citrate of iron and ammonium,	10 parts.

Solution B.

Water,	50 parts.
Potassium ferricyanide,	8 parts.

After filtering the solutions separately, they should be mixed in the dark room or in feeble white light and used for coating the paper at once. After allowing enough to fill the brush, each ounce of the mixture will coat ten or twelve square feet of paper.

The paper may be any smooth-surfaced paper upon which a pen could be used with satisfaction, though of course the papers especially prepared for the purpose are best. Small sheets are undesirable; if small pieces of the sensitized paper are wanted, a large sheet should be coated and cut up after drying. The sensitizing operation is easily performed by laying the sheet on a level surface and brushing the mixed solutions over the surface with a wide, flat brush, going over the surface lengthwise and then crosswise as rapidly as possible, so that the sheet may be evenly coated before the solution has time to sink into the paper. The more completely it is kept upon the surface, the more brilliant will be the resulting image.

The paper should then be hung up by the edge in the dark, and drying is a matter of half an hour or less, if the solutions have not been too generously applied. The unexposed sheet is bright yellow, the shadows of the picture changing to a dirty brown color in the printing-frame. The paper thus prepared will keep a day or two before using, but is best used at once; if it is desired to preserve it for longer time, a few drops of a 10 per cent solution of potassium bromide should be added to each ounce of the mixed solutions. Too much bromide, however, will reduce the sensitiveness of the paper considerably.

The action of light is to reduce the ferric salt to the ferrous condition, and the ferrous salt, in combination with the iron,

forms insoluble Prussian blue when the paper is wetted, the unaltered salts dissolving out and leaving the paper white in the unexposed regions as before. Development is therefore reduced to the limit of simplicity; all that is needed is a supply of cold water. It is worth knowing that the whites of the picture can be cleared considerably by carrying the print in the washing tray into bright sunshine after most of the soluble salts have been washed out.

When the water runs clear from the print, it is ready to be hung up and dried. A solution of potassium oxalate applied to the dry print will destroy the blue, and a 20 per cent solution forms a useful ink for writing upon engineering or architectural prints, the writing showing white upon the blue ground.

Blue Line Prints. — A variation of the blue process which gives a color distribution the reverse of the ordinary process is occasionally convenient. It is useful in copying drawings, where blue lines on a white ground are preferred to the white lines and blue ground of the ordinary process. The following are necessary:

Solution A.

Water,	20 parts.
Gum arabic,	4 parts.

Solution B.

Water,	8 parts.
Citrate of iron and ammonium,	4 parts.

Solution C.

Water,	5 parts.
Ferric chloride,	2½ parts.

The gum should be powdered and dissolved cold, and after it is completely dissolved the three solutions should be mixed and thoroughly shaken together. Coating the paper is done

as for ordinary blue prints, but both coating and drying must be as rapid as possible, as the whites of the picture will not be clear unless the solution is prevented from sinking into the paper.

Exposure is as usual, but development is less simple, because the developer will stain if allowed upon the back of the sheet. The best method of developing these prints is to lay the print upon a sheet of glass and brush over it a 20 per cent solution of potassium ferrocyanide. If the whites do not clear, the exposure has been insufficient. After development, the prints should be washed with a stream of water, immersed for a few minutes in a 10 per cent solution of hydrochloric acid, then washed well and dried.

Silver Prints. — Very early in the history of photography pictures were produced by making use of the fact that organic substances treated with silver nitrate darken on exposure to light. Paper coated with silver chloride was also used; but owing to the lack of a fixing agent these pictures could not be made permanent, fading and disappearing on exposure to light. The discovery of the fixing power of "hypo" was all that was needed to revive these processes and to pave the way for the invention of others.

In making prints on paper the fiber of the paper itself interferes seriously with fine definition, and where minute details are to be preserved, it is necessary to form the image in some structureless medium, the paper serving as a support for the delicate film, acting in this respect like the glass of an ordinary dry plate. It also serves as a reflector of the light that passes through the image, thus greatly intensifying the contrasts. The medium used to hold the sensitive substance may be albumen, collodion, gelatine, casein, or some

similar material, or it may itself be sensitized. Sometimes the medium takes part in the light-action, sometimes its function is purely mechanical.

The market is filled with papers of this class, and complete instructions for use accompany each package. The printing in the frame is carried in different kinds all the way from an invisible impression requiring development like a dry plate, up to visible darkening and even obliteration of the details in the shadows. The chemistry of the developing papers does not differ greatly from that already described; in the brands in which an image is visibly formed the reactions are much involved, and only partly determined. In the latter kinds the sensitizing solution is usually silver nitrate, which is generally assumed to form an organic silver compound with the material of the film, and this compound blackens and changes composition in unknown ways by exposure to light.

The invisible image requires development and fixing, the visible image requires fixing only; and simple baths would suffice for these processes were it not that such baths by themselves usually give an unpleasing color to the image, and sometimes produce stains, blisters, or markings of various kinds. Hence the effort of the manufacturer is to provide formulæ which may be relied upon to give satisfactory results under as wide a range of conditions as possible, and this is the reason for the complex treatment sometimes recommended.

Toning. — This is a rather elastic term applied to any process which brings an improvement in the color of the image. For example, with silver papers giving a visible image, the fixing bath alone gives a picture of an unattractive brick-red or salmon color; but an alkaline solution of gold chloride,

applied to the print before fixing, will be reduced by the silver of the image, and the gold will be deposited upon it, changing its color to a pleasing bluish black. Platinum salts will act in the same way. It is of course to be expected that the color of the image will be changed by other reagents, sulphides for example, which change its composition; but such changes as a rule decrease the stability of the final compound forming the image and ultimately lead to its destruction.

Platinum Prints. — The platinum process is an illustration of the case where the reduction-product may be able to reduce to the metallic state a solution that is unaffected by the unaltered salt. Paper coated with ferric oxalate is exposed under the negative, and the light reduces the ferric to ferrous oxalate, according to the following equation:

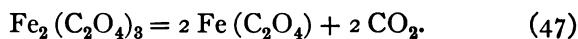

The ferrous oxalate thus formed is soluble in potassium oxalate, and in solution is capable of reducing certain platinum salts to the metallic state. Potassium chloroplatinite is the one usually chosen. It may be coated upon the paper with the ferric oxalate, or supplied in the developer, or all three salts may be put upon the paper in the beginning, the developer then consisting simply of a water bath. At the moment of solution the ferrous salt reacts with the potassium salt as follows:

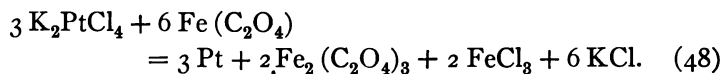

Thus the ferrous image is replaced by one of metallic platinum, in the form of very fine particles. The ferric salts are

dissolved out by immersing the paper for a few minutes in dilute hydrochloric acid, and the print must be then washed and dried. The image is of a beautiful velvety black color, and absolutely unaffected by any reagent which will not destroy the paper.

In the above three methods of printing, it is to be noted that, though the various operations are superficially similar, there is a great difference in the nature of the processes employed. In the printing-out processes, the image is composed of an organic silver compound, which is loaded with gold or other metal by the toning bath, solely for the purpose of improving its color. In the blue process, the reduction-product has its composition changed by the developer, and the density of the image is controlled by the amount of reduction-product formed. In the platinum process the reduction-product serves merely as the agent by which another salt is reduced, the platinum salt taking no part in the first reaction and the ferrous salt being absent entirely from the final image. In developing papers, the image is built up as in the dry plate, though usually with much greater rapidity.

The Carbon Process. — On an entirely different principle, but rivaling the platinum process in beauty of results and having the advantage over it of permitting a selection of color, the so-called carbon process has been brought to a point of reliability and simplicity that makes it a formidable rival of other methods where the finest results are desired. It depends on the long-known fact that gelatine or gum arabic which has been impregnated with potassium bichromate or certain other salts and then exposed to light becomes insoluble in water. If paper so coated is exposed under a negative, the unilluminated portions can be washed away, leaving the image

in the form of a film of insoluble gelatine. Since clear gelatine would give no color contrast with its background, some inert and finely ground pigment must be mixed with it before the paper is coated. The pigment may be of any color or composition, provided only that it is inert, for it takes no part in the photographic process. Curiously enough, finely powdered carbon, which it seems most natural to use and from which the process takes its name, is less satisfactory than pigments of other colors; and when a black image is desired, it is better to use the platinum process.

The manipulation of the carbon tissue would be extremely simple if no half-tones or partial shadows had to be rendered. Under the half-tones of the negative only a part of the gelatine becomes insoluble, the insolubility beginning at the surface facing the light and extending progressively inward as the exposure is increased. Thus the effect of a short exposure is to produce an insoluble layer on top of a soluble one, as illustrated in Fig. 73, where the shaded areas of different

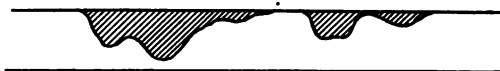

FIG. 73. Formation of Insoluble Gelatine Image.

depths represent light-impressions of varying degrees of intensity. Any attempt at washing, therefore, will be without result until the water can get access to the soluble layer underneath, when the upper layer will be loosened and in most places floated away entirely, damaging or perhaps completely destroying the image. To obviate this, it is necessary to wash the image from behind, and this requires stripping it from its backing and attaching it to some temporary support, upon which the washing can be done without danger of destroying

the delicate film. A second transfer then becomes necessary to the final support, which may be paper or other suitable material.

For some reason or other, the technique of the carbon process has received an undeserved reputation for difficulty and expense. As a matter of fact, it may be questioned whether any other photographic printing process permits such wide variation of treatment for equal goodness of result. Possibly the reason may be found in the fact that the tissue requires preparation by the user in advance, a few accessories are needed which other printing processes do not require, and absolute cleanliness in materials and water is essential.

For details, the reader should study any of the manuals on the subject, but the following is an outline of the manipulations:

The unsensitized, pigmented gelatine is obtainable from dealers in a great variety of colors, in rolls containing about twenty-five square feet each. It has a thick paper backing, and when thoroughly dry is very liable to crack unless carefully handled. Cut sheets are obtainable, but are proportionately much more expensive than the roll tissue. Unsensitized, the material keeps indefinitely.

For the ordinary negative, the sensitizing is accomplished by immersing the paper, cut a little larger than the desired size, for three minutes in a 3 per cent solution of potassium bichromate, to which has been added about 1 per cent of strong ammonia. The chief purpose of the ammonia is to facilitate stripping, as with a neutral or acid bath the backing is sometimes difficult to remove from the film. The hands should be protected by rubber gloves during the sensitizing, as the potassium salt sometimes attacks the skin and causes

sores. After sensitizing the paper must be hung up by the edge and allowed to dry in darkness. This requires some hours, and is best planned to take place overnight.

Exposure in the printing-frame is made as usual, but as the paper is very sensitive and the image invisible before development, some form of actinometer is very desirable. These instruments are in principle somewhat like the exposure

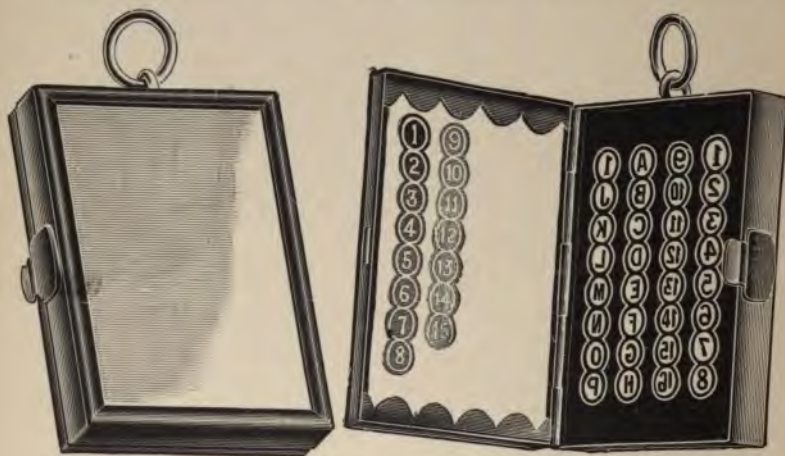

FIG. 74. Wynne Print Meter. Infallible Exposure Meter Company.

meters described on page 133. In the form shown in Fig. 74 the progressive darkening of a strip of sensitive paper gives a measure of the effect of the light. It is in effect a little printing-frame holding a photographic negative consisting of a series of numbers, each separately illuminated by the light passing through a hole in an opaque plate. Diffusion of the light is obtained by the help of a sheet of opal glass in front of the holes, and the holes themselves are graduated in size so that each transmits about 25 per cent more light than the

one next below it on the scale. When a piece of ordinary printing-out paper is placed behind the numbers, the frame closed and exposed to light by the side of the regular negative to be printed, the numbers darken and become visible in succession as the exposure is increased, thus giving a true measure of the photographic effect of the light on the negative. A thin negative needs printing until a low number becomes visible on the paper, a denser one until a higher number shows itself, and so on. A few trials are needed at first to show what indication of the sensitive paper corresponds to correct exposure; but after a little experience the indication of the paper corresponding to a given negative can be judged with almost unflinching accuracy, negatives can be sorted into grades of density by the eye, and mistakes need be very few. The actinometer is also of value for papers like platinum, where the image is only faintly visible, and a small change in color may correspond to a great difference in exposure.

The subsequent manipulation of the paper differs slightly, according as the "single" or "double" transfer process is used. The washing must be done from the back of the image, and the transfer necessary for this purpose reverses the image from right to left. If the printing has been done from an ordinary glass negative, a second transfer to a final support is necessary to re-reverse the picture and set it right again. If the printing is done from a reversed negative, or from a film placed face outwards in the printing frame, the print will be itself reversed, and the transfer to the first support is the only one necessary. The first process is called *double transfer*, the second *single transfer*.

Double Transfer Process. — The materials needed for the double-transfer process, which is the one usually employed,

are a sheet of "temporary support," three trays, one of which will bear heat, a plentiful supply of hot water, a sheet of glass or zinc somewhat larger than the paper sheets, a squeegee and some blotters as large as the prints. Trays of sheet zinc are inexpensive and entirely satisfactory. Also there must be provided the necessary quantity of "final support," which is simply paper suitably coated to cause the gelatine image to adhere to it firmly when dry. After exposure the print is well wetted in a tray of cold water and then laid upon the temporary support, which is merely a heavy paper with a coating consisting chiefly of shellac. To insure contact, the print and support should be squeegeed together on the metal plate and allowed to remain under blotters with light pressure for some minutes.

Development consists in immersing the plate in a tray of warm water, until the color begins to ooze out from the edges of the paper. The backing can then be stripped off, leaving the gelatine exposed to the action of the washing water, but with the insoluble portion next to the temporary support and adhering to it. A gentle stream of water, whose temperature should be varied to suit the effect desired and the exposure the print has received, will gradually wash away the soluble gelatine, leaving the image in a beautiful relief upon its background. Development is stopped by immersion in cold water, after which a five-minute soaking in a 5 per cent solution of alum is required to harden the gelatine. A rinsing after the alum bath is followed by laying the final support down upon the print, squeegeeing them together, and hanging up to dry. When dry, the temporary support can be peeled off, leaving the print upon its final backing.

Single Transfer.—If the reversal of the image is of no consequence, or if the print is made from a reversed negative or the wrong side of a celluloid film, the print can be mounted at once upon its final support, and the second transfer becomes unnecessary. This process saves a little labor, but the saving does not warrant making a reversed negative for the purpose, except for a large number of prints.

CHAPTER XVI.

LANTERN SLIDES.

THAT the lantern slide occupies a wide and constantly increasing field is not open to question. The lantern has long been indispensable to the lecturer upon travel or exploration. It is a fixture in the hall of the scientific society, and the lecture room of the college; it is taking possession of the lyceum and has even invaded the Sunday school. Whether for entertainment or study, the work of the sculptor and the architect can be brought before an assembly in no other practicable way; the discoveries of the archæologist take on new life and beauty through this truly magic apparatus, and even the masterpieces of the painter may sometimes be treated not unworthily in monochrome. The technical worker finds it a valuable aid in presenting his paper before his professional association, and many a fascinating story of scientific and industrial achievement is told upon the screen by speakers too modest to speak of themselves.

A lantern slide is simply a print upon glass instead of paper. It is made upon a photographic plate which is treated as other plates are treated, with only slight modifications of detail.

The first limitation is that of size. English lantern plates are $3\frac{1}{4}$ inches square, while the standard American size is $3\frac{1}{4} \times 4$ inches. The latter size is naturally a trifle more expensive than the smaller plate, but has the advantage of giving more space at the sides of the picture for title and other memoranda. The size of the picture itself should not exceed $2\frac{1}{2}$

inches square. Though an occasional lantern will fill an opening a little larger, it is not wise to assume that all lanterns are as generously built. This limit of size divides lantern slides into two classes: slides made by contact printing, and those made by copying, usually by reduction from larger negatives. Slides made by contact are the simplest to manipulate, and are here discussed first.

Lantern Slides by Contact. — The lantern plate is of very thin glass, to prevent cracking in the lantern, and rather sparingly coated with a special, slow emulsion that is comparatively rich in silver and of very fine grain. The fineness of grain can be seen in Fig. 60, page 127. But though slow by comparison with other emulsions, it is still much too rapid for satisfactory printing by daylight, and an artificial light is necessary, all manipulations being of course carried out in the dark room as for other plates. An incandescent lamp of the usual size is by far the best for contact printing, as the light can be turned on or off quickly and easily. If this is not available, the next best thing is a gas-jet fitted with electric spark ignition. A less satisfactory method is to inclose the source of light in a box with a light-tight door, or to keep it out of the room altogether, opening a slide to admit the beam as desired. The negative from which the slide is to be made should be of the sharpest possible definition, and must have every detail visible, but should not show much contrast. The tendency of the lantern-slide process is to increase contrast, and a negative showing great contrast at the start will not give a good slide, except of course in the case of a line drawing or similar subject. The ammonium-persulphate reducer is a valuable aid in the treatment of over-contrasted negatives.

Whatever the size of the negative, it is necessary to center

the picture properly upon the slide. This can readily be done by putting the negative and lantern plate into a printing-frame, holding the frame up before the dark-room light, and looking through the back of the translucent lantern plate, moving it over the negative until it is in the desired position. It is advisable to lay a piece of black velvet or other soft non-reflecting material against the back of the lantern plate before closing the frame. The white light is then turned up for the desired number of seconds and then extinguished. With a 32-candle-power incandescent lamp, at a distance of four feet from the negative, the exposure will range from three to forty seconds, according to the density of the negative and the results desired. The print can often be greatly improved by shading parts of the negative with the hand or a bit of dark paper during exposure, keeping the shadow moving to avoid marks showing at its edges.

The plate is now ready for development. Since it is not merely a means to an end, but an end in itself, it is necessary to treat it a little more carefully than if it were an ordinary negative. In the first place, it is absolutely essential to use a developer that will not stain. If clear, the hydroquinone developer of page 135 may be used, or the developer recommended by the plate maker, which is usually a metol developer of some kind. For line drawings, or wherever intense contrasts are desired, the author finds the hydroquinone-eikonogen developer unsurpassed; but where delicate gradations are to be preserved, it is inferior to the ferrous oxalate developer of page 136. This gives an image of exquisite gradation; its disadvantage is that it oxidizes so rapidly that it can be used to develop only one or two traysfuls of plates, after which it must be thrown away.

It is a good rule that the highest light of the picture should be clear glass. Therefore, development must not be carried beyond the point where the slightest veil of fog appears, unless reduction is intended after fixing. The unexposed edge of the plate is a good guide on this point, and the emulsion is so slow that the plates may be examined freely in quite a strong light during development. Development is much quicker than for ordinary plates, and the thinness of the film makes it an easy matter to judge of the density of the image by transmitted light. The image shows distinctly on the back of the plate, but this is no guide to its density; transmitted light must be used. The development of the ordinary negative is an interesting process, but is far less so than watching the growth of the delicate positive image on the lantern-slide plate, and the appearance of its details one after another. As a rule, development should be carried very little beyond the point where the image shows with full distinctness against its white background; and as it is a positive, the lights and shadows can be judged without difficulty. Even the slightest veiling of the image cannot be permitted, as it mars the result on the screen.

After a rinsing under the faucet the plate may be fixed in the bisulphite fixing bath already described. A plain hypo bath cannot be recommended on account of its liability to produce a slight yellowing unless perfectly fresh. The plates fix rapidly, and the image loses less in density than in ordinary plates, though different brands differ somewhat in this respect.

After fixing, an examination of the plate in white light will often show that the picture can be improved by the judicious application of the Farmer or the persulphate reducer.

Only experience can give the knowledge needed to determine how dense the image should be, and indeed the density should be different for different lantern illuminants, a picture presenting a fine appearance upon the screen with electric light sometimes appearing altogether too dense and muddy with a lamp of less power. Intensification should never be employed. Apart from the questions of stain and deterioration, the blocking up of the lines and shadows produces a muddiness that overbalances any possible gain from increased contrast.

In the case of a line drawing, it is safe to say that an application of the Farmer reducer is always advantageous. Even heavy fog can be removed without damage to the lines unless they are very fine, and in many cases it is best to

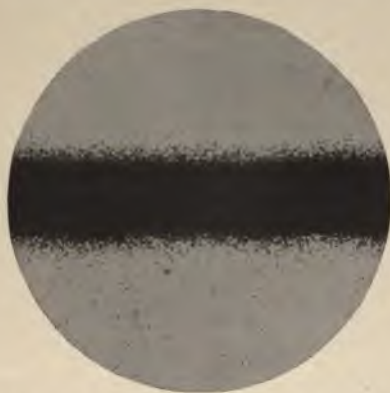

FIG. 75. Photomicrograph $\times 200$. Part of a Lantern Slide before Reduction.

carry the development to the point of appearance of fog, and then to remove the fog afterwards. This operation often serves to bring out fine lines and good contrasts otherwise unobtainable. Even when the plate appears perfectly clear, a line drawing can be improved by the momentary application of the Farmer reducer, as can be seen

from Figs. 75 and 76. Figure 75 shows the appearance of a fine line, about $\frac{1}{500}$ inch in width, upon a good, clear lantern slide, magnified 200 diameters. Grains of silver can

be seen in the clear field, and the edges of the line are distinctly ragged. Figure 76 shows the same line after a short immersion in the Farmer solution. The specks have nearly all disappeared from the background, and the edge of the line is decidedly improved. The difference between the lines of Fig. 75 and Fig. 76 would scarcely be perceived on the screen directly, for the magnification of the illustrations is much greater than that obtainable by a projection lantern; but it would be noticed that the cleared slide appeared rather brighter and sharper than the un-cleared one. It would have been quite possible to increase the difference between the two pictures by taking an extreme case, but their purpose is merely to show that even a good result can be made better.

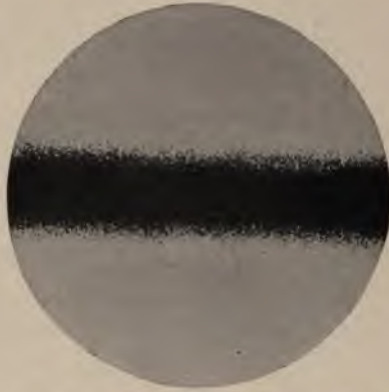

FIG. 76. Photomicrograph $\times 200$. Part of a Lantern Slide after Reduction.

After a five-minute washing, the lantern slide should next be transferred to the following clearing and hardening bath:

Water, 60 parts.
Alum, 2 parts.
Citric acid, 1 part.

It should remain in it five or six minutes, after which the final washing remains to be given. This bath serves in part to remove any traces of stain from the film, but chiefly to

harden the gelatine so that it will be less hygroscopic after drying, and thus less likely to melt when subjected to the heat of the lantern. The bath should be used for only one batch of plates, and then thrown away.

Mounting. — Since the finished slide is used under conditions which make careful handling impossible, it is necessary to protect the film by a cover-glass, binding the two plates together with a strip of gummed paper. Between plate and cover glass a *mat* is placed, which is merely an opaque paper border masking everything outside the chosen area of the picture. Mats are obtainable in a great variety of shapes and sizes, but it may be questioned whether any form is as satisfactory as a plain square or nearly square rectangle of full size. Circles, ovals, and irregular shapes are occasionally useful; but as they are apt to distract attention from the picture, which is the real purpose of the slide, they are not to be recommended.

Use of Spoiled Plates. — Despite the great latitude of the lantern plate — which means that it is very easy to produce passable slides — there is nevertheless one exposure for the lantern plate under a given negative that will give better results than any other, since it is necessary to give heed to the actual as well as the relative densities of the image. It is well worth while for the careful worker to experiment freely to find this exposure, after the manipulations have been once learned. The advice is given without hesitation, for experiments on lantern plates are not only interesting, but inexpensive, because spoiled plates can be converted into cover glasses that are better than those usually obtainable from dealers, and half the cost of the original plate can be recovered in this way.

The conversion of a spoiled plate into a cover glass is a simple process, without resorting to the task of scraping off the film with the finger-nail. An unfixed plate may be allowed to dry without washing, when the film can be easily stripped off, sometimes detaching itself spontaneously. Plates that have been fixed and washed will not part with their films as readily. Some brands can be cleaned simply by hot water; but the author prefers to soak them in a 20 per cent solution of hydrochloric acid, laying a loop of cotton string between adjacent plates to give the acid free access to the gelatine. After a few hours in this bath the plates can be removed to a tray of clean water and scrubbed one by one under the faucet with a small stiff brush, and then set in the plate rack to dry. This treatment leaves them beautifully clean.

The Copying Camera. — When the picture is too large (or, rarely, too small) for direct printing, it is necessary to use a copying camera or its equivalent, in order to obtain an image of the desired size on the plate. Copying is merely photographing a picture or negative at close range.

The construction of the copying camera is outlined in Fig. 77. *ABC* is a long, double-bellows camera intended to rest upon a table, and carrying the negative to be photographed at the end *A*. The lens is mounted on a board *B*, and the ground glass is placed at *C*. The negative is held in a reversible holder that can be moved up and down and sidewise, a number of kits being provided to hold different sizes of plate. It is an advantage to have the holder also capable of turning, like the revolving back of an ordinary camera; for the extra weight is of no consequence, and it is often the case that horizontal and vertical lines are not parallel to the sides of the

negative, necessitating turning the plate relatively to the negative. In the printing-frame this is of course easily managed, but in the copying camera only a little turning motion is possible unless a revolving back is fitted. To obtain various ratios of size of object and image with a given lens, the board *B* and the ground glass *C* are made to slide along the camera bed, and can be clamped at any point. Cameras are obtainable, designed to copy from one fixed size to another, and lacking the extension feature between *A* and *B*. They are low-priced, but their usefulness is of course limited.

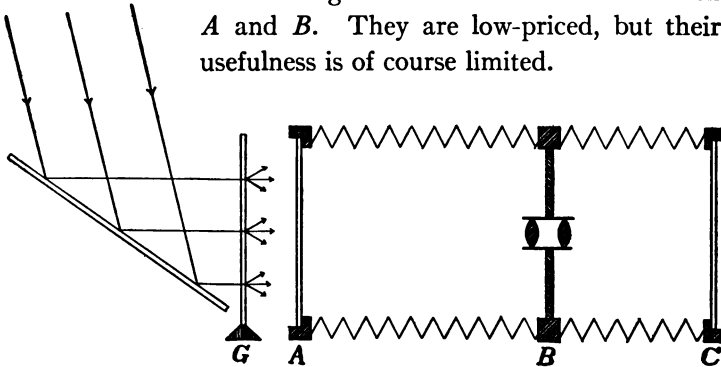

FIG. 77. Copying Camera.

For lantern-slide work it is wise to have a mat of the desired size ready prepared, which can be laid against the ground glass and the size of the image adjusted by moving *B* and then *C* until the result is satisfactory. It is often necessary, however, especially in industrial photography, to have the image a definite fraction of the size of the object. The process of trial and error is unnecessarily tedious, and can be avoided entirely by applying the principles laid down on page 14. It follows from the analysis there given that if the object is n focal lengths in front of the front focal

point of the lens, the image will be exactly $\frac{1}{n}$ of the size of the object. The method of applying this is as follows:

Having located the front focal point as described on page 16, and measured the focal length of the lens, preferably by the same method, set the lens board so that the front focal point

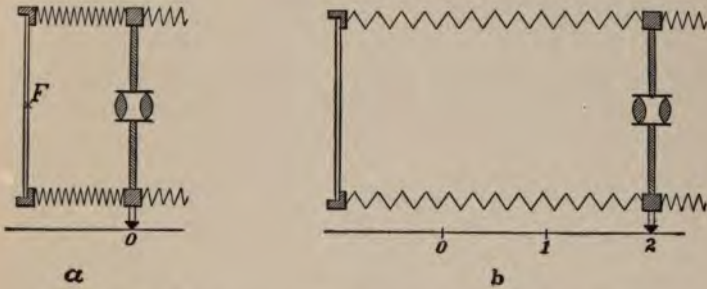

FIG. 78. Enlargement and Reduction in Given Ratios.

F lies in the plane of the negative, as shown in Fig. 78 *a*, and mark the position of the lens board on the camera bed. This is the starting or zero position, and should be marked 0. Successive focal lengths should then be laid off from this point along the camera bed, and numbered 1, 2, 3, etc., as shown in Fig. 78 *b*. It is then easy to see that when the lens board is at the mark 2, for example, the object lies two focal lengths away from the front focal point, and that consequently the image will be half-size. That is, to obtain a half-size (linear) image of any negative, set the lens-board at mark 2, and when the image is focused, by moving the ground glass only, it will be of the required size. Other ratios are obtainable in the same way. In fitting a lens to a particular camera, equation (6), page 14, also shows the limits of the size-ratio *n* obtainable, for if the maximum extension of the

bellows be put equal to $(n + 1) f$, n can be found for any given value of f , the focal length of the lens.

Illumination. — Lighting the negative, unless it is a small one, is a rather troublesome matter. It is necessary to put a sheet of ground glass (G in Fig. 77) between the source of light and the negative, to avoid streaks of light and shadow; and if placed very near the negative, its own grain will show upon the image. Direct sunlight, even if it were always available when wanted, is too variable to be of much service; and the light of the sky or an artificial illuminant is preferable, though of course much slower. Sky light can be reflected upon the ground glass by a mirror M set at the proper angle; the light from the unclouded north sky is quite uniform.

Artificial lighting is more difficult to manage. A single source, like an arc light, will give a direct illumination that falls off rapidly toward the margins of the negative, unless it is a small one. In order to obtain uniform illumination, the lamp must be placed in front of a collecting (convex) lens at such a distance that the beam would come to a focus at the diaphragm of the photographic lens if the negative were removed. This is the only satisfactory way of dealing with the illumination from a single source; and in critical photography with the microscope a similar procedure is essential. The collecting lens is termed the *condenser*, and must of course be large enough to cover the whole negative with its beam. But a condenser of sufficient size to fill a large negative is expensive, and the arc light not always available, so that the amateur is often driven to a substitute. A bank of incandescent lamps set closely together in front of a board painted white gives a sufficiently uniform illumination when used with a

sheet of ground glass, though it is rather slow. A similar bank of Welsbach gas burners, set in two or three rows, will give equally good results, though they cannot be set one above another, and there is considerable heat produced.

Exposure. — Nothing but experience can give the necessary knowledge on this point, because of the great variation in printing density of negatives. But with a steady source of light the knowledge is quickly acquired, and a batch of negatives can be sorted out by eye into three or four grades of density. The lantern plate has a wide latitude, and good results are obtainable with but little trouble.

Lantern Slides from Drawings and Engravings. — When a lantern slide is to be made from a drawing, or an engraving copied from a printed book, it is only necessary to photograph the drawing as in the case of any other object. It is usually satisfactory to make the negative the size of the finished slide, so that the printing can be done directly, a process which is rather more expeditious and less troublesome than copying in the camera. A line drawing should be photographed on a fine-grained plate which gives intense contrasts, in order to have the lines show black upon a perfectly clear background. Such plates are obtainable under the name "contrast" plates, or a lantern plate can be used equally well. In skillful hands ordinary slow plates will answer, but they are not nearly as good, as may be seen by comparing Figs. 58 and 59, pages 126 and 127. In copying an engraving from a printed book the surrounding printed matter will show upon the negative. It should be blocked out with black paper or a water-color opaque which is sold for the purpose. Unless the negative is unusually dense, the line of opaque will show through it; but this is of no consequence, for it will either be altogether

invisible on the developed slide or of so slight density that it can readily be removed with a brush dipped in the Farmer reducing solution.

It would seem that slides made in the camera should possess sharper definition than those made by contact printing, but as matter of fact the difference is hardly noticeable. If the original negatives were always of critical definition; if the projecting lenses commonly used gave as good definition as a high-grade photographic lens; and if the lantern slide and the screen were always adjusted parallel to each other and perpendicular to the axis of the lens, it might be worth while to question the definition of the contact-printed slide; but without the fulfillment of all these conditions it is unnecessary to take especial precautions in direct printing beyond the exercise of care that the plate and negative are in close contact in the printing frame, and that the frame faces the light squarely, as judged by the eye, and not nearer than about four feet. Slides of such drawings as are used for the illustrations of printed books are most readily made by contact printing, as it is very easy to get the image of the right size at once. In making a drawing to be photographed, it is best when practicable to keep it within the limits of about a foot square; a paper without glaze should be used, and India ink is essential to good results. The width of the lines, within the above limit of size, need not then be a matter of much concern to the draughtsman. Given full development and proper clearing, if necessary, lines not more than the five-hundredth part of an inch in width upon the finished slide will show clearly and sharply on the screen. The lines of Figs. 75 and 76 are of this width on the original plate. With a good lens, well stopped down, it is possible to show without much

difficulty lines less than half as wide, but the deposit is then so attenuated that the ferricyanide clearing solution cannot be used without destroying the line altogether.

Enlargements. — In addition to lantern-slide work the copying camera is available for making enlarged or reduced negatives, transparencies, and prints upon bromide paper. When made for large plates it is a bulky and rather expensive piece of apparatus, but if much work of the kind is to be done nothing is quite as satisfactory, unless an entire room can be fitted up especially for the purpose. For temporary use it is entirely practicable to use an ordinary camera, if large enough, in the following way:

Place the negative to be copied against a window pane, facing the sky or lighted from the sky by a mirror placed at the proper angle, and exclude all other light from the room except that coming through the negative; then photograph the negative in the usual way. This of course converts the whole room into the *AB* portion of the copying camera. It is quite necessary to exclude all stray light as described, to avoid veiling of the image by reflection from the inside of the camera bellows, and the same precaution should be taken if the copying camera is used. If the negative does not fill the opening of the kit, the clear spaces must be covered with opaque paper.

In making enlargements, a good lens is necessary, and it must in general be well stopped down to give as sharp an image as possible. A negative which has good definition may usually be enlarged as much as three diameters without undue loss of definition. Concerning the advantages of enlargements in general, it may be said that a camera, not usually larger than 4×5 , is a part of every tourist's outfit, and it is a

question whether more pleasure would not be obtained by a small number of enlargements from selected negatives of the tour than from a small-sized and unsatisfactory print from every one, good and bad.

To make an enlarged negative requires making an intermediate positive from which the second negative is made in turn. It is of course possible to make the increase of size at either stage, or to divide it between them; for example, in enlarging from 4×5 to 8×10 the positive might be made on a plate either 4×5 , 5×7 , $6\frac{1}{2} \times 8\frac{1}{2}$ or 8×10 . It economizes material to make the positive no larger than the original negative, and this would be the only course to take were it not that almost every negative requires more or less retouching, and to do this in such a way that it will not show when enlarged is beyond the powers of all but the most expert. For the worker of ordinary skill in retouching, it is much better to make the positive the full size of the final picture. Everything then shows, in light and shadow, exactly as it will be upon the finished print, and the retouching operation becomes vastly less difficult. The expense of the larger plate is a decided objection, but it is justified by the results obtained and the saving of labor.

The tourist intending to preserve the record of his travels in this form must fit his camera with a first-class lens. Lenses of inferior quality will not make negatives of sufficiently good definition to bear enlargement.

The Lantern. — Not a little of the deserved popularity of the lantern slide is due to improved projection apparatus. It is now possible to obtain a satisfactory lantern at a reasonable price. An oil lamp with three or four wicks or a properly fitted Welsbach light is bright enough for pictures not over

six or eight feet in diameter. Next in order of brightness come the multiple-burner acetylene lamps and the specially made incandescent electric lamp. The latter is a lamp of large candle-power with a filament coiled into a compact helix, and fitted, like the preceding, with a reflector, the filament occupying the focus of the reflector and the condenser as nearly as possible. The acetylene lamp gives a brilliant white light, but must usually have its own generator attached, which sometimes gives trouble by irregular action; the incandescent lamp can, of course, be used only where an electric supply of the proper voltage is available.

Lime Light. — When pictures ten feet or more in diameter are required, recourse must be had to the lime light or the electric arc. The lime light is produced by directing a jet of burning hydrogen (or more commonly illuminating gas) and oxygen against a cylinder of lime, which is raised to brilliant incandescence by the intense heat. In the hands of a competent operator the lime light is the steadiest of all the brighter artificial illuminants used for lantern purposes; but the necessary gas tanks, the compressed gases themselves, and the accessory apparatus make it rather troublesome and expensive, and there is danger in ignorant or careless handling. Still, professional operators use it almost exclusively, because of its reliability and independence of local conditions. Its supremacy is threatened, however, by the electric arc, which is much to be preferred wherever it is possible to obtain the necessary electric supply.

The Electric Arc. — In addition to the necessity of an electric supply, a further serious limitation upon the use of the arc is its demand for a much heavier current (from 8 to 25 amperes) than can be taken from the ordinary fixture,

which, therefore, necessitates a special distributing circuit from the house mains. Were it not for this, because of its cheapness, cleanliness, and safety, it would hardly have a rival.

Everybody is familiar with the appearance of the arc lamps used in the streets at night, and the lantern arc differs from them only in details. The ordinary open arc has the appearance shown in Fig. 79. The positive carbon burns with a



FIG. 79. Open Arc.

crater-like depression from which about 85 per cent of the light comes, most of the balance coming from the negative carbon and but little from the flame itself. This distribution makes it necessary to arrange the lamp so that the bright crater will throw its light in the desired direction. In street lamps this is easily done by putting the positive carbon

uppermost, but for lantern use a slightly different arrangement is used, to prevent obstruction of the light by the negative carbon. The carbons are offset about half a diameter (a distance of about a quarter of an inch in the usual lantern sizes) and this causes the crater to burn to one side, thus throwing most of the light in one direction.

Several forms of lamp are on the market in which the carbons are set at an angle, sometimes as great as 90° . A side

view of a 90° arc is shown in Fig. 80. By this method the negative carbon is taken practically out of the field of view, and the illumination is very satisfactory.



FIG. 80. 90° Arc.

Condenser. — A condensing lens must be used to throw as much as possible of the light through the slide upon the projecting lens, and for this the arc has another purely optical advantage in that the crater is very small, hardly larger than the end of a lead-pencil unless the current is very heavy. It can therefore be placed very nearly at the geometrical focus of the condenser, and the light can be adjusted upon lens and screen with ease.

Alternating Current Arc. — The direct-current arc leaves little to be desired in many ways; but the same cannot be said of the arc fed by alternating current. The chief trouble is the annoying hum caused by the current itself. It can be diminished by careful design of the lamp, and can be muffled by inclosing the whole apparatus in a box of sufficient size,

but this makes the manipulations difficult. The only satisfactory way out of the difficulty is to put lamp and operator in another room. It will also generally be found that the alternating arc requires considerably more current than the direct-current arc giving the same illumination on the screen.

Projecting Lens. — A suitable condenser is usually supplied with the lantern, leaving the projecting lens as the only part of the optical system to be selected by the purchaser. It should show no distortion, must have a flat field, and be sensibly free from astigmatism. Aside from a test of the quality of the lens, which is practically limited to an examination of its power of definition upon the screen, the item of chief importance is the focal length. The requirements of the projection lens are stated a little differently from those of the photographic lens. Instead of having a definite focal length specified, or a given width of angle, or a certain rapidity, the projection lens is required to give a picture of a certain size at a given distance, or perhaps in a room of given dimensions. Its angle is always very narrow.

The calculation is a simple application of equation (6), page 14. A single illustration will suffice. Suppose, for example, that a lens is required to give a 10-foot picture at a distance of 40 feet from itself. Though the actual opening in the lantern-slide rarely exceeds $2\frac{7}{8}$ inches either way, it is well in the calculation to allow 3 inches, for an occasional slide that may be improperly mounted or unusually long. In the given example, the enlargement will be 40 diameters. Denoting the focal length of the lens by f , the screen will then be $40f$ from the front focal point of the lens, or $41f$ from the diaphragm, assuming that the nodal points are

coincident, which is very nearly true for the symmetrical projecting lenses commonly used.

Therefore,

$$41 f = 40 \text{ feet} = 480 \text{ inches};$$

$$f = 11.7 \text{ inches.}$$

In the actual case, a lens would be selected whose focal length came nearest to the calculated value; and if an exact size of picture were essential the lantern would be moved accordingly. It is possible to change the focal length of the lens slightly by unscrewing the glasses in the lens barrel; but this is generally at the expense of definition. Sets of three or four single lenses are obtainable, fitting together like the convertible lenses already described; but they are expensive and rarely needed, except for professional use.

Screen. — In passing, a word should be said about the screen on which the image is projected. Though often used, white cotton sheeting is far from being the best material. This can readily be proved by observing the screen from behind while the image is upon it. It will be found that the picture can be seen about equally well from either side, showing that substantially as much light is transmitted as reflected, half of it being lost to the spectator in either case, and the brilliancy of the image suffering accordingly.

The best surface for receiving the lantern picture is a white plastered wall, but as this is rarely available portable screens must be used. These are made of cloth, covered with a suitable sizing, and then painted white or very pale blue. They are very good, but rather expensive, heavy, and not easy to roll up without danger of cracking the surface.

CHAPTER XVII.

SHUTTER EXPOSURES.

EXPOSURES of half a minute or more are most conveniently made by uncapping the lens. The lens cap should fit just tightly enough to retain its hold on the barrel when the lens is turned upside down. The camera is likely to be jarred by removing a tightly fitting cap; and while this would be of no consequence in an exposure lasting five minutes or more, it might be disastrous to an exposure of a few seconds. With care and a properly fitted lens cap exposures down to about one-fifth of a second can be made in this way, but below this limit some form of shutter becomes essential. For convenience, shutters are nearly always fitted with some form of pneumatic release, which has the further advantage of allowing the shutter to be operated from a distance, if necessary.

The term *instantaneous photograph* has found extensive use in describing pictures taken with short exposures. It is of course erroneous, because a finite time, no matter how short it may be, is necessary to impress the image on the plate. There are, however, two distinct classes of photographs, each requiring a very short exposure — though for entirely different reasons — to one of which the term *instantaneous* may perhaps be applied with less inaccuracy. The first class is represented by the well-lighted landscape, which may be photographed with a large stop in $\frac{1}{100}$ of a second or less; anything more than this may mean over-exposure. In the second class lie photographs of objects in motion, where the time of

exposure is limited by the amount of permissible blurring of the image. Such a photograph gives one particular phase of the motion, which is usually too brief to be perceived by the eye, and which therefore may be termed instantaneous.

It is important to note the fundamental difference between the exposure calculations in the two cases. In the first case, the exposure is determined, like any other, by the intensity of the light and the size of the stop; in the second case the exposure is limited by the motion of the object, altogether irrespective of other conditions.

To base an exposure calculation upon the allowable blurring of the image requires, as in the calculation for depth of focus, a definition of the limits of allowable blurring. It is customary to take a displacement of 0.01 inch as the limit; that is, the object must not move far enough during the exposure to cause its image to travel more than 0.01 inch over the plate. This limit is of course quite arbitrary; for small pictures, to be afterwards enlarged, the allowable displacement should be less; while for large pictures, to be viewed directly, the blurring may be greater without harm. Whatever assumption may be made on this point, it is an easy matter to deduce the principle upon which exposure calculations are based, though any attempt to generalize it leads to a formula which is both difficult to remember and impossible to use when one is in a hurry.¹

The deduction of the exposure formula is simple. Figure 81 represents an object at *A* giving an image at *A'*, and when

¹As an illustration, the following rule may be cited, as given in a maker's catalogue: "The distance of the object from the camera, measured in inches, must be divided by the number of yards per hour at which the object is traveling, multiplied by the focus of the lens in inches." This gives the exposure in seconds.

moved to B giving an image at B' . It is plain that the relative displacements of object and image are in the ratio $\frac{p}{p'}$, their respective distances from the lens.

To determine the displacement of the image for an exposure of given length, or, conversely, to find the exposure corresponding to a given limiting displacement, it is therefore necessary to know the velocity of the moving object, its dis-

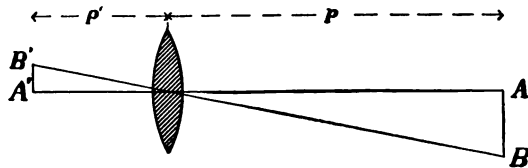

FIG. 81. Relative Displacement of Object and Image.

tance from the lens, and the focal length of the lens itself. The problem may be simplified by taking advantage of the fact that p is always considerably greater than the focal length of the lens f , so that the distance between lens and image is practically equal to f . Also, let

t = time of exposure, in seconds.

v = velocity of moving object, in inches per second.

0.01 = allowable displacement of the image, in inches.

Then, from the similar triangles of Fig. 81,

$$\frac{\text{displacement of object}}{\text{displacement of image}} = \frac{vt}{0.01} = \frac{p}{f}, \quad (49)$$

whence

$$t = \frac{0.01 p}{vf}. \quad (50)$$

Thus, for a given lens, the allowable time of exposure is proportional to the distance of the moving object, and in-

versely proportional to its velocity, and in any case varies inversely as the focal length of the lens.

The working difficulty with this or any other similar formula arises from the lack of uniformity in the common units of time and distance. The distance p is naturally expressed in feet, v is estimated in miles per hour, while f is measured in inches and t is desired in seconds; in equation (50), however, everything must be expressed in inches and seconds, or some other units consistent with each other. If it is desired to obtain t in seconds, having p in feet, v in miles per hour and f in inches, equation (50) becomes

$$t = \frac{.0006818 p}{vf}, \quad (51)$$

which is obviously useless in the field.

But by making the proper substitutions in this equation, tables of allowable exposures for different velocities at given distances may be calculated for any lens. One such table is given for illustration. It is calculated for a lens of 4 inches focal length, but may be converted into a table for any other focal length by multiplying the exposure times by the fraction $\frac{4}{f}$. The tabular numbers are exposures in seconds.

TABLE VI. ALLOWABLE EXPOSURE IN SECONDS, WITH A LENS OF 4" FOCAL LENGTH.

Object-Distance in feet.	Velocity in miles per hour.									
	4	5	6	8	10	15	20	30	40	50
10	0.0043	0.0034	0.0028	0.0021	0.0017	0.0011	0.00085	0.00057	0.00043	0.00034
15	0.0070	0.0051	0.0043	0.0035	0.0026	0.0017	0.0013	0.00085	0.00064	0.00051
20	0.0085	0.0068	0.0057	0.0043	0.0034	0.0023	0.0017	0.0011	0.00085	0.00068
30	0.013	0.010	0.0085	0.0070	0.0051	0.0034	0.0026	0.0017	0.0013	0.0010
40	0.017	0.014	0.011	0.0085	0.0068	0.0045	0.0034	0.0023	0.0017	0.0014
50	0.021	0.017	0.014	0.011	0.0085	0.0056	0.0043	0.0028	0.0021	0.0017
100	0.043	0.034	0.028	0.021	0.017	0.011	0.0085	0.0056	0.0043	0.0034
200	0.085	0.068	0.057	0.043	0.034	0.023	0.017	0.011	0.0085	0.0068

This table does not allow for the movement of limbs, wheel spokes, or other parts of an object which may be moving faster than the average velocity of the whole, and which therefore require a still shorter exposure for sharp definition. On the other hand, if the object is not moving directly across the field, but obliquely, the limiting exposure is greater; and if the motion is directly toward or away from the camera, there is no transverse motion of the image as a whole, and the only cause of blurring is the change in size of the image as the object changes its distance from the lens.

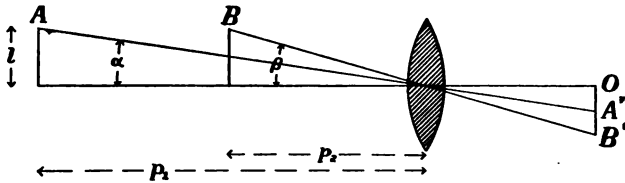

FIG. 82. Motion of Object in the Line of Sight.

When the motion is directly in the line of sight, it can be shown by a simple analysis that the exposure may be considerably lengthened without fear of blurring, though the multiplying factor is not a constant. In Fig. 82, let the object move from A to B , its image enlarging from OA' to OB' . Also, let

p_1 = distance of moving object at beginning of exposure.

p_2 = distance of object at end of exposure.

$A'B'$ = allowable displacement of image outline.

L = half the greatest diameter of the object.

Then

$$\begin{aligned} A'B' &= OB' - OA', \\ &= f \tan \beta - f \tan \alpha, \end{aligned} \quad (52)$$

since the image is practically at the principal focus of the lens. www.libtool.com.cn

Next, from (52),

$$A'B' = f \frac{L}{p_2} - f \frac{L}{p_1} = fL \left(\frac{p_1 - p_2}{p_1 p_2} \right) \quad (53)$$

$$\frac{A'B'}{p_1 - p_2} = \frac{fL}{p_1 p_2} = \frac{fL}{p^2} \text{ approximately,} \quad (54)$$

representing by p the average distance of the object during the exposure. That is,

$$\frac{\text{displacement of image}}{\text{displacement of object}} = \frac{fL}{p^2}. \quad (55)$$

Comparing this with the result of equation (49) for transverse motion:

$$\frac{\text{displacement of image}}{\text{displacement of object}} = \frac{f}{p}, \quad (56)$$

it appears that for direct forward or backward motion the allowable change of position of the object during exposure is greater than for transverse motion in the ratio $\frac{p}{L}$, or its distance divided by half its greatest diameter. This ratio may have any value from about 3 upwards; 6 being perhaps a fair average for street scenes. In other words, an object moving in the line of sight may receive without undue blurring about six times the exposure allowable for transverse motion; and in general, when an object is moving obliquely across the field, the transverse component of the motion is the deciding factor in the exposure calculation.

Shutter Speeds. — The following table is sometimes used in this connection. It is computed for objects at a distance

from the lens equal to 100 times its focal length, and moving across the field of view.

TABLE VII. SHUTTER EXPOSURES.

Man walking slowly, street scenes, cattle grazing,	$\frac{1}{25}$ second.
Boating,	$\frac{1}{30}$ second.
Man walking, children playing,	$\frac{1}{100}$ second.
Trotting horse, bicycle rider,	$\frac{1}{300}$ second.
Athlete running or jumping,	$\frac{1}{400}$ second.
Bicycle or horse race,	$\frac{1}{500}$ second.
Express train, motor car race,	$\frac{1}{1000}$ second.

Inspection of the two foregoing tables shows that the longest allowable exposure is less than 0.01 second unless the object is at a considerable distance from the lens, or is moving very slowly. This time is below the limit for adequate exposures, unless the light is abundant; and the consequence is that most exposures of this character will give under-exposed negatives if made on the above basis. That they do not do so is due chiefly to the fact that the marked speeds of camera shutters are never exactly correct, and are usually grossly in error, particularly at the higher speeds; exposures nominally $\frac{1}{100}$ second and shorter being generally about half the marked values. At high speeds even the most expensive shutters generally give exposures decidedly longer than the stated values, and the cheaper grades almost without exception will not give exposures shorter than about $\frac{1}{300}$ or $\frac{1}{400}$ second, no matter what figures may be engraved on the shutter dial.

Testing Shutter Speeds. — No reliance can be placed on the accuracy of the speed indications as marked; and even were they correct when the shutter is new, they are almost certain to

change with time and use. It is therefore necessary to test every speed when the shutter is new, and occasionally thereafter, if the user desires to work with a proper knowledge of his apparatus. Simple pendulum testers are obtainable, which are sufficiently accurate for most purposes. The typical form consists of a silvered pendulum ball arranged to swing in front of a graduated arc. This is placed in the sunshine, at a convenient distance from the camera, and the shutter snapped while the ball is swinging. The reflection from the moving ball will show as a streak across the negative, extending over several of the graduations of the arc. It is customary to space the graduations so that each interval represents $\frac{1}{100}$ of a second, and it is then an easy matter to obtain the speed of the shutter by counting the number of intervals crossed by the streak.

Another piece of apparatus for the same purpose, but having a wider range, may be made at home by fastening a silvered ball upon the rim of a wheel. An upturned bicycle will supply the wheel, and a silvered glass ball, of the kind used for Christmas decorations, will answer admirably. With the aid of a watch an assistant can turn the wheel by the crank with all necessary steadiness, and a shutter can be given a complete test in a few minutes. With this apparatus it is necessary to measure the angle subtended at the center of the circle by the streak, which can be done accurately enough with a common draughting protractor. Supposing the angle to measure m degrees, and that the wheel (not the crank) is revolving n times per second, the time of exposure x is found from the equation

$$x = \frac{m}{360 n} \text{ seconds.}$$

Figure 83 represents a test with an apparatus of this kind, but using a cardboard disk instead of a wheel with spokes. It should be noticed that the streak does not terminate sharply, but appears to grow narrower at either end. This is due to the diminished amount of light admitted through the



FIG. 83. Test of Shutter Exposure Time.

shutter when only partly open, a circumstance that has important practical consequences, as will be seen below.

Timing Test by Freely Falling Body. — Still another way, and perhaps the most accurate of all the simpler methods for speedy shutters, is to employ a freely falling body as the moving object. For this purpose it is best to use a half-inch

polished steel ball, of the kind used for ball bearings in machinery, allowing it to fall in front of a suitably marked scale on a long strip of paper. At signal an assistant drops the ball from the zero-mark of the scale, and the shutter is snapped as the ball flashes past the graduations. Only a few feet of scale would be necessary, except for the fact that the inertia of the shutter and the personal equation of the operator may make a number of trials necessary before the ball is photographed against the scale, unless a rather long scale is used.

Figure 84, from a negative by Professor R. R. Lawrence, shows a photograph taken in this way. The scale graduations represent hundredths of a second, so that the exposure was 0.0031 second. The short streak lies between the 0.02 and 0.03 second marks.

For the convenience of those desiring to construct their own scales, Table VIII has been computed. It has been computed for sea-level, at the latitude of Boston ($42^{\circ} 21'$), but may be used practically anywhere with all needful accuracy, the difference between two successive exposures of the same shutter often being greater by several per cent than the differences in the earth's gravitational force. Also, no account has been taken of the air friction against the ball; it is of small effect for the short distances given.



FIG. 84. Test of Shutter Exposure Time.

TABLE VIII. DISTANCES TRAVERSED BY A FREELY FALLING BODY, IN SUCCESSIVE HUNDREDTHS OF A SECOND.

TOTAL TIME OF FALL.	TOTAL DISTANCE FALLEN.	DISTANCE FALLEN IN 0.01 SEC.
Start.	0
0.36 sec.	2 ft. 1.011 in.
0.37 sec.	2 ft. 2.420 in.	1.409 in.
0.38 sec.	2 ft. 3.867 in.	1.447 in.
0.39 sec.	2 ft. 5.353 in.	1.486 in.
0.40 sec.	2 ft. 6.878 in.	1.525 in.
0.41 sec.	2 ft. 8.441 in.	1.563 in.
0.42 sec.	2 ft. 10.043 in.	1.602 in.
0.43 sec.	2 ft. 11.683 in.	1.640 in.
0.44 sec.	3 ft. 1.362 in.	1.679 in.
0.45 sec.	3 ft. 3.080 in.	1.718 in.
0.46 sec.	3 ft. 4.836 in.	1.756 in.
0.47 sec.	3 ft. 6.631 in.	1.795 in.
0.48 sec.	3 ft. 8.464 in.	1.833 in.
0.49 sec.	3 ft. 10.336 in.	1.872 in.
0.50 sec.	4 ft. 0.246 in.	1.910 in.
0.51 sec.	4 ft. 2.195 in.	1.949 in.
0.52 sec.	4 ft. 4.183 in.	1.978 in.
0.53 sec.	4 ft. 6.210 in.	2.027 in.
0.54 sec.	4 ft. 8.275 in.	2.065 in.
0.55 sec.	4 ft. 10.378 in.	2.103 in.
0.56 sec.	5 ft. 0.520 in.	2.142 in.
0.57 sec.	5 ft. 2.701 in.	2.181 in.
0.58 sec.	5 ft. 4.920 in.	2.219 in.
0.59 sec.	5 ft. 7.178 in.	2.258 in.
0.60 sec.	5 ft. 9.475 in.	2.297 in.
0.61 sec.	5 ft. 11.810 in.	2.335 in.
0.62 sec.	6 ft. 2.184 in.	2.374 in.
0.63 sec.	6 ft. 4.596 in.	2.413 in.
0.64 sec.	6 ft. 7.047 in.	2.451 in.
0.65 sec.	6 ft. 9.536 in.	2.489 in.
0.66 sec.	7 ft. 0.064 in.	2.528 in.

www.libtool.com.cn TABLE VIII—Continued.

TOTAL TIME OF FALL.	TOTAL DISTANCE FALLEN.	DISTANCE FALLEN IN 0.01 SEC.
0.67 sec.	7 ft. 2.631 in.	2.567 in.
0.68 sec.	7 ft. 5.236 in.	2.605 in.
0.69 sec.	7 ft. 7.880 in.	2.644 in.
0.70 sec.	7 ft. 10.563 in.	2.683 in.
0.71 sec.	8 ft. 1.284 in.	2.721 in.
0.72 sec.	8 ft. 4.044 in.	2.760 in.
0.73 sec.	8 ft. 6.842 in.	2.799 in.
0.74 sec.	8 ft. 9.679 in.	2.837 in.
0.75 sec.	9 ft. 0.554 in.	2.875 in.
0.76 sec.	9 ft. 3.468 in.	2.914 in.
0.77 sec.	9 ft. 6.420 in.	2.952 in.
0.78 sec.	9 ft. 9.412 in.	2.992 in.
0.79 sec.	10 ft. 0.442 in.	3.030 in.
0.80 sec.	10 ft. 3.511 in.	3.069 in.
0.81 sec.	10 ft. 6.618 in.	3.107 in.
0.82 sec.	10 ft. 9.764 in.	3.146 in.
0.83 sec.	11 ft. 0.948 in.	3.184 in.
0.84 sec.	11 ft. 4.171 in.	3.223 in.
0.85 sec.	11 ft. 7.432 in.	3.261 in.
0.86 sec.	11 ft. 10.732 in.	3.300 in.
0.87 sec.	12 ft. 2.071 in.	3.339 in.
0.88 sec.	12 ft. 5.448 in.	3.377 in.
0.89 sec.	12 ft. 8.864 in.	3.416 in.
0.90 sec.	13 ft. 0.318 in.	3.454 in.
0.91 sec.	13 ft. 3.811 in.	3.493 in.
0.92 sec.	13 ft. 7.343 in.	3.532 in.
0.93 sec.	13 ft. 10.913 in.	3.570 in.
0.94 sec.	14 ft. 2.522 in.	3.609 in.
0.95 sec.	14 ft. 6.169 in.	3.647 in.
0.96 sec.	14 ft. 9.855 in.	3.686 in.
0.97 sec.	15 ft. 1.580 in.	3.725 in.
0.98 sec.	15 ft. 5.343 in.	3.763 in.
0.99 sec.	15 ft. 9.145 in.	3.802 in.

www.libtool.com.cn
TABLE VIII—*Concluded.*

TOTAL TIME OF FALL.	TOTAL DISTANCE FALLEN.	DISTANCE FALLEN IN 0.01 SEC.
1.00 sec.	16 ft. 0.985 in.	3.840 in.
1.01 sec.	16 ft. 4.864 in.	3.879 in.
1.02 sec.	16 ft. 8.782 in.	3.918 in.
1.03 sec.	17 ft. 2.738 in.	3.956 in.
1.04 sec.	17 ft. 4.733 in.	3.995 in.
1.05 sec.	17 ft. 8.766 in.	4.033 in.
1.06 sec.	18 ft. 0.838 in.	4.072 in.
1.07 sec.	18 ft. 4.949 in.	4.111 in.
1.08 sec.	18 ft. 9.098 in.	4.149 in.
1.09 sec.	19 ft. 1.286 in.	4.188 in.
1.10 sec.	19 ft. 5.512 in.	4.226 in.
1.11 sec.	19 ft. 9.777 in.	4.265 in.
1.12 sec.	20 ft. 2.081 in.	4.304 in.

For slow speeds the first portion of the table may be used, but for speeds faster than 0.01 second the last portion is preferable, because the hundredth-second marks are more widely separated and the measurement is easier to make accurately. In this case it is usually simplest to drop the ball from an upper window.

Kinds of Shutters. — Shutters may be divided into several classes, according to their position relative to the lens. In one class, which comprises by far the largest number of shutters in use, the exposure is made by opening and closing an aperture within the lens itself. In another class the exposure is given by moving a perforated curtain or slide either directly in front of the lens or behind it. The third class comprises the so-called focal-plane shutters, which are wholly within the camera box and usually placed close to the plate. Each class has certain advantages and disadvantages not possessed by the others.

Focal-plane Shutter.—The focal-plane shutter is practically a miniature window-shade provided with a slit of adjustable width and long enough to cover one dimension (preferably the longer) of the plate. This shade or curtain is drawn over the plate by a spring-actuated roller very similar to the common window-shade roller, the tension of the spring being adjustable at the pleasure of the operator. The length of the exposure is varied by changing either the width of the slit or its speed across the plate, or both.

This form of shutter has several important advantages, and some disadvantages. It is bulky, adding a good-sized fraction of an inch to two sides of even a small camera. The necessity of winding back the curtain before a second exposure can be made, closing the slit meanwhile or performing some similar operation to avoid re-exposing the plate, is a decided handicap when exposures must be made in rapid succession; and the fact that there are practically two speed-changing devices leads to intricacies of manipulation. At slow speeds, when the tension of the spring is relaxed and its pull feeble, the action of the shutter may be very irregular because of heat or dampness affecting the black varnish of the curtain and causing it to stick. Irregularity, however, is a trouble of which no shutter has a monopoly.

There is a minor difficulty, which is of a totally different nature. It arises from the fact that the plate is not exposed as a whole, but as it were in sections, each portion being uncovered successively by the moving slit. This causes a slight distortion of the image in the line of its motion. If the object moves along the ground, the distortion appears as an elongation or shortening if the slit moves horizontally, or as a tipping forward or backward of the upper portion of the image if the

slit moves up or down across the plate. This is hardly noticeable at ordinary speeds; but if a railroad train or motor car is photographed in full flight, the wheels and other parts of the image are sometimes amusingly distorted, as if bent out of shape by some tremendous propelling force or pressure of air.

On the other hand, the focal-plane shutter has three very great advantages. Being entirely separated from the lens, it cannot jar or shake the glasses in their cells; and this is by no means a trifling matter, particularly with cemented lenses. Secondly, it is practically the only form that will give an exposure of 0.001 second or thereabouts, few if any shutters working at the lens being able to get below 0.005 second, unless by the use of powerful springs that are certain to damage the lens sooner or later. Finally, and perhaps most important of all, its efficiency is a maximum. If the slit lies close to the plate, as it should, the light from the entire area of the lens falls upon the plate during exposure, and there is no partial shading or screening of the lens. Thus the amount of light received by the plate during the exposure is a maximum; and it hardly need be said that this is of the utmost importance with very short exposures. The subject of efficiency is discussed more fully in the following pages, and it will be seen that the focal-plane shutter lies in a class by itself, in efficiency as well as construction.

Shutters working at the Lens. — These have the advantage of small bulk and ease of manipulation, and as a rule the decided disadvantage of low efficiency. Curtain shutters are obtainable, working substantially like the focal-plane shutter, and designed for attachment either immediately in front of or behind the lens. They are lighter, smaller, and cheaper than the focal-plane shutters, but are necessarily of lower efficiency.

But the great majority of shutters working at the lens is of the so-called "between-the-lenses" type. In some forms the shutter blades open and close at the diaphragm, but are independent of it; and in other types the leaves of the iris diaphragm are themselves actuated by the shutter mechanism, opening to the desired size automatically when a suitable index is set. Whatever the type employed, in all quick-working shutters a large part of the time of exposure is consumed in opening to full aperture and then in closing again, the time during which the shutter is actually open being a rather small fraction of the whole. The lens thus works with virtually a smaller stop during a considerable portion of the exposure, and there is an appreciable loss of light in consequence.

Efficiency of Shutters. — The efficiency of a shutter may be defined as the ratio $\frac{L}{L'}$ where L is the quantity of light actually admitted during exposure, and L' the quantity which would have been admitted if the shutter had sprung open instantly to full aperture at the beginning of the exposure, remained wide open during the whole exposure, and then closed instantly. Since this condition cannot be realized by any shutter working at the lens, it follows that the fraction $\frac{L}{L'}$ must be less than unity for all such types. It is often very low, even in expensive shutters for which much is claimed.

A detailed study of the general problem of efficiency involves a rather intricate mathematical analysis, based on the form of the shutter blades and certain assumptions of the circumstances of their motion; *i.e.*, whether it is uniform, uniformly accelerated or retarded, intermittent, and the like. The simplest case to analyze, though it has no direct applica-

tion, is that of a square hole in a board, moving uniformly past another hole of the same size. It can be shown that the light admitted through the openings as they pass each other is just one-half of the light that would have been admitted through the full opening in the same time; that is, the efficiency of such a shutter is 50 per cent. A rectangle whose length is twice its breadth, moving uniformly over a square of the same width, has an efficiency of 67 per cent. A shutter made of two circular holes, passing each other in a similar way, will have an efficiency of 42 per cent. Finally, a diaphragm shutter that shows a circular opening expanding uniformly from zero to full diameter and then contracting uniformly to zero again will have an efficiency of only 33 per cent. These values, however, as obtained by analysis, are not altogether trustworthy indications of the performance of shutters of the given types as they are actually constructed, partly because the forms of the shutter aperture during opening and closing are not usually simple geometrical figures, and partly because the motion of the blades is of a more complex character than that assumed in the analysis. To study the matter in detail for a particular shutter it is necessary to have a series of photographs of the shutter aperture itself, taken at regular and very short intervals during the whole exposure. With such a record it is a fairly simple, though rather laborious, task to compare the quantity of light L admitted during the exposure with the theoretical maximum L' , and thus to calculate the efficiency.¹

Figure 85 shows a number of such records, taken with eight shutters of different sizes and patterns. It is easily seen that in every case the shutter was fully open for only a portion of the time, in many cases only a small portion. The method of taking the pictures was to focus the image of the shutter aper-

¹ DERR, *Technology Quarterly*, September, 1902.



FIG. 85. Shutter Apertures during Exposure.

ture on a strip of photographic film wound on a rotating drum, using a separate lens, and interposing, except for the first picture, a rotating disk in the path of the light, pierced with a ring of small holes. Of course whenever a hole came in line with the lens and film a photograph was taken of the shutter

aperture as it appeared at that instant; and by making the holes numerous and the speed of the disk high it was an easy matter to obtain five or more pictures of the shutter aperture during every hundredth of a second. The first picture was taken without the perforated disk, and the width of the band of light shows the diameter of the shutter aperture at the corresponding moment.

A long series of such experiments upon shutters of many different patterns leads the author to the conclusion that shutters working at the lens and having a nominal speed of 0.01 second or thereabouts will rarely have an efficiency higher than about 65 per cent, and some patterns will show less than 50 per cent. At slow speeds, or with smaller stops, the efficiency may rise to 80 per cent, but unfortunately high efficiency is of much less value under these conditions. This means that in ordinary use the operator is getting only half or two-thirds as much light through the lens as the shutter dial may lead him to expect, even after allowing for errors of speed; and if the speeds were correct as marked, the production of under-exposed negatives would be even larger than it is now. To put the case in another way, a lens working at $\frac{f}{5.6}$ and fitted with a shutter of 50 per cent efficiency is no better for short exposures than a lens working at $\frac{f}{8}$ with a focal-plane shutter, although the first combination may cost nearly half again as much as the second. This is in practice a serious matter, and one not fully appreciated by the majority of users. If a tithe of the effort could be put into the design of efficient and reliable shutters that is expended in less important but more showy details, outdoor photography would profit greatly.

CHAPTER XVIII.

COLOR PHOTOGRAPHY.

INSPECTION of the brightly lighted and beautifully colored image of a landscape or similar subject on the ground glass of the camera is naturally followed by the wish that the colors as well as the form might be fixed upon the plate. It is most natural to seek a substance with which the plate may be treated to produce the desired result; but a little thought will show that the prospect of obtaining pictures in natural colors in this way is not a very hopeful one. Such a substance would have to be sensitive to the whole range of the spectrum in proportion to its luminosity, and the necessary treatment after exposure would have to produce such alteration in it as to make it capable of reflecting or transmitting light of the same intensity and color as that which originally affected it. Many attempts have been made in this direction, but only a few of them give promise of even partial results. One of these, the Szczepanik process, is described below. The advances that have been made in color photography have been made by other methods.

Practicable color photography is divided into two classes: direct and indirect processes. Of the former, the process devised by Professor G. Lippmann is the only one that has emerged from the laboratory stage of development; and it requires a considerable skill in manipulation and some unusual accessories in equipment.

Lippmann Process. — The colors of a Lippmann photograph are interference effects, produced by layers of silver in the film. The mode of formation of these layers is as follows:

If a light-wave falls perpendicularly on a reflecting surface, the combination of the direct and the reflected wave will produce a succession of points of maximum and minimum disturbance, as shown

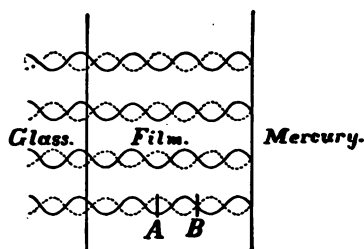

FIG. 86. Principle of Lippman Photograph.

in Fig. 86, where the solid line represents the incident wave and the dotted line the reflected wave. If a particle of silver bromide happens to lie at the point *A*, it will receive energy from the light-wave in the usual way, and may be de-

veloped in the customary manner into a grain of metallic silver. A particle at *B*, however, where there is no liberation of energy from the wave-track, will be entirely unaffected, *i.e.*, unexposed, and thus no deposit will be developed there. Precisely similar effects take place at other points along and through the film, with the result that by development a series of layers is formed, each consisting of particles of metallic silver, and separated from its neighbors by a distance equal to half the wave-length of the light causing the deposit. Since the wave-length of red light is roughly $\frac{1}{37000}$ of an inch, and that of blue light $\frac{1}{80000}$ of an inch, there is thickness enough in even the thinnest film for many such layers, the distance between them varying with the wave-length of the light, and each color establishing an interference system of its own. Professor Lippmann has

shown on theoretical grounds that several such systems may coexist, and that therefore a given part of the film may be affected by several colors at the same time. The actual existence of these layers has been shown by photomicrographs of sections of the film.

When a beam of white light falls upon such a system of reflecting layers, each partially transparent, every layer will reflect a part of the light falling upon it. If the layers are $\frac{1}{4000}$ of an inch apart, the red rays reflected from successive layers will differ in phase by a whole wave-length (half a wave-length going and coming), and will therefore reënforce each other, while the other colors will not; hence the reflected beam appears red. The same reasoning applies to layers differently spaced, and the result is that when such a plate is viewed by reflected light at the proper angle it shows the colors of the original object, while by transmitted light it appears without marked color other than that of the ordinary negative.

For details the reader must be referred to special treatises,¹ but the general principles are as follows:

The first requirement is a special emulsion. It must be transparent, as the light must pass twice through it, and very fine-grained, because of the extremely short distance between the positions of maximum and minimum wave-disturbance. Any such coarseness as that of Figs. 59 and 60 would be out of the question. It may be remarked that the preparation of such an emulsion was one of the greatest difficulties in the development of the process. The coated plate, bathed with suitable dyes to make it sensitive to all parts of the

¹ VIDAL, "Traité Pratique de Photochromie." BAYLEY, "Natural Color Photography."

visible spectrum, is put into a special plate-holder, glass side outward, and the reflecting surface obtained by pouring mercury into the space behind the plate, thus bringing the mercury into contact with the film. Exposure and development are made in the customary way, but the time of fixing must be as short as possible consistent with completeness, as the fixing bath exerts a noticeable solvent action on the very fine silver particles of the image. When intensified, dried, and held in a beam of light at the proper angle, the plate reflects the colors of the object.

Lippmann photographs are obtainable commercially through dealers in physical and optical apparatus, but at prices which suggest that their production is difficult on an extended scale, and the percentage of failures large. They are not for the worker of ordinary skill to attempt.

Indirect Processes. — The situation here is less discouraging to the experimenter of modest powers, for the manipulations are the familiar ones, and little special apparatus is required. Indirect processes depend on getting what may be called color records of the object, and then suitably coloring these monochromatic records afterwards. The principle of color records may be illustrated as follows:

Suppose a red-and-green object is photographed through a red screen in front of the lens. The negative is, of course, black and white, but it represents the distribution of red light over the object, and if a positive is made and illuminated by red light the result will be a reproduction of the red radiation from the object. Similarly, a negative made behind a green screen, and a corresponding positive illuminated by green light, will reproduce the green radiation from the object. Now if an optical system of any kind is employed, by which

these color impressions can be superposed and conveyed simultaneously to the eye, the compound color sensation will be similar to that given by the object itself.

Ives Process. — Work along the above line is not new, but its perfecting has only in recent years been accomplished, largely through the work of Mr. F. E. Ives. It is an adaptation of the accepted theory of color vision, first propounded by Young and worked out quantitatively by Helmholtz and Maxwell. Three negatives are taken, behind red, green, and violet screens respectively, the colors required by the theory being modified only so far as required by the limitations of existing plates and dyes. These exposures are developed in the usual way, and a lantern-slide positive made from each. Following the argument of the preceding paragraph, if red, green, and violet glasses are placed in front of the corresponding positives, the result will represent the distribution of the original radiation from the object; and if the three images can be superposed, the eye will receive a composite illumination; and both theory and experiment unite in testifying that the resulting color sensation is a faithful counterpart of the original object, if the screens and plates have been properly chosen. In the lecture room the superposition is accomplished by a triple projection lantern; for the home by a form of viewing camera or stereoscope called a *Kromskop*, in which an ingenious arrangement of mirrors serves to unite the three images.

When the three images are accurately superposed and the colors of the screens correctly adapted to the plates, the results are more perfect in truthfulness of color than those obtained by any other method; and it is much to be regretted that the necessary complication of the apparatus and

the requirement of accurate workmanship make it rather costly.

Joly and McDonough Processes. — The superposition of the three images has been accomplished in a simpler and ingenious though less perfect way, by Dr. John Joly in Dublin and Mr. James McDonough in Chicago. If a screen is made by ruling a transparent surface with successive sets of narrow red, green, and violet bands, and a plate exposed under it, it is plain that under each band there will be formed the corresponding color record, and a positive from this negative will likewise be made up of strips of the three color records. If now there is placed in contact with the positive a similarly ruled screen, whose color bands are placed exactly in the positions of the screen colors used in making the negative, each strip of the positive will be appropriately colored and the whole image will appear as if made up of successive strips of each of the three colored positives of the Ives process. When viewed directly, or projected with the lantern so that the visual angle subtended by one set of lines does not exceed one minute, the striping is barely noticeable.

Evenly ruled screens are somewhat difficult to produce, and their adaptation to the color sensitiveness of the plate must be very close to insure good results. The camera requires a little fitting to adapt the taking screen to it, so that it may be brought into contact with the plate for the exposure and removed when the plateholder slide is to be reinserted. But the manipulations are simple, and excellent results are obtainable in practice.

The Joly screens contain eighty sets of lines to the inch, each line therefore being $\frac{1}{80}$ inch in width. The McDonough screens contain one hundred sets per inch, and are of slightly

different colors, which may be in part necessitated by the different plates used for making the negatives. The lines are ruled upon gelatine-coated glass plates with aniline inks. It is to be regretted that these methods have not proved commercially successful.

Starch-Grain Process. — A still further modification, of perhaps even greater ingenuity, is due to the Messrs. Lumière of Lyons, and is said to be nearly ready for the market. Finely divided starch, having forty or fifty grains to the millimeter, is colored red, green, and violet in separate portions, and the powders mixed until the mixture shows no color. It is then spread over a slightly sticky surface so that the grains lie as close together as possible, but in a layer only one grain deep. The spaces between the grains are then filled with a black pigment, such as charcoal ground to an impalpable fineness, and the whole covered with an impermeable varnish. The silver emulsion is coated upon this, and the result is a combined plate and three-color screen, to be exposed in the camera, glass side outwards. If this were developed and fixed in the ordinary way, the colors showing by transmitted light would be complementary to those producing the image, since the silver deposit produced by development is opaque. It is therefore necessary to dissolve out the deposit of metallic silver, after development and before fixing, after which the remainder of the silver in the film is developed and fixed as usual. The colors then show properly by transmitted light.

Absorption Processes. — Simplest of all the methods in use, and entirely within the province of the ordinary worker, are those in which the three color records are directly superposed, and the colors obtained by absorption. But a new set of colors is now needed. In the Ives process, for example, the

three positives cannot be superposed to produce the picture, for the red glass absorbs all but the red, the green glass all but the green, and the violet correspondingly all but the violet; so that if the colors were pure, the superposition of the three glasses, or any two of them, would produce simply darkness. It is possible, however, to superpose a set of three suitably colored positives so as to reproduce the colors of the original, as may be shown with the help of Fig. 87.

Suppose the object (*a*) to be a green plant with a red flower, in a blue or violet-colored pot, these colors being chosen merely for simplicity of explanation. Let the pot stand on a white support, against a black background. Then a set of three negatives, taken behind red, green, and violet screens respectively, will appear as in (*b*). Next let a positive on glass be made from each negative, as in the carbon process, but in uncolored clear gelatine, and let the positive from the "red" negative be stained with a dye which absorbs the red sensation of the spectrum and nothing else. Such color is said to be complementary to red, and is a bright greenish blue. The positive from the "green" negative is to be stained with a green-absorbing dye, which is a purplish red; and the third positive is to be stained with a violet-absorbing dye, which is yellow.

In the actual case, only one positive is made on glass, the other two being upon thin celluloid, so as to bring the three image films as closely together as possible.

If these three positives are superposed and examined by transmitted light, only that color will be seen which has passed through all three films. The separate positives are shown in (*c*). The red-absorbing positive will be clear in the portions which were red in the original object, and will absorb

red elsewhere. The green-absorbing positive will be clear in the regions corresponding to the green portions of the object,

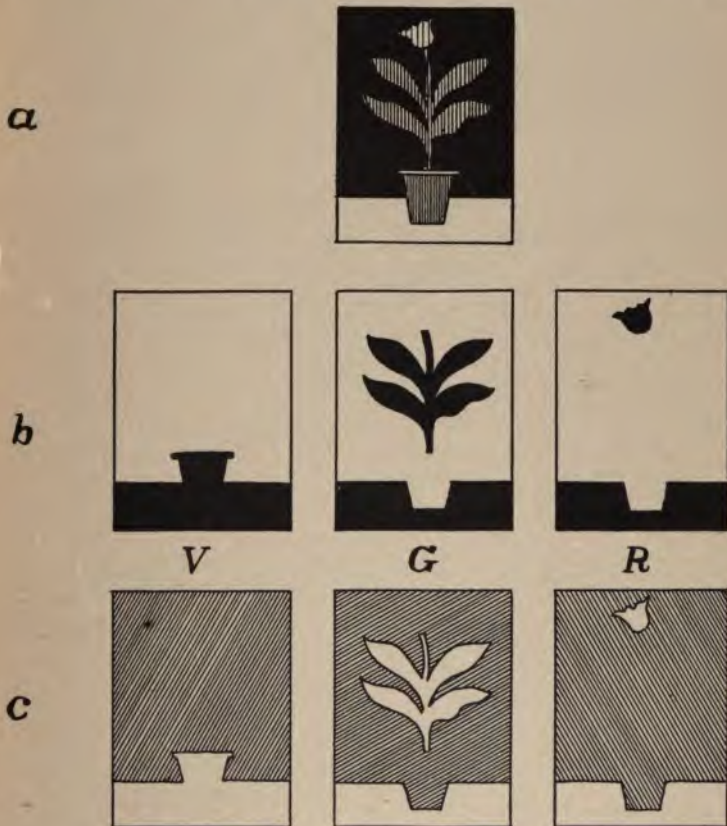

FIG. 87. Absorption Process of Color Photography.

but will absorb green elsewhere; and corresponding conditions apply to the violet-absorbing positive. On examining the absorption in detail, beginning with the red flower, it will

be seen that the white light passing unobstructed through this portion of the red-absorbing positive will lose its green component in traversing the green-absorbing film and its violet component in traversing the violet-absorbing film, finally emerging as red, since only the red is unabsorbed. The red-absorbing positive cuts the red out of the light falling upon the image of the leaves, the violet-absorbing positive cuts out the violet, while the green-absorbing positive is transparent in the leaf portion; hence the green is the only color unabsorbed, and the leaves therefore appear green. By similar analysis it can be shown that every color, even the compound ones, can be reproduced, with a faithfulness that depends only on the dyes employed.

The materials and instructions for the above process are obtainable through supply houses, under various trade names. The work is fascinating in a high degree, and not as difficult as might be supposed, though really first-class pictures are by no means easy to secure. The pictures must be viewed by transmitted light or projected with the lantern. Methods of fixing the gelatine positives upon paper are attended with difficulties of manipulation, and are usually far from giving the satisfaction obtainable with the transparent positives.

Three-color Printing. — The principle here outlined is the basis of the "three-color" process used for producing color prints by the printing-press. The original object or scene is photographed with the three screens as before, and a printing-block made from each of the three negatives. Printing is done with inks of the colors complementary to those used in making the negatives, the three impressions being of course superposed, and the light reflected from the surface of the paper taking the place of the transmitted light in the preceding

description. The printer, however, is seriously handicapped in his choice of colors for the inks to be used, for the requirements of hue, transparency, permanence, and printing qualities form a combination that is difficult in the extreme to secure. This subject, however, is far beyond the scope of a treatise for the student of general photography.

Bleach-out Processes. — These depend on the principle that when work is done by any form of energy the energy producing the effect is necessarily absorbed. Three superposed films are employed, stained with fugitive dyes which are respectively complementary to the primary red, green, and violet, and which may be designated as greenish blue, purple-red, and yellow.

From the principle thus laid down (see also page 107), it follows that the bleaching of the purple-red film will be accomplished by the rays it absorbs, *i.e.*, the green rays. If therefore an ordinary lantern-slide positive is made from a negative taken by green light, and the positive covered with a green glass in the printing-frame, the transparent portions will transmit green light, which will therefore bleach out the green-absorbing film under them, without affecting the other two, which do not absorb green. Similarly, the yellow dye in the second film will be bleached by the rays it absorbs, *i.e.*, the violet rays. Thus the positive made from the violet negative must be covered with a glass of similar color. In like manner, the positive made from the red negative must be covered with a red glass; but in practice an orange glass is used because of the low sensitiveness of the dye to pure red light. Action on all three films, of course, results in complete bleaching and consequently no color appears, the films showing white; while partial bleaching of either or

all the films gives all the colors obtainable by superposition of such dyes.

The relation between the various colors employed and their action upon the dyes may perhaps be made clearer by the following table:

TABLE IX. COLOR SCHEME OF THE BLEACH-OUT PROCESS.

NEGATIVES.	FILM DYES.	COLOR OF SCREEN IN PRINTING FRAME.	DYE BLEACHED.
R	Red-absorbing = greenish blue.	Red or Orange.	Red-absorbing.
G	Green-absorbing = purplish red.	Green.	Green-absorbing.
V	Violet-absorbing = yellow.	Violet or blue.	Violet-absorbing.

This method requires not only selectively fugitive dyes, but dyes which can be fixed after any degree of bleaching; and although fairly satisfactory results have been obtained, the process is still in the experimental stage. In the Szczepanik process the fixing is accomplished by soaking the films in benzole for some hours after printing. Improvements in the sensitiveness of the dyes have been made, indicating a possibility of making colored positives directly in the camera, by simply making successive exposures behind the red, green, and violet screens.

Wood Diffraction Process.¹ — If a sheet of glass or other transparent substance is ruled with a series of closely spaced equidistant parallel lines and placed before a lens illuminated from a small bright point or line parallel to the rulings, there will be produced, on each side of the principal image of the

¹ Wood, *Nature*, June 29, 1899.

point, a spectrum with its violet end nearest the image. This effect is caused by diffraction at the edges of the lines, and the ruled surface is called a diffraction grating. On a receiving screen the spectrum takes the position indicated in Fig. 88, and if a hole is made in the screen, an observer behind it will see the lens filled with light of whatever color of the spectrum falls upon the hole. A grating with more closely spaced rulings will give a similar spectrum, but at a greater distance from the central image, the displacement increasing with the fineness of the rulings. Suppose, for example, that a

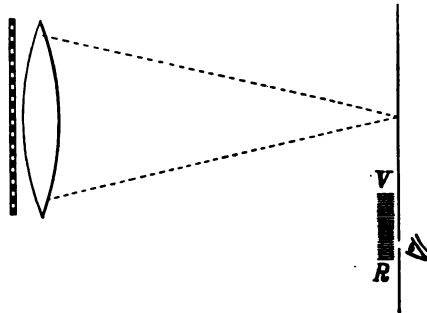

FIG. 88. Spectrum through Lens and Diffraction Grating.

grating with 2000 lines to the inch is used, and that the hole in the screen is made in the red, so that the eye behind the hole sees the lens filled with red light. If a grating with 2400 lines per inch is substituted for the other, the increased displacement brings the green opposite the hole, and the observer will see the lens filled with green light. Similarly, a grating with 2750 lines per inch will throw the violet portion of the spectrum on the hole.

This principle has been applied to color photography by Professor R. W. Wood in the following way: It is clear from the preceding that if a transparent positive is ruled as described, the portions covered by the different rulings will appear of the corresponding colors when viewed in the manner

described. For example, if the flower in Fig. 87 is ruled with 2000 lines to the inch, the leaves with 2400, and the pot with 2750, the stand with all three sets, and the background left without rulings, the observer behind the hole will see a red flower with green leaves in a blue pot, on a white stand with a dark background. The photographic problem is therefore to obtain transparent images containing the appropriate rulings. This is solved by making the usual three negatives behind red, green, and violet screens, and a lantern positive from each. A sheet of glass, coated with transparent bichromated gelatine, is then placed in contact with a 2000-line screen the full size of the image, the positive from the "red" negative is placed over them, and the whole exposed to light. As in the carbon process, the gelatine becomes insoluble under the clear portions of the red-printing positive, the line structure of the grating printing itself also over all the exposed portions. The red-printing positive and grating are then removed, and the green-printing positive and a 2400-line screen substituted. The green-printing positive produces its impression upon the gelatine through the 2400-line screen, and thus a different ruling is photographed upon the portions of the image corresponding to the green of the object. A similar process is required for the violet. Proper register of the three positives is secured by suitable reference marks on the plates.

Development is accomplished by placing the film for a few minutes in warm water, after which rinsing and drying complete the process. Though there is no theoretical objection to the making of all three impressions on a single film, in practice it is found better to put the red and green printings on one plate and the violet on another, placing the two in contact and binding them together for viewing. It is possible to project

the pictures, but with some difficulty; they are best viewed individually.

Accurate work depending upon the interference of light demands very perfect workmanship of the optical portion of the apparatus, and in this process the results evidently depend on the accuracy of the gratings used. This is difficult to secure without considerable expense. One advantage, however, of the Wood process goes far to offset the original difficulty. Once having obtained a good picture, it can be copied directly and an indefinite number of times, for the print of a diffraction grating is just as effective as the original itself, the terms "positive" and "negative" losing their significance altogether in this case.

www.libtool.com.cn

•

•

•

INDEX

- Aberration :
chromatic, 26, 30.
of simple lens, 31.
correction of, 34, 37.
spherical, 26.
controllable, 27.
correction of, 27.
test for, 28.
zonal, 29.
- Aberrations, the five, 49.
- Achromatism, 32.
- Actinometer, 186.
- Action of sensitizing dyes, 106.
- Allowable displacement of image, 211.
- Angle of view, 88.
- Astigmatism, 26, 38.
correction for, 40.
- Axis of a lens, 9.
- Blue line prints, 179.
- Blue-print process, 122, 177.
- Brightness, of pin-hole image, 8.
of lens image, 80.
- Camera, 90.
panoramic, 18.
tests, 90.
- Carbon process, 122, 183.
double transfer, 187.
single transfer, 189.
- Characteristic curves, 128.
- Circle of confusion, 4, 76.
- Cleaning spoiled plates, 196.
- Clearing bath, 195.
- Collinear relation, 41.
- Color of image, 122.
- Color photography :
absorption processes, 235.
- Color photography (*continued*) :
bleach-out processes, 239.
Ives process, 233.
Joly and McDonough processes, 234.
Lippmann process, 230.
starch-grain process, 235.
Wood diffraction process, 240.
- Color screens, 102, 106.
- Color sensitiveness of silver salts, 99.
- Color-sensitizing baths, 102.
- Coma, 26, 29.
- Combination lenses, 56, 57.
- Condenser, 207.
- Copying, rule for, 14.
- Copying camera, 197.
- Crown glass, 33.
- Curvature of field, 26, 37.
correction for, 38.
- Daguerreotype, 120.
- Depth of focus, 77.
- Developer, 109.
- Developers, various :
ferrous oxalate, 136.
hydroquinone, 135.
ortol, 138.
time, 138.
- Development, 119.
methods of, 120.
- Diaphragm, 76.
best position of, 55.
iris, 84.
measurement of effective diameter,
85.
rotating, 83.
systems of marking, 82.
use of star shape, 54.
- Diffraction, 6, 240.

- Dispersion, 33.
 irrationality of, 34.
 Distortion, 26, 41.
 correction for, 42.
 Dry plates :
 development of, 121, 123.
 making, 110.
 Efficiency of shutters, 225.
 Electric arc light, 205.
 Emanations, effect of, 142.
 Enlarged negatives, 203.
 Equivalent planes, 10.
 Exposure meters, 133.
 Exposure tables for moving objects, 213, 216.
 Factorial development, 132.
 Finder, 92.
 Fixing bath formula, 146.
 Flare, 26, 43.
 in various lenses, 46.
 test for, 45.
 Flint glass, 33.
 Focal length, 12.
 measurement of, 15.
 of a lens system, 19.
 suitable values of, 89.
 Focal points, 11.
 Focal planes, 11.
 Focal-plane shutter, 223.
 Focus :
 back, 18.
 equivalent, 19.
 Focusing arrangements of camera, 91.
 Focusing cloth, 95.
 Fog, 124.
 Formaldehyde as hardener, 148, 150.
 Fraunhofer lines :
 as reference marks, 32.
 colors of, 33.
 Ghosts, 47.
 Gum process, 122.
 Halation, 170.
 Hand camera, 93.
 Hyperfocal distance, 78.
 Hypo, 145.
 solubility of, 147.
 test for, 149.
 Image :
 formula for destroying, 169.
 geometrical construction of, 12, 13.
 Instantaneous photographs, 210.
 Intensification, 152.
 enlargement of particles in, 156.
 with ammonia, 155.
 with redevelopment, 154.
 with sodium sulphite, 154.
 with uranium, 158.
 Ionization hypothesis, 117.
 Kits, 96.
 Lantern slides, 190.
 by contact, 191.
 by copying, 199.
 from drawings, 201.
 mounting, 196.
 use of reducer on, 194.
 Latent image, 114.
 Latitude of exposure, 130.
 Lens testing, 72.
 Lenses :
 air, 60.
 aplanatic, 28.
 apochromatic, 35.
 care of, 74.
 cemented, 49.
 color correction of, 37.
 convertible, 20.
 deterioration of, 75.
 faults of, 26.
 focusing, 92.
 formula for, 13.
 function of, 24.
 projecting, 208.
 rectilinear, 42.
 simple, 36.
 single, 55.
 symmetrical, 22.
 telephotographic, 63.
 wide-angle, 53, 89.
 Lenses, various :
 Bausch & Lomb — Zeiss, 21.
 Goerz, double anastigmat, 23, 58.
 hypergon, 54.
 Ross, homocentric, 59.
 Steinheil, orthostigmat, 53.
 unofocal, 61.

- Lenses, various (*continued*):
 Taylor, *Taylor & Hobson*—*Cooke*,
 59, 92.
 Voigtländer, apochromatic, 35.
 collinear, 22.
 dynar, 60.
 heliar, 60.
 Zeiss, planar, 58.
 telephotographic, 64.
 tessar, 59.
- Level, 95.
 Light filters, 102.
 Light for dark room, 107.
 Light ray, 24.
 Lime light, 205.
- Magnifier, 95.
 Molecular strain hypothesis, 117.
- Nodal points, 10.
 in symmetrical lenses, 23.
 in telephotographic lenses, 66.
 method of finding, 17.
 position of, 11.
- Non-halation plates, 173.
- Optical interval, 19.
 Orthochromatic plates, 105.
- Permanence of silver image, 159.
 Perspective of lenses, 86.
 Petzval condition, 61.
 Photo-chemical action, 109.
 Photograph, limitations of, 3.
 Pin-holes, 4.
 best diameter of, 7.
 method of making, 7.
 Plate-holders, 96.
 Plate markings, 140.
 Platinum prints, 182.
 Potassium bromide as restrainer, 128.
 Printing processes, 176.
- Projection lantern, 204.
- Reducers, 166.
 Reduction:
 by alcohol, 168.
 by ammonium persulphate, 165.
 by Farmer solution, 163.
 by ferric chloride, 164.
 Reduction product, quantity of, 112.
 Retardation, 6, 25.
 Reversal, 174.
 Reversible back, 94.
- Screen for lantern pictures, 209.
 Shutter speed measurement:
 by falling body, 218.
 by pendulum, 217.
 by revolving wheel, 217.
- Silver prints, 180.
 Silver-grain hypothesis, 114.
 Spectrum, secondary, 35.
 Sub-haloid hypothesis, 115.
 Swing backs, 93.
- Telephotographic lens, 65, 69.
 construction of, 63.
 formulæ for, 67.
 Telephotographic negative lens, 70.
 Test objects, 72.
 Three-color photography, 232.
 lenses for, 36.
 Three-color printing, 238.
 Time development, 133.
 Toning, 181.
 Tripod, 94.
- Ultra-violet light, 101.
 Unequal illumination, 26, 50.
 Universal focus, 78.
- Washing, 148.
 Wet-plate process, 121.

www.libtool.com.cn

1
2
3

The Geography of Commerce

By **SPENCER TROTTER, M.D.**

*Professor of Biology and Geology in Swarthmore College,
Pennsylvania*

This book is the first volume of **Macmillan's Commercial Series**, of which it, together with three other volumes, forms the backbone. The book is exceptionally fortunate as well as unique in its **authorship**. Dr. Trotter is a scientist and geographer of high standing, while the editor, Dr. Merrick, who was associated with him in the preparation and revision of the manuscript, is a trained economist. Both are experienced and successful teachers. Moreover, the text has been studied by high school students, and the matter so altered as to bring it fairly within their comprehension.

The Geography of Commerce gives a clear presentation of the existing conditions of trade. Throughout the book emphasis is laid on the **relation between physiography and the activities and the organizations of men**. In dealing with other countries their trade relations with the United States are given special prominence. In considering the causal relations of physical environment to men, of men and environment to products, and of products to trade, there is given a unity that makes the book **readily adapted for class use**.

Dr. Trotter's book is on the "**practical side**" of **geography**, which, according to a recent statement of a recognized authority, "is best taught in a well-developed course of commercial geography placed after earlier courses on general geography in the grades and a course in elementary physiography either in the grades or in an early high school year."

The book is furnished with a **working equipment** which is as complete as possible. The subject is new, and it has been thought wise to append lists of books for further consultation. These lists are meant merely as suggestions as to some of the available newer material. Supplementary questions and topics are also supplied.

The Macmillan Company

New York

Boston

Chicago

San Francisco

Atlanta

THE HISTORY OF AMERICAN ART

Edited by JOHN C. VAN DYKE

www.libtool.com.cn

The History of American Music

By LOUIS C. ELSON

Author of "OUR NATIONAL MUSIC"

Musical Editor of the *Boston Advertiser*

W

Fully illustrated with twelve photogravure plates
and over one hundred illustrations in the text

Cloth

Imperial 8vo

\$5.00 net

The work, the first in its field, takes up every phase of its subject, beginning with Indian music, Folk music, and the Psalmody of the Pilgrims and Puritans, and carrying the topic down to 1903.

"This is preëminently a history for the general reader, with narrative and critical features nicely balanced. . . . It fills a void in our national literature that has long been apparent."—*North American*, Philadelphia.

THE MACMILLAN COMPANY

64-66 FIFTH AVENUE, NEW YORK

THE HISTORY OF AMERICAN ART

Edited by JOHN C. VAN DYKE

www.libtool.com.cn

The History of American Painting

By **SAMUEL ISHAM**

ASSOCIATE OF THE NATIONAL ACADEMY OF DESIGN

MEMBER OF THE SOCIETY OF AMERICAN ARTISTS

With twelve full-page photogravures and one
hundred and twenty-one illustrations in the text

Cloth

Octavo

\$5.00 net

The author traces the development of art in this country, showing the external influences that were brought to bear, and how they were developed by the social conditions of America and the personality of the artists.

THE MACMILLAN COMPANY

64-66 FIFTH AVENUE, NEW YORK

THE HISTORY OF AMERICAN ART

Edited by JOHN C. VAN DYKE

www.libtool.com.cn

The History of American Sculpture

By LORADO TAFT

MEMBER OF THE NATIONAL SCULPTURE SOCIETY

With twelve full-page plates in photogravure and
over one hundred half-tone illustrations in the text

Cloth

Imperial 8vo

\$6.00 net

“For the fulness of its history, the soundness of its judgments, and the profuseness and excellence of its illustrations, Lorado Taft’s ‘History of American Sculpture’ is a volume to be prized by all who are in any way interested in American art.”

— *Plain Dealer*, Cleveland.

“If the other volumes of the series prove as generally satisfactory as Mr. Taft’s ‘History of American Sculpture,’ we shall have a monumental and indispensable survey of the whole achievement of American art.” — *New York Evening Post*.

THE MACMILLAN COMPANY

64-66 FIFTH AVENUE, NEW YORK

www.libtool.com.cn

LANE MEDICAL LIBRARY

To avoid fine, this book should be returned on
or before the date last stamped below.

FEB - 1 1946

www.libtool.com.cn